

MELSEC FX Series

Programmable Logic Controllers

Operation Manual



FX Configurator-FP

Safety Precautions

(Read these precautions before using.)

Before installing, operating, maintenance or inspecting this product, thoroughly read and understand this manual and the associated manuals. Also pay careful attention to handle the module properly and safety.

This manual classifies the safety precautions into two categories: **⚠ DANGER** and **⚠ CAUTION**.

 DANGER	Indicates that incorrect handling may cause hazardous conditions, resulting in death or severe injury.
 CAUTION	Indicates that incorrect handling may cause hazardous conditions, resulting in medium or slight personal injury or physical damage.

Depending on circumstances, procedures indicated by **⚠ CAUTION** may also be linked to serious results.

In any case, it is important to follow the directions for usage.

Store this manual in a safe place so that you can take it out and read it whenever necessary. Always forward it to the end user.

1. DESIGN PRECAUTIONS



 DANGER	Reference
<ul style="list-style-type: none"> • Provide a safety circuit on the outside of the PLC so that the whole system operates to ensure the safety even when external power supply trouble or PLC failure occurs. Otherwise, malfunctions or output failures may result in an accident. <ol style="list-style-type: none"> 1) An emergency stop circuit, a protection circuit, an interlock circuit for opposite movements, such as normal and reverse rotations, and an interlock circuit for preventing damage to the machine at the upper and lower positioning limits should be configured on the outside of the PLC. 2) When the PLC CPU detects an error, such as a watch dog timer error, during self-diagnosis, all outputs are turned off. When an error that cannot be detected by the PLC CPU occurs in an input/output control block, output control may be disabled. Design external circuits and mechanisms to ensure safe operations of the machine in such a case. 3) When some sort of error occurs in a relay, triac or transistor of the output unit, output may be kept on or off. For output signals that may lead to serious accidents, design external circuits and mechanisms to ensure safe operations of the machine in such cases. 	59

 CAUTION	Reference
<ul style="list-style-type: none"> • Observe the following items. Failure to do so may cause incorrect data-writing by noise to PLCs and result the PLC failure, machine damage or an accident. <ol style="list-style-type: none"> 1) Do not lay close or bundle with the main circuit line, high-voltage line, or load line. Noise and Surge induction interfere with the system operation. Keep a safe distance of least 100 mm (3.94") from the above lines during wiring. 2) Ground the shield wire or shield of a shielded cable at one point on the PLC. However, do not ground at the same point as high voltage lines. • Install in a manner which prevents excessive force from being applied to the built-in connectors dedicated to programming, power connectors and I/O connectors. Failure to do so may result in wire breakage or failure of the PLC. 	59



Safety Precautions

(Read these precautions before using.)

2. INSTALLATION PRECAUTIONS

 DANGER	Reference
<ul style="list-style-type: none"> • Make sure to cut off all phases of the power supply externally before starting the installation or wiring work. Failure to do so may cause electric shock. 	59
 CAUTION	Reference
<ul style="list-style-type: none"> • Fit the extension cables, peripheral device connecting cables, input/output cables and battery connecting cable securely to the designated connectors. Contact failures may cause malfunctions. • Make sure to attach the terminal cover offered as an accessory to the product before turning on the power or starting the operation after installation or wiring work. Failure to do so may cause electric shock. 	59

3. STARTUP AND MAINTENANCE PRECAUTIONS

 DANGER	Reference
<ul style="list-style-type: none"> • Do not touch any terminal while the PLC's power is on. Doing so may cause electrical shock or malfunctions. • Before cleaning or retightening terminals, externally cut off all phases of the power supply. Failure to do so may expose you to shock hazard. • Before modifying the program under operation or performing operation for forcible output, running or stopping, carefully read the manual, and sufficiently ensure the safety. An operation error may damage the machine or cause accidents. • To test Zero-return, JOG operation and Positioning data, thoroughly read this manual, ensure the safe system operation An operation error may damage the machine or cause accidents. The response, such as the JOG operation, may be slow according to the running state of the personal computer at the time of the test operation. In the test operation, the PLC performance can be slower due to the busy state of personal computer. <ul style="list-style-type: none"> - End all other applications running except FX Configurator-FP. - At destination specification (refer to chapter 6), set the transmission speed at 38.4kbps or higher. 	60
 CAUTION	Reference
<ul style="list-style-type: none"> • Do not disassemble or modify the PLC. Doing so may cause failures, malfunctions or fire. For repair, contact your local Mitsubishi Electric distributor. • Before connecting or disconnecting any extension cable, turn off power. Failure to do so may cause unit failure or malfunctions. • Before attaching or detaching the following devices, turn off power. Failure to do so may cause device failure or malfunctions. <ul style="list-style-type: none"> - Peripheral devices, expansion boards and special adapters - I/O extension blocks/units and terminal blocks 	60

FX Configurator-FP

Operation Manual

Manual number	JY997D21801
Manual revision	D
Date	1/2008

Foreword

This manual describes FX Configurator-FP Setting/Monitoring Tool and should be read and understood before attempting installation or operation of software.

Store this manual in a safe place so that you can take it out and read it whenever necessary. Always forward it to the end user.

This manual confers no industrial property rights or any rights of any other kind, nor does it confer any patent licenses. Mitsubishi Electric Corporation cannot be held responsible for any problems involving industrial property rights which may occur as a result of using the contents noted in this manual.

Outline Precautions

- This manual provides information for the use of the FX Configurator-FP. The manual has been written to be used by trained and competent personnel. The definition of such a person or persons is as follows;
 - 1) Any engineer who is responsible for the planning, design and construction of automatic equipment using the product associated with this manual should be of a competent nature, trained and qualified to the local and national standards required to fulfill that role. These engineers should be fully aware of all aspects of safety with regards to automated equipment.
 - 2) Any commissioning or service engineer must be of a competent nature, trained and qualified to the local and national standards required to fulfill that job. These engineers should also be trained in the use and maintenance of the completed product. This includes being completely familiar with all associated documentation for the said product. All maintenance should be carried out in accordance with established safety practices.
 - 3) All operators of the completed equipment should be trained to use that product in a safe and coordinated manner in compliance to established safety practices. The operators should also be familiar with documentation which is connected with the actual operation of the completed equipment.

Note: the term 'completed equipment' refers to a third party constructed device which contains or uses the product associated with this manual

- This product has been manufactured as a general-purpose part for general industries, and has not been designed or manufactured to be incorporated in a device or system used in purposes related to human life.
- Before using the product for special purposes such as nuclear power, electric power, aerospace, medicine or passenger movement vehicles, consult with Mitsubishi Electric.
- This product has been manufactured under strict quality control. However when installing the product where major accidents or losses could occur if the product fails, install appropriate backup or failsafe functions in the system.
- When combining this product with other products, please confirm the standard and the code, or regulations with which the user should follow. Moreover, please confirm the compatibility of this product to the system, machine, and apparatus with which a user is using.
- If in doubt at any stage during the installation of the product, always consult a professional electrical engineer who is qualified and trained to the local and national standards. If in doubt about the operation or use, please consult the nearest Mitsubishi Electric distributor.
- Since the examples indicated by this manual, technical bulletin, catalog, etc. are used as a reference, please use it after confirming the function and safety of the equipment and system. Mitsubishi Electric will accept no responsibility for actual use of the product based on these illustrative examples.
- This manual content, specification etc. may be changed without a notice for improvement.
- The information in this manual has been carefully checked and is believed to be accurate; however, if you have noticed a doubtful point, a doubtful error, etc., please contact the nearest Mitsubishi Electric distributor.

Registration

- Microsoft® and Windows® are either registered trademarks or trademarks of Microsoft Corporation in the United States and/or other countries.
- The company name and the product name to be described in this manual are the registered trademarks or trademarks of each company.

Table of Contents

SAFETY PRECAUTIONS	(i)
Functions and Use of This Manual	6
Associated Manuals	7
Generic Names and Abbreviations Used in Manuals	8
Reading of the Manual	10
Included items	11

1. Introduction

1.1 Product Outline	12
1.2 Function List	12
1.3 System Configuration	13
1.3.1 System Configuration	13
1.3.2 Applicable models	16
1.3.3 Operating System Requirements	16

2. Installation, Uninstallation, Startup and Exit

2.1 Installation	17
2.2 Uninstallation	17
2.3 Starting FX Configurator-FP	18
2.3.1 Starting FX Configurator-FP from the start menu	18
2.3.2 Starting FX-Configurator-FP from the tool menu in GX Developer	19
2.4 Closing FX Configurator-FP	20

3. Window configuration and basic operation

3.1 Window configuration	21
3.2 Menu configuration	21
3.3 Tool menus and tool button list	23
3.4 Shortcut key list	24
3.5 Basic operation	24
3.5.1 Basic operations in the file data list	24
3.5.2 Basic operations in dialog box	25
3.6 Help	25

4. Creating files

4.1 Creating a new file	27
4.1.1 Creating a new file	27
4.1.2 Creating a new file with the data inside 20SSC-H	28
4.2 Opening a stored file	29
4.3 File storage	31
4.3.1 Saving files	31
4.3.2 Saving as files	32
4.4 Closing files	33

5. Data set	34
5.1 User unit and Converted pulse data.....	34
5.1.1 User unit	34
5.1.2 Converted pulse data	34
5.1.3 Rotation and operation speed of servo motor (Converted pulse data).....	34
5.2 Setting positioning parameters.....	35
5.3 Setting servo parameters	40
5.4 Setting table information	42
5.4.1 The common items in table information.....	42
5.4.2 Setting X/Y-axis table information	43
5.4.3 Setting XY-axis table information	44
5.5 Error check.....	45
6. Setting the connection destination	46
7. Read / Write / Verify / Initialize	48
7.1 Data type and storage location	48
7.2 Reading [positioning/servo parameters and table information].....	51
7.3 Writing [positioning/servo parameters and table information]	52
7.3.1 Writing to the BFM.....	52
7.3.2 Writing to the Flash ROM	53
7.4 Verifying [positioning parameters, servo parameters table information]	54
7.5 Initializing the BFM and Flash ROM.....	56
7.6 Execute system reset of the 20SSC-H.....	57
7.7 Sets the servo parameter update stop	57
7.8 The displayed messages and countermeasures.....	58
8. Debug in the positioning	59
8.1 Monitor	61
8.1.1 Monitoring the operation.....	61
8.1.2 Signal monitor.....	63
8.1.3 Operation status monitor	64
8.1.4 Monitoring table information	67
8.2 Testing the Operation.....	68
8.2.1 Switching into test mode.....	68
8.2.2 Operation test in the positioning (except JOG/MPG)	69
8.2.3 Changing the present value.....	72
8.2.4 Speed change	74
8.2.5 Zero return.....	76
8.2.6 JOG/MPG	78
8.2.7 Turning OFF m codes.....	80
8.2.8 Stopping all axis	80
8.2.9 Error rest.....	80
8.2.10 Servo ON/OFF.....	81
9. Print	82
9.1 Setting the printer.....	82
9.2 Printing	83
9.2.1 Setting the item to print.....	83
9.2.2 Printing examples.....	86

10. Edit function in data setting	87
10.1 Cut / Copy / Paste / Select all	87
10.1.1 Cut/Copy.....	87
10.1.2 Paste	88
10.1.3 Select all.....	89
10.2 Cursor jump.....	89
10.3 Initializing rows/columns	90
10.4 Insert row	90
10.5 Delete row	91
10.6 Initializing data	92
Warranty.....	93
Revised History	94

Functions and Use of This Manual

FX Configurator-FP is the setting/monitor tool for use with a personal computer.
 FX Configurator-FP is a setting/monitor tool for the FX3U-20SSC-H positioning block and the servo amplifier applicable to SSCNETIII can perform the parameter setup, the table information setting, the monitor, and the test.

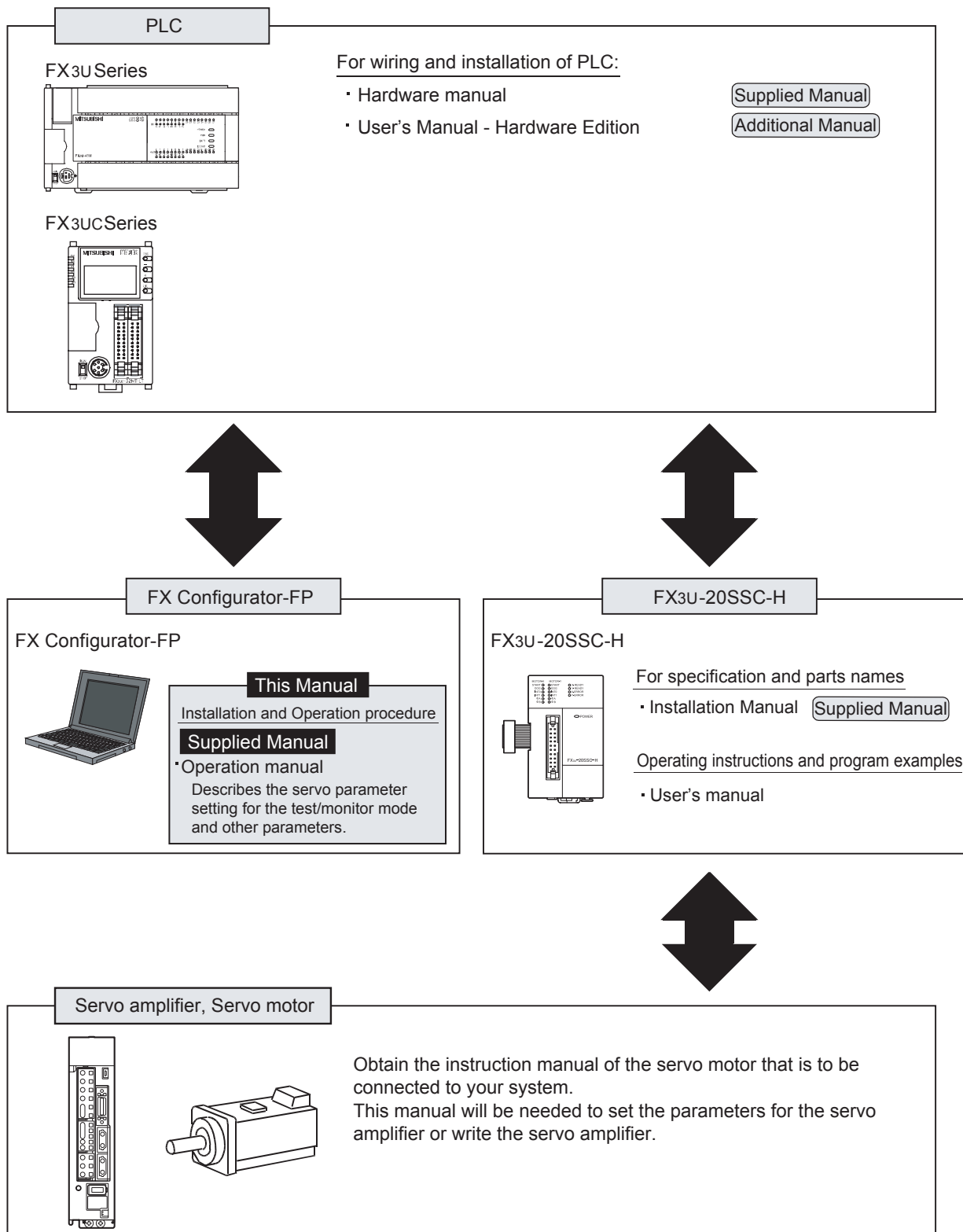

Associated Manuals

For detailed explanation of FX Configurator-FP Configuration Software, refer to this manual.

For the hardware information and instruction on the PLC main unit, other special function unit/block, etc., refer to its respective manual.

For acquiring required manuals, contact the distributor from who you have purchased the product.

⊙ Refer to these manuals

○ Refer to the manual required depending on the equipment used

△ For detail explanation, refer to an additional manual

		Title of manual	Document number	Description	Model code
Manual for the Main Module					
FX3U Series PLCs Main Unit					
△	Supplied Manual	FX3U Series Hardware Manual	JY997D18801	Describes the FX3U Series PLC specifications for I/O, wiring and installation extracted from the FX3U User's Manual - Hardware Edition. For details, refer to FX3U Series User's Manual - Hardware Edition.	-
⊙	Additional Manual	FX3U Series User's Manual - Hardware Edition	JY997D16501	Describes the FX3U Series PLC specifications for I/O, wiring, installation and maintenance.	09R516
FX3UC Series PLCs Main Unit					
△	Supplied Manual	FX3UC Series Hardware Manual (Japanese Only)	JY997D12701	Describes the FX3UC-32MT-LT PLC specifications for I/O, wiring and installation extracted from the FX3UC User's Manual - Hardware Edition. For details, refer to the FX3UC Series User's Manual - Hardware Edition (Japanese Only).	-
△	Supplied Manual	FX3UC (D, DSS) Series Hardware Manual	JY997D28601	Describes the FX3UC-□□MT/D, FX3UC-□□MT/DSS PLC specifications for I/O, wiring and installation extracted from the FX3UC User's Manual - Hardware Edition. For details, refer to the FX3UC Series User's Manual - Hardware Edition.	-
⊙	Additional Manual	FX3UC Series User's Manual - Hardware Edition	JY997D28701	Describes the FX3UC Series PLC specifications for I/O, wiring, installation and maintenance.	09R519
Programming for FX3U/FX3UC Series					
⊙	Additional Manual	FX3U / FX3UC Series Programming Manual - Basic & Applied Instruction Edition	JY997D16601	Describes FX3U / FX3UC Series PLC programming for basic/ applied instructions and devices.	09R517
Manuals for FX3U-20SSC-H Positioning Block					
△	Supplied Manual	FX3U-20SSC-H Installation Manual	JY997D21101	Describes the FX3U-20SSC-H positioning block specifications for I/O, power supply extracted from the FX3U-20SSC-H User's Manual. For details, refer to the FX3U-20SSC-H User's Manual.	-
⊙	Additional Manual	FX3U-20SSC-H User's Manual	JY997D21301	Describes the FX3U-20SSC-H Positioning block specifications.	09R622
⊙	Supplied Manual	FX Configurator-FP Operation Manual	JY997D21801	Describes the FX Configurator-FP Setting/ Monitoring Tool operation details.	09R916

Generic Names and Abbreviations Used in Manuals

Generic name or abbreviation	Description
PLC	
FX3U series	Generic name for FX3U Series PLC
FX3U PLC or main unit	Generic name for FX3U Series PLC main unit
FX3UC series	Generic name for FX3UC Series PLC
FX3UC PLC or main unit	Generic name for FX3UC Series PLC main unit Only manuals in Japanese are available for these products.
Expansion board	
Expansion board	Generic name for expansion board The number of connectable units, however, depends on the type of main unit. To check the number of connectable units, refer to the User's Manual - Hardware Edition of main unit to be used for your system.
Special adapter	
Special adapter	Generic name for high-speed input/output special adapter, communication special adapter, and analog special adapter The number of connectable units, however, depends on the type of main unit. To check the number of connectable units, refer to the User's Manual - Hardware Edition of main unit to be used for your system.
Special function unit/block	
Special function unit/block or Special extension unit	Generic name for special function unit and special function block The number of connectable units, however, depends on the type of main unit. To check the number of connectable units, refer to the User's Manual - Hardware Edition of main unit to be used for your system.
Special function unit	Generic name for special function unit
Special function block	Generic name for special function block The number of connectable units, however, depends on the type of main unit. To check the number of connectable units, refer to the User's Manual - Hardware Edition of main unit to be used for your system.
Positioning special function block or 20SSC-H	Abbreviated name of FX3U-20SSC-H
Optional unit	
Memory cassette	FX3U-FLROM-16, FX3U-FLROM-64, FX3U-FLROM-64L
Battery	FX3U-32BL
FX Series terminal block	FX-16E-TB, FX-32E-TB
Input/output cable or Input cable	FX-16E-500CAB-S, FX-16E-□□□CAB, FX-16E-□□□CAB-R □□□ represents 150, 300, or 500.
Input/output connector	FX2C-I/O-CON, FX2C-I/O-CON-S, FX2C-I/O-CON-SA
Power cable	FX2NC-100MPCB, FX2NC-100BPCB, FX2NC-10BPCB1
Peripheral unit	
Peripheral unit	Generic name for programming software, handy programming panel, and indicator
Programming tool	
Programming tool	Generic name for programming software and handy programming panel
Programming software	Generic name for programming software
GX Developer	Generic name for SW□D5C-GPPW-J/SW□D5C-GPPW-E programming software package
FX-PCS/WIN(-E)	Generic name for FX-PCS/WIN or FX-PCS/WIN-E programming software package
Handy programming panel (HPP)	Generic name for FX-20P(-E) and FX-10P(-E)

Generic name or abbreviation	Description
Setting/Monitoring Tool	
Setting/monitoring tool or FX Configurator-FP	Abbreviated name of FX Configurator-FP Setting/Monitoring Tool
Indicator	
GOT1000 series	Generic name for GT15, GT11 and GT10
GOT-900 series	Generic name for GOT-A900 series and GOT-F900 series
GOT-A900 series	Generic name for GOT-A900 series
GOT-F900 series	Generic name for GOT-F900 series
ET-940 series	Generic name for ET-940 series Only manuals in Japanese are available for these products
Drive unit for servo motor and stepping motor	
Servo motor	Generic name for servo motor or stepping motor Including servo amplifier corresponding to SSCNET III.
Servo amplifier	Generic name for servo amplifier corresponding to SSCNET III
MELSERVO series	Generic name for MELSERVO-J3 series
Other unit	
Manual pulse generator	Generic name for manual pulse generator (prepared by user)
Manual	
FX3u hardware Edition	FX3u Series User's Manual - Hardware Edition
FX3uc hardware Edition	This manual is available only in Japanese.
Programming manual	FX3u/FX3uc Series Programming Manual - Basic and Applied Instructions Edition
Communication control Edition	FX Series User's Manual - Data Communication Edition
Analog control Edition	FX3u/FX3uc Series User's Manual - Analog Control Edition
Positioning control Edition	FX3u/FX3uc Series User's Manual - Positioning Control Edition

Reading of the Manual

Shows the manual title.

This area shows the manual title for the page currently opened.

Shows the title of the chapter and the title of the section.

This area shows the title of the chapter and the title of the section for the page currently opened.

Indexes the chapter number.

The right side of each page indexes the chapter number for the page currently opened.

FX Configurator-FP
Operation Manual

9 Print
9.2 Printing

9.2 Printing

9.2.1 setting the item to print

Printing the positioning parameters, servo parameters and table information.

1 Follow any of the procedures below.

- Click [Print].
- Select [File] → [Print].

The [Print] dialog box appears.

2 Set the item to print.

[Print] dialog box has [Item specification], [Servo parameters] and [table information] tabs. Click the tab to set. For [Servo parameters] and [table information] tabs, refer to the following pages.

1. [Item specification] tab

Item	Description
Axis specification	Specifies the axis data to print
All axis	Prints X, Y and XY-axis data
Axis specification	Prints the ticked axis data <ul style="list-style-type: none"> • X-axis • Y-axis • XY-axis
Print data	Specifies the data type to print
All item	Prints [Positioning parameters], [Servo parameters] and [Table information]
Item specification	Prints the ticked data item <ul style="list-style-type: none"> • Positioning parameters • Servo parameters • Table information
<Printer setting>	Displays [Printer setting] dialog box
<Print>	Outputs to printer depending on the specified contents
<Print preview>	Displays the print preview
<Close>	Closes the dialog box without printing

81

1 Introduction
 2 Initial Setup
 3 Window and Operation
 4 Creating Files
 5 Data set
 6 Setting One Description
 7 Data New Procedure
 8 Changing Data for Printing
 9 Print
 10 Edit Function

1→2→3 . . .
 Indicates the procedure steps. This manual differentiates the menu and items with parentheses
 [] : Refers to the options in the menu bars, dialog box items or FX Configurator-FP utility menu.
 < > : Refers to the dialog box buttons or the PC keyboard.

Shows the reference.
 The mark of " → " is expressing the reference destination and the reference manual.

The above diagram differs from the actual page, as it is provided for explanation only.

Included items

Type (model name)	Product Name	Quantity
FX Configurator-FP (SW1D5C-FXSSC-E)	FX Configurator-FP Version 1(1-license product) (CD-ROM)	1
	Software license agreement	1
	Software registration Card (Japanese document)	1
	FX Configurator- FP Operation Manual (this manual)	1

1. Introduction

1.1 Product Outline

The FX Configurator-FP is a personal computer software for FX3U-20SSC-H and servo amplifiers, applicable to SSCNET III.

- Setting, monitoring and testing the parameters and table information of FX3U-20SSC-H.
- Setting the parameters of servo amplifiers, applicable to SSCNET III.

1.2 Function List

Function		Contents	Reference	
File	New/Open/Save/Print	Reads, saves and prints the contents	Chapter 4, 9	
Edit	Setting positioning parameters in 20SSC-H	Sets the operation parameter, pulse rate, feed rate, MAX/JOG speed	Section 5.1	
	Setting parameters in servo amplifiers	Sets the basic, extension, gain/filter and I/O parameters	Section 5.2	
	Setting table information	Sets the X/Y/XY-axis Table information	Section 5.3	
Online	Read/Write/Verify the module data	Reads, writes and verifies the parameter information in positioning modules	Chapter 7	
Monitor	Monitoring table information	Monitors the present address, status info and servo status	Section 8.1	
	Operation monitor	Operation monitor	Monitors the present address, present speed, axis status of all axis	Section 8.1
		Signal	Monitors the module status and servo status	
		Operation status monitor	Monitors the parameters and operation status of all axis	
Test	Operation test	Positioning starting	Specifies the table number and tests the operation	Section 8.2
		Present value change	Tests the feed present value change	
		Speed change	Tests the speed change	
		OPR	Tests the OPR	
		JOG/MPG Operation	Tests the operation by JOG/MPG	

1.3 System Configuration

1.3.1 System Configuration

The personal computer can be connected to the FX3U-20SSC-H in two ways.

- 1) Direct PLC connection
The personal computer is connected to the PLC main unit directly.
 - 2) Connection via GOT
The personal computer is connected via the GOT's Transparent mode*1 to the PLC main unit.
- *1. Connection via GOT supported by GT15, GT11 of GOT1000 Series only.

1. Direct PLC connection

This subsection shows the system configurations for direct PLC connection.

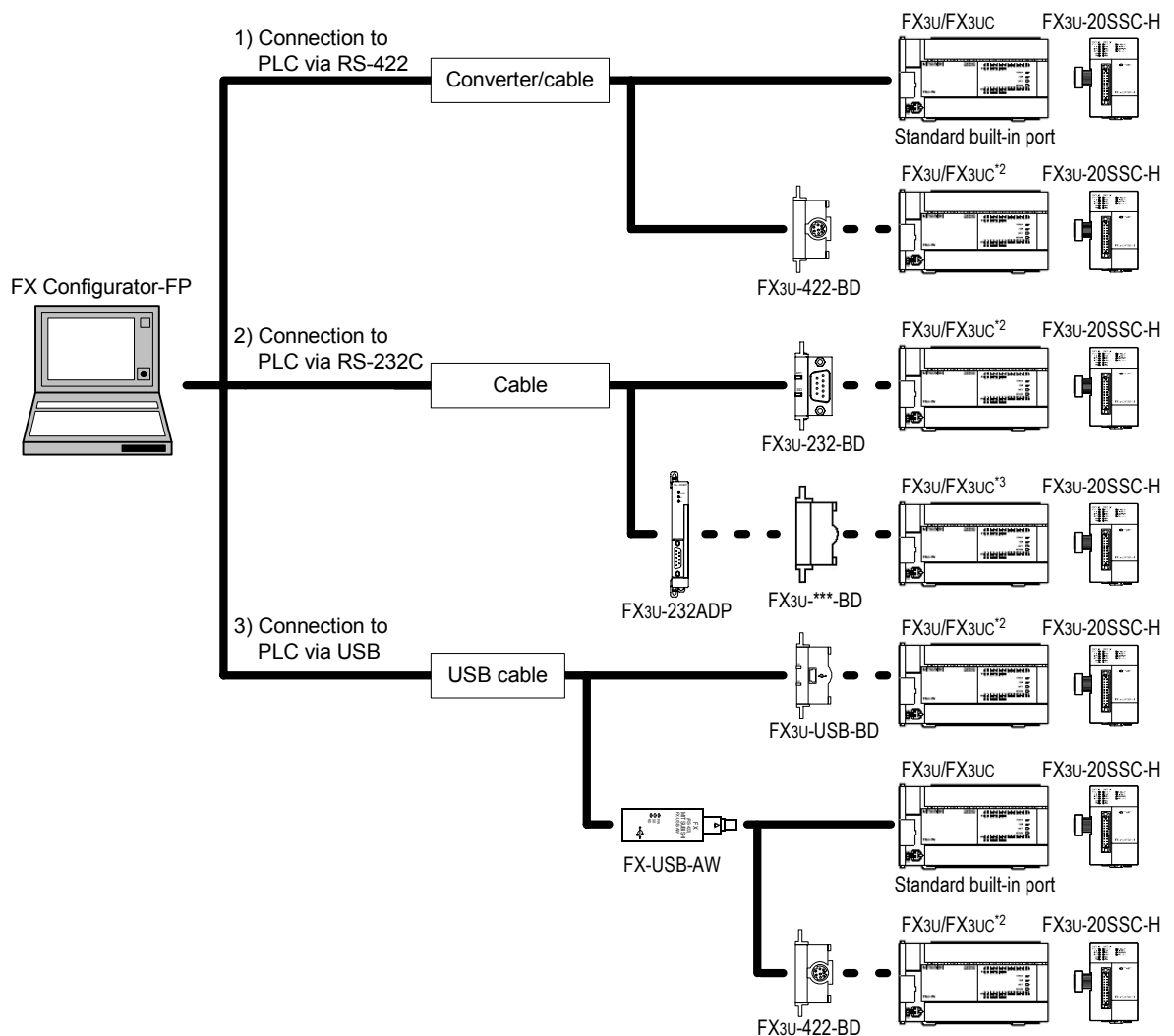



*2. Expansion boards (FX3U-***-BD) can not be attached to the FX3UC-□□MT/D and FX3UC-□□MT/DSS PLC.

*3. The FX3UC-□□MT/D and FX3UC-□□MT/DSS PLC can be attached to the FX3U-232ADP without an expansion board (FX3U-***-BD).

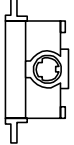

1	Introduction
2	Install Uninstall Start&Exit
3	Window and Operation Config
4	Creating Files
5	Data set
6	Setting The Connection
7	Data flow And Procedure
8	Debug In the Positioning
9	Print
10	Edit Function In data

1) The equipment for RS-422 connection

Personal Computer Connector	Converter/Cable			PLC Connector
	RS-232C Cable	Converter (interface)	RS-422 Cable	
D-SUB 9Pin	F2-232CAB-1[3m(9'10")]  (D-SUB 9Pin ⇔ D-SUB 25Pin)	FX-232AWC-H 	FX-422CAB0[1.5m(4'11")]  (D-SUB 25Pin ⇔ MINI DIN 8Pin)	Built-in dedicated programming connector of the main unit <hr/> FX3U-422-BD 

→ When using FX3U-422-BD, refer to the cautions on communication settings

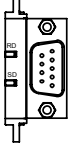



2) The equipment for RS-232C connection

Personal computer connector	RS-232C Cable	PLC Connector
D-SUB 9Pin	FX-232CAB-1[3m(9'10")]  (D-SUB 9Pin ⇔ D-SUB 9Pin)	FX3U-232-BD  <hr/> FX3U-232ADP*1 

→ When using FX3U-232-BD, FX3U-232ADP, refer to the cautions on communication settings

*1. An expansion board is necessary for FX3U-232ADP.

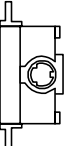
3) The equipment for USB connection

Personal Computer Connector	Converter/Cable		PLC Connector
	USB Cable*2	Converter (interface)	
USB	 (USB connector A plug [male] ⇔ MINI B plug [male])	FX-USB-AW*3 	Built-in dedicated programming connector of the main unit <hr/> FX3U-422-BD 
		—	FX3U-USB-BD*3 

→ When using FX3U-USB-BD, refer to the cautions on communication setting

*2. The USB cable comes with FX-USB-AW and FX3U-USB-BD.

*3. For the applicable Windows® Operating Systems, refer to each manual.

Cautions on communication setting

Do not change the communication settings for outside modules via parameters or sequence program. If changed, a communication error occurs between FX Configurator-FP and PLC (20SSC-H).

- 1) Check that the format of the communication connector to be used is correct.
(D8120, D8400, D8420 = K0)
Also, with peripheral devices, check that parameters for communication setting are correct.

How to check parameters with GX Developer

A check mark to [Operate communication setting] on [PLC system (2)] tab in [PLC parameter] of GX Developer disables the communication through the selected port between FX Configurator-FP and PLC(20SSC-H). When the communication fails, write the parameter that clears the check box [Operate communication setting] to the PLC via the built-in dedicated programming connector with GX Developer.

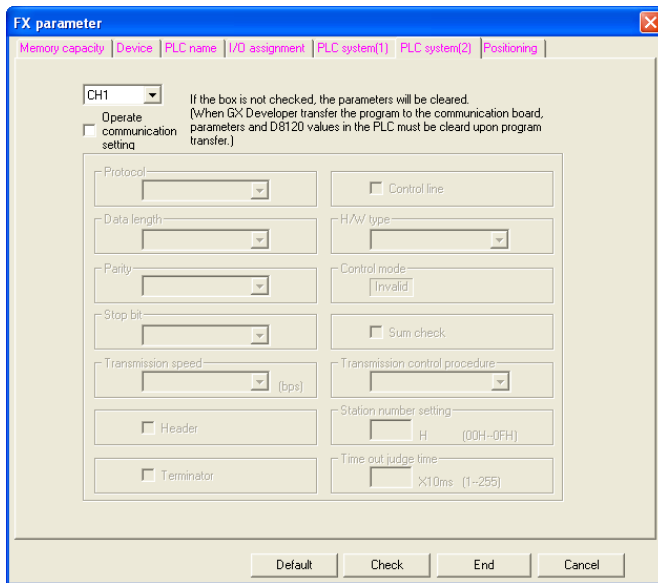

When the PLC type of the project is the FX3U(C), the channel specification (CH1/CH2) combo box appears. When using the FX3U-422-BD, FX3U-232-BD, FX3U-USB-BD or the first FX3U-232ADP connected to the FX3U-CNV-BD, set CH1 and check the settings.

When using the FX3U-232ADP connected to other than the FX3U-CNV-BD or the second FX3U-232ADP connected to the FX3U-CNV-BD, set CH2 and check the settings.

- 2) Check that RS and RS2 instructions are not programmed for the corresponding communication connector.
Do not execute RS and RS2 instructions in this case.
- 3) When an inverter communication instruction is programmed for the corresponding communication connector, delete the instruction first, and reboot the PLC's power.

2. Connection via GOT

This subsection shows the system configurations for Connection via GOT*1.

→ For the connection equipment for the personal computer, GOT1000 Series and PLC, refer to the GOT1000 series Manual.

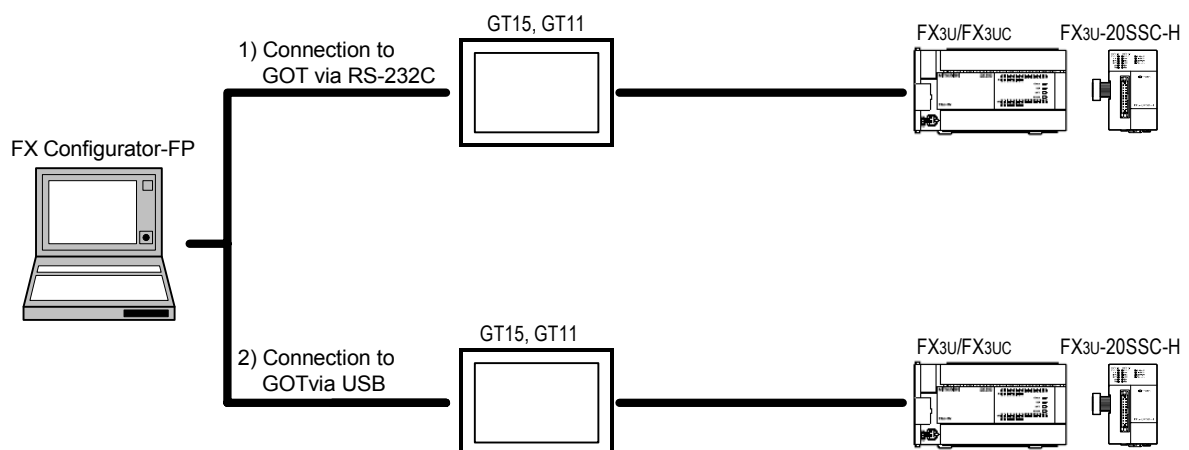

*1. Connection via GOT supported by GT15, GT11 of GOT1000 Series only.

1	Introduction
2	Install Uninstall Start&Exit
3	Window and Operation Config
4	Creating Files
5	Data set
6	Setting The Connection
7	Data flow And Procedure
8	Debug In the Positioning
9	Print
10	Edit Function In data

1.3.2 Applicable models

- FX3U-20SSC-H type positioning module
- Servo amplifier, applicable to SSCNET III (up to 2pcs)
Connect these servo amplifiers to the FX3U-20SSC-H via SSCNET III.

1.3.3 Operating System Requirements

Item	Description
OS	Microsoft® Windows® 95 English version (Service Pack 1 or later)
	Microsoft® Windows® 98 English version
	Microsoft® Windows® Millennium Edition English version
	Microsoft® WindowsNT® 4.0 Workstation English version (Service Pack 3 or later)
	Microsoft® Windows® 2000 professional English version
	Microsoft® Windows® XP English version (Home Edition or Professional)
	Microsoft® Windows® Vista English version (Home Basic, Home Premium, Business, Ultimate or Enterprise)* ¹
PC main body	Microsoft® Windows® 95: CPU Pentium 133MHz or higher
	Microsoft® Windows® 98: CPU Pentium 133MHz or higher
	Microsoft® Windows® Millennium Edition: CPU Pentium 150 MHz or higher
	Microsoft® WindowsNT® 4.0: CPU Pentium 133MHz or higher
	Microsoft® Windows® 2000: CPU Pentium 133MHz or higher
	Microsoft® Windows® XP: CPU Pentium 300MHz or higher
	Microsoft® Windows® Vista* ¹ : CPU Pentium 1GHz or higher
Required memory	Microsoft® Windows® 95: 64MB or more
	Microsoft® Windows® 98: 64MB or more
	Microsoft® Windows® Millennium Edition: 64MB or more
	Microsoft® WindowsNT® 4.0: 64MB or more
	Microsoft® Windows® 2000: 64MB or more
	Microsoft® Windows® XP: 128MB or more
	Microsoft® Windows® Vista* ¹ : 1GB or more
Hard disk capacity	65MB or more
Disk drive	CD-ROM drive
Display	SVGA (800 × 600) or higher* ²
Interface	RS-232C port or USB port
Printer	Printer, applicable to those OS above
Others	Mouse or other pointing device

*1. This Operating System is supported in FX Configurator-FP Ver.1.30 or later.

*2. When using Windows® Vista, the recommended resolution is 1024 x 768 or more.

2. Installation, Uninstallation, Startup and Exit

2.1 Installation

- 1** Insert the FX Configurator-FP CD-ROM into the CD-ROM drive.
- 2** Execute SETUP.EXE in the CD-ROM.
- 3** Follow the guidance on the PC display to complete the installation.

Caution

FX Configurator-FP requires the following version of GX Developer (SW□D5C-GPPW-E) or later:
FX Configurator-FP must be reinstalled if it was first installed prior to the applicable version of GX Developer.

Operating System	GX Developer (SW□D5C-GPPW-E) Version
Windows® 95, Windows® 98, Windows® Millennium Edition, WindowsNT® 4.0, Windows® 2000, Windows® XP	Ver.8.23Z or later
Windows® Vista	Ver.8.62Q or later

2.2 Uninstallation

- 1** Double-click [Add or Remove Programs] in the control panel.

Note

 - [Add/Remove Programs] appears in Windows® 95, Windows® 98, Windows® Millennium Edition, Windows NT® 4.0 and Windows® 2000.
 - [Programs] appears in Windows® Vista.
- 2** Select [Change or Remove Programs] in [Add or Remove Programs] window.

Note

 - Click [Add/Remove] on [Add/Remove Programs] property in Windows® 95, Windows® 98, Windows® Millennium Edition, Windows NT® 4.0 and Windows® 2000.
 - Double-click [Uninstall a program] of [Programs and Features] in Windows® Vista.
- 3** Click [FX Configurator-FP] to uninstall.

Note

Double-click [FX Configurator-FP] to uninstall in Windows® Vista, and go to step 5.
- 4** Click [Change/Remove] button.
- 5** Follow the guidance on the PC display to complete the uninstallation.

2.3 Starting FX Configurator-FP

To start up FX Configurator-FP, follow the 2 procedures below.

2.3.1 Starting FX Configurator-FP from the start menu.

- 1 Click [Start] → [All Programs] → [MELSOFT Application].
Select [FX Configurator-FP].

Note

[Programs] appears in Windows® OS versions other than XP (Professional and Home Edition) and Vista (Home Basic, Home Premium, Business, Ultimate and Enterprise).

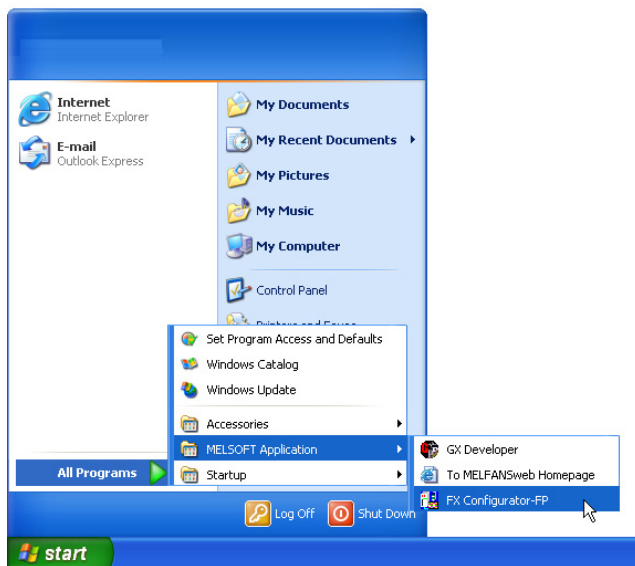

- 2 FX Configurator-FP starts up.

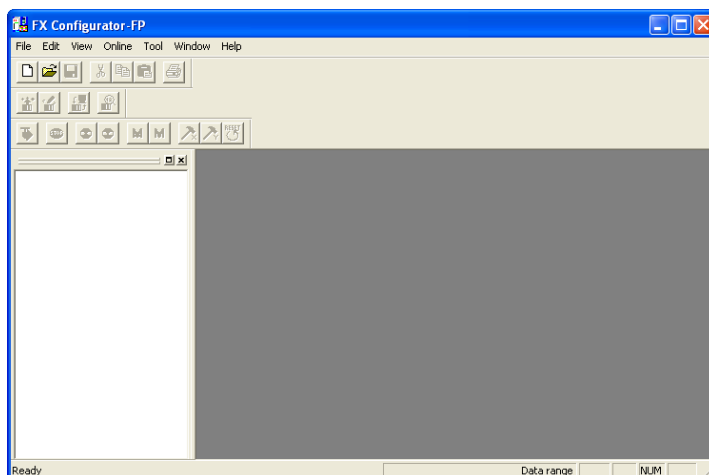

2.3.2 Starting FX-Configurator-FP from the tool menu in GX Developer.

- 1 Select [Tools] at the menu bar in GX Developer, click [FX special function utility] → [FX Configurator-FP] to start FX Configurator-FP.

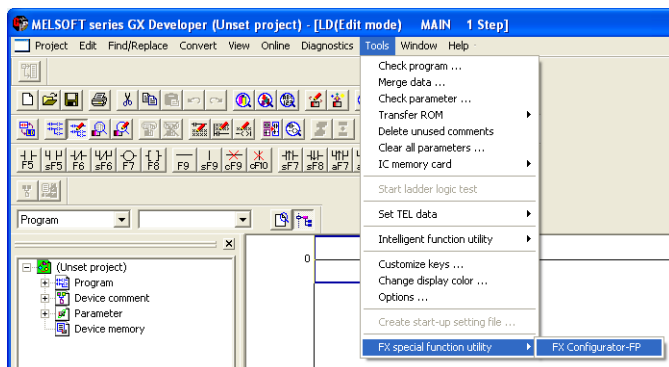

- 2 FX Configurator-FP starts up.

1	Introduction
2	Install Uninstall Start&Exit
3	Window and Operation Config
4	Creating Files
5	Data set
6	Setting The Connection
7	Data flow And Procedure
8	Debug In the Positioning
9	Print
10	Edit Function In data

2.4 Closing FX Configurator-FP

Note

When closing files or the application while online, i.e. Monitor Mode, Test Mode, the message bellow appears. Close the application while offline.



1 Select [File] → [Exit].

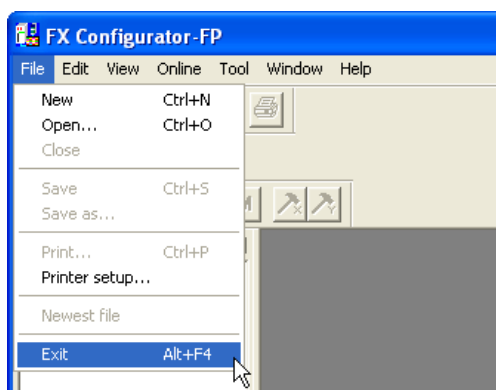

2 FX Configurator-FP closes.

How to close the application from the title bar

- Right-click on the title bar and select [Close].

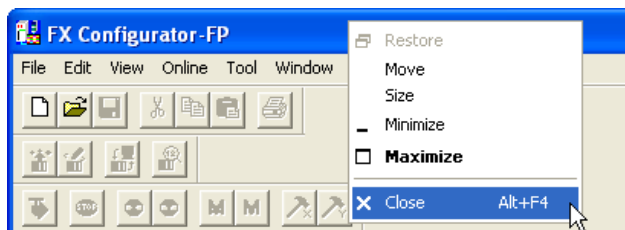

- Click  on the right edge of the title bar.

3. Window configuration and basic operation

3.1 Window configuration

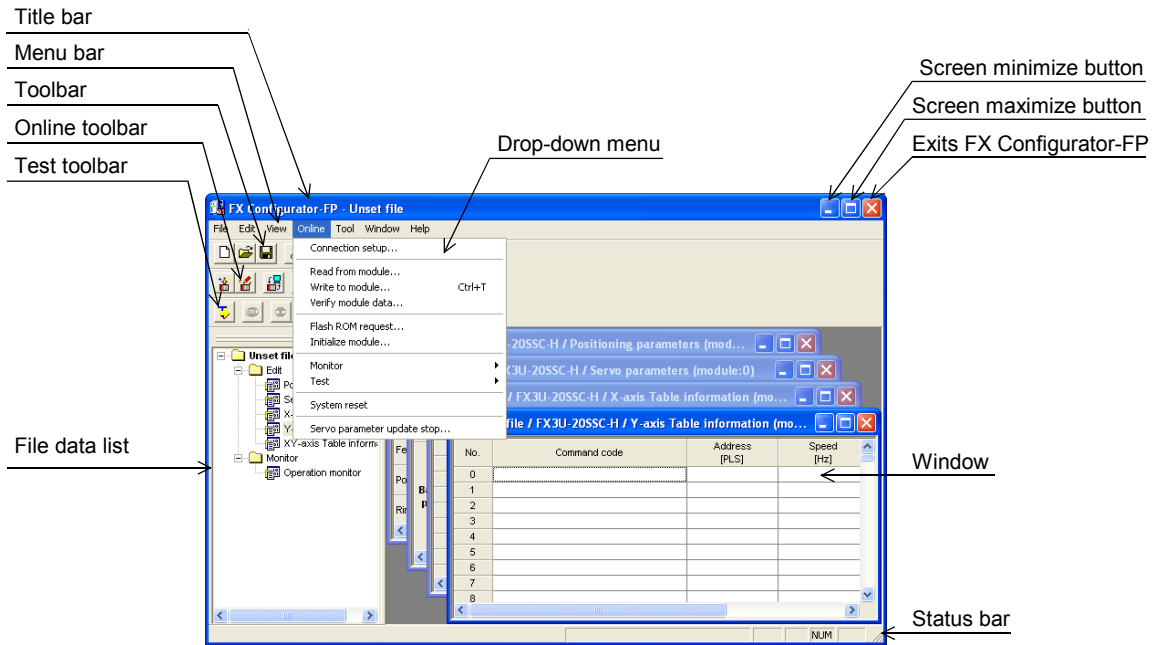

3.2 Menu configuration

1) File

File	
New	Ctrl+N
Open...	Ctrl+O
Close	
Save	Ctrl+S
Save as...	
Print...	Ctrl+P
Printer setup...	
Newest file	
Exit	Alt+F4

Creates a new file, reads a stored file and prints a content being edited.
Also shows the history of the files recently opened.

2) Edit

Edit	
Cut	Ctrl+X
Copy	Ctrl+C
Paste	Ctrl+V
Select all	Ctrl+A
Jump...	Ctrl+J
Clear row	
Clear column	
Insert row	
Delete row	

Cuts, copies, pastes and clears row/column, etc.

1	Introduction
2	Install Uninstall Start&Exit
3	Window and Operation Config
4	Creating Files
5	Data set
6	Setting The Connection
7	Data flow And Procedure
8	Debug In the Positioning
9	Print
10	Edit Function In data

3) View

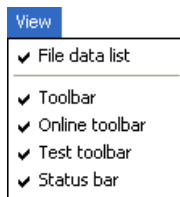

Shows /hides the tool bar, status bar and file data list.

4) Online

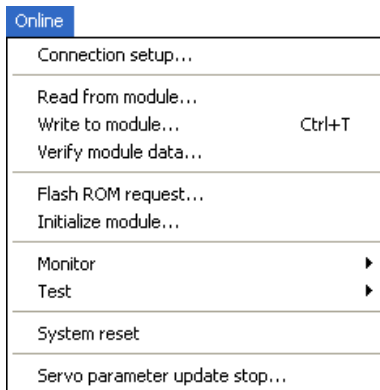

Reads/Writes/Verifies, monitors and tests the module data, etc.

5) Tool

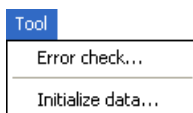

Enables Error check and data initialization.

6) Window

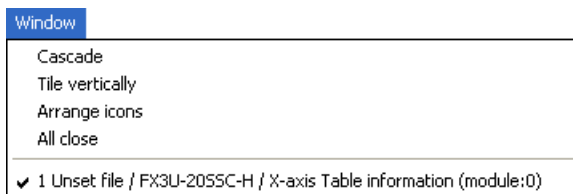

Cascades multiple windows and arranges icons.

7) Help



Shows product information.

3.3 Tool menus and tool button list

The tool bar has the menus below.
Click the toolbar to show (checked)/hide (unchecked).

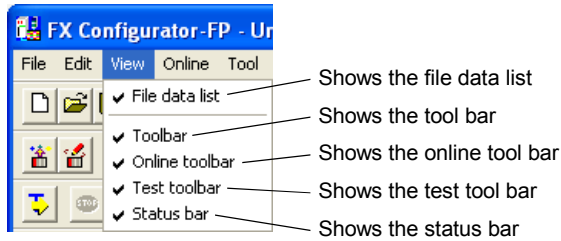









Tool button list

Tool bar menu	Tool button	Name	Description
Tool bar		New	Creates a new file
		Open	Opens an existing file
		Save	Saves the file being edited
		Cut	Cuts
		Copy	Copies
		Paste	Pastes
		Print	Prints
Online tool bar		Read from module	Reads from the module
		Write to module	Writes to the module
		Verify module data	Verifies the module data
		Monitor On/Off switch	Switches the table information window into monitor mode/edit mode
Test tool bar		Test On/Off switch	Switches into test mode
		All axis stop	Stops all axis
		Error reset X-axis	Resets errors at X-axis
		Error reset Y-axis	Resets errors at Y-axis
		m code off X-axis	Turns off the m code at X-axis
		m code off Y-axis	Turns off the m code at Y-axis
		Operation test X-axis	Test-operates X-axis
		Operation test Y-axis	Test-operates Y-axis
		System reset	Execute system reset

- 1 Introduction
- 2 Install Uninstall Start&Exit
- 3 Window and Operation Config
- 4 Creating Files
- 5 Data set
- 6 Setting The Connection
- 7 Data flow And Procedure
- 8 Debug In the Positioning
- 9 Print
- 10 Edit Function In data

3.4 Shortcut key list

	Item	Shortcut key	
File		New (N)	Ctrl + N
		Open (O)	Ctrl + O
		Save (S)	Ctrl + S
		Print (P)	Ctrl + P
Edit		Cut (T)	Ctrl + X
		Copy (C)	Ctrl + C
		Paste (V)	Ctrl + V
	–	Select all (A)	Ctrl + A
	–	Jump (J)	Ctrl + J
Online		Write to module (W)	Ctrl + T
		Monitor On/Off (S)	Ctrl + M

3.5 Basic operation

3.5.1 Basic operations in the file data list

[File data list] shows the currently opened file. To open the window, operate as follows. Right-click menu does not appear for all items below.

- 1) To display functions, double-click the file name, or click <+>. (In keyboard operation, select the file name and press <->)
- 2) To display the windows, double-click the function name, or click <+>. (In keyboard operation, select the function name and press <->)
- 3) To open the window, double-click the window name. (In keyboard operation, select the window name and press <Space> bar)

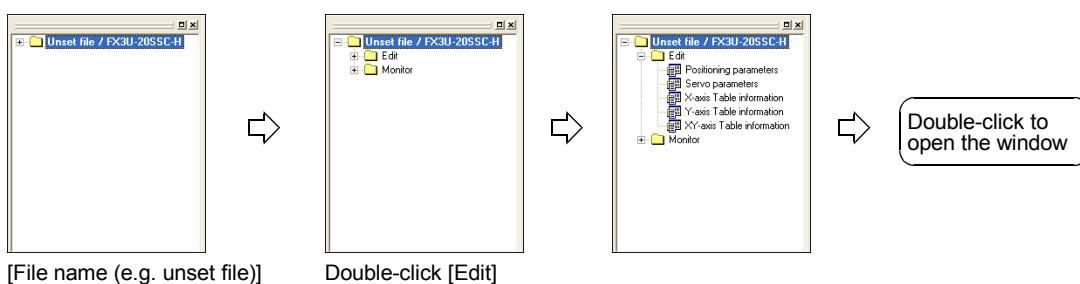

3.5.2 Basic operations in dialog box

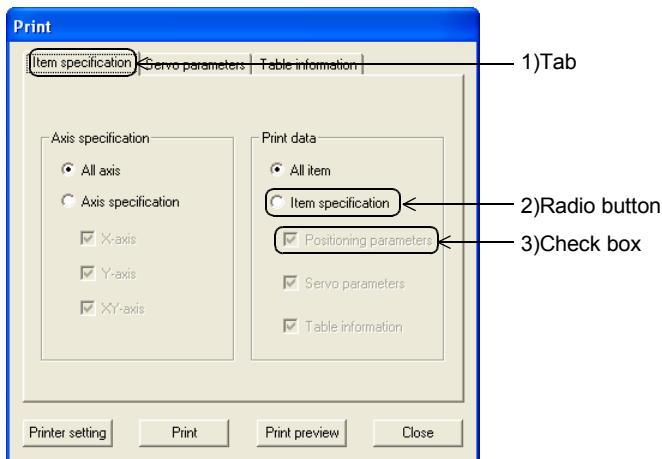

- 1) Tab
Click to switch the items.
- 2) Radio button
Click <O> to select 1 out of multiple items.
- 3) Check box
Click <□> to put ✓ mark to execute the item.

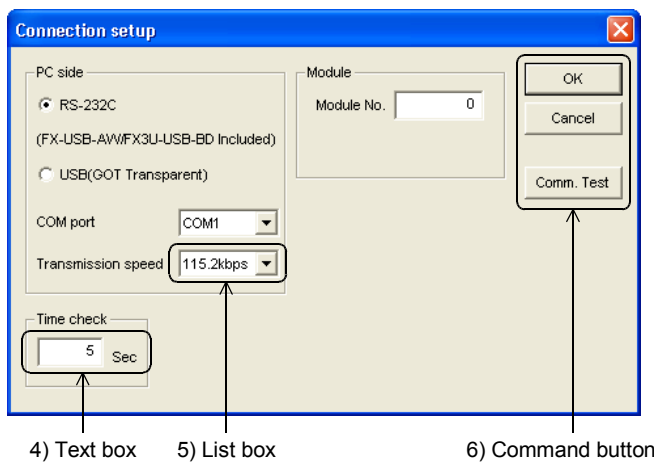

- 4) Text box
Input numbers/characters.
- 5) List box
Click ▼ to display the selection list, and click the item to select.
- 6) Command button
Command buttons appears with <OK> and <Cancel>, etc. Click those buttons to execute.

Note

In keyboard operations, select the item with <Tab> key. To select more items, use <<->, <->, <↑>, <↓> keys.

3.6 Help

This function shows FX Configurator-FP version in the product information.

1 Select [Help] → [Product information].

The product information appears.



1	Introduction
2	Install Uninstall Start&Exit
3	Window and Operation Config
4	Creating Files
5	Data set
6	Setting The Connection
7	Data flow And Procedure
8	Debug In the Positioning
9	Print
10	Edit Function In data

4. Creating files

FX Configurator-FP sets and controls the data in the table below.

Data	Description
Positioning parameter	Parameters for positioning operations, i.e. pulse rate, feed rate and maximum speed of 20SSC-H
Table information	Setting data for table operations of X/Y/XY-axis
Servo parameter	Data to be transferred from 20SSC-H to servo amplifiers, including servo amplifier series, gain/filter, expansion, I/O, basic setting parameters.

Caution

When creating and saving-as files, the characters and symbols below are not available for the file paths and names.

/, :, * " < > | \ COM LPT AUX CON PRN NUL CLOCK

4.1 Creating a new file

4.1.1 Creating a new file

This subsection shows how to create a new file.

Caution

When creating a new file while other files are opened, the following messages appear.

- 1) When the opened file is not changed



- Click <Yes> to close the current file, and to create a new file.
- Click <No> to cancel the operation.

- 2) When the opened file is changed



- Click <Yes> to close the current file without saving, and to create a new file.
- Click <No> to cancel the operation.

1 Follow any of the procedures below to create a new file.

- Click  (New).
- Select [File] → [New].

FX Configurator-FP creates a new file.

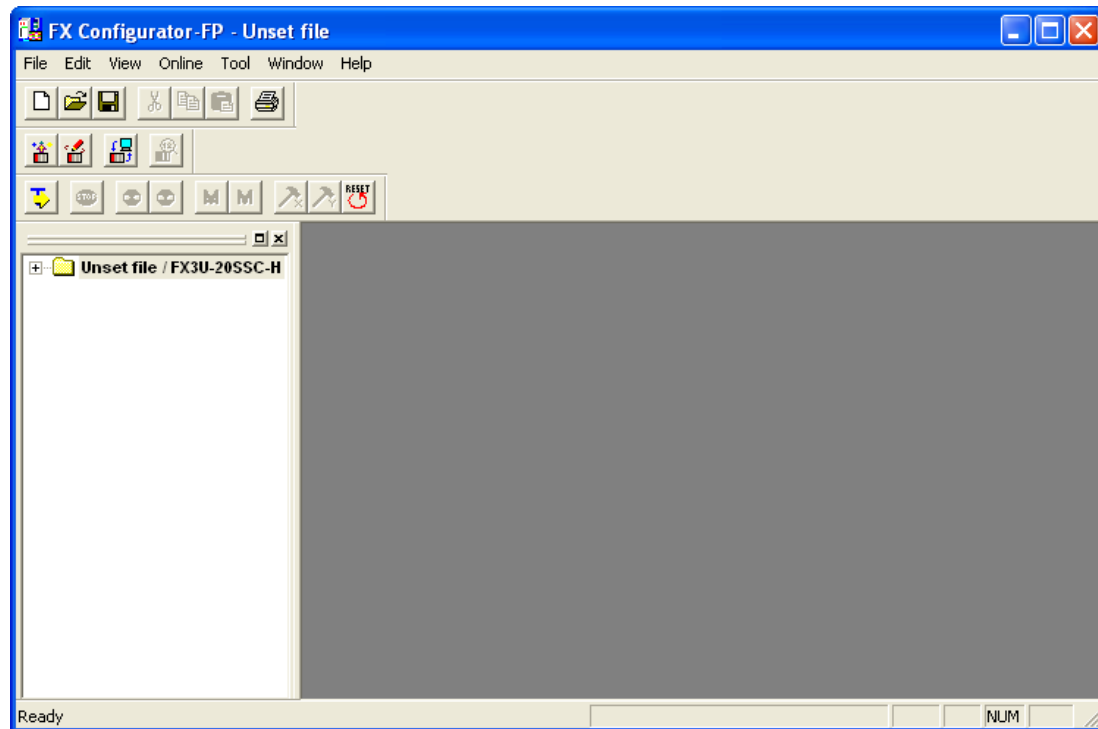

4.1.2 Creating a new file with the data inside 20SSC-H.

Creating a new file with the data stored in 20SSC-H.

1 Create a new file.

→ For the details, refer to Subsection 4.1.1.

2 Connect FX3U/3UC PLC with Personal Computer.

→ For the connection cables configuration, refer to Subsection 1.3.1

3 Select [Online] → [Connection setup].

Set the destination in [Connection setup] dialog box.

→ For the details, refer to Chapter 6.

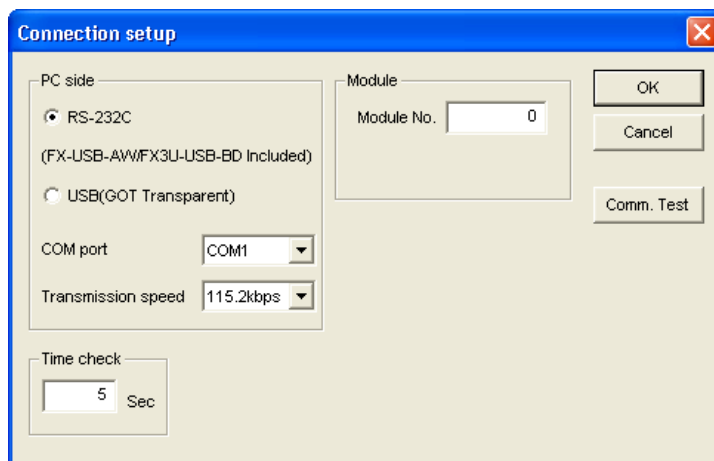

4 Click <Comm. Test>.

Check that the communication is properly executed.

5 Click <OK>.

[Connection setup] dialog box closes.

6 Select [Online] → [Read from module], and specify the data to be read.

→ For the details, refer to Section 7.2.

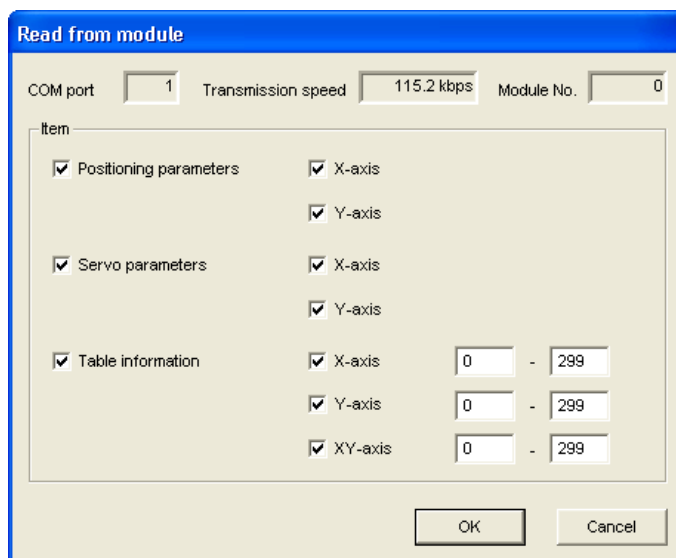

7 Click <OK>.

The specified data is read out.

4.2 Opening a stored file

Opening a stored file.

Caution

When opening a stored file while other files are opened, the following messages appear.

1) When the opened file is not changed



- Click <Yes> to close the current file, and to open a stored file.
- Click <No> to cancel the operation.

2) When the opened file is changed

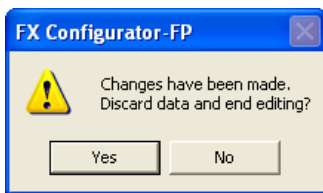

- Click <Yes> to close the current file without saving, and to open a stored file.
- Click <No> to cancel the operation.

Other messages

Messages	Conditions
The allowable No. of characters has been exceeded. Set to less than 150 characters	The total amount of the character in the file path and name exceeded 150 characters
Selected file type is not supported	The extension of the selected file is not supported
Failed to open the file. Because the module-type is not supported	Can't read the file when the module type is not supported
This file has been made with a newer product version. There is a possibility the data may not be read correctly.	The file was saved by different FX Configurator-FP version. The file can be opened by clicking <OK> but will not be opened properly <countermeasures> Use the FX Configurator-FP version that is the same as or later than the FX Configurator-FP version used to create the file.
Failed to open the file. The following causes are thought <ul style="list-style-type: none"> • The specified file does not exist • The data in the file is completely damaged • The data is created by other S/W 	Could not open the file. The following causes are thought <ul style="list-style-type: none"> • The specified file does not exist • The data in the file is completely damaged • The data is created by other S/W

1 Follow any of the procedures below to open a stored file.

- Click  (Open).
- Select [File] → [Open].

The dialog box to open a file appears.

2 Select a file to open.

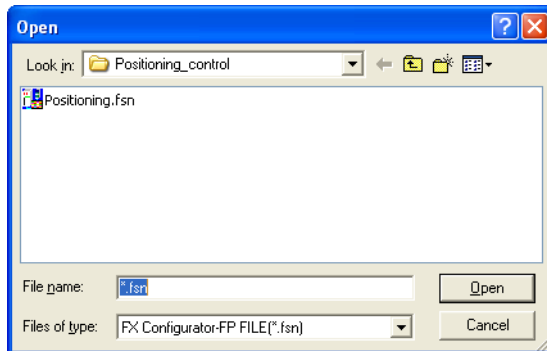

Item	Description
Look in	Select a file location
File name	Enter the file name to open
Files of type	Select the files of type to open FX Configurator-FP FILE (*.fsn) : opens data for FX Configurator-FP

3 Click [Open].

The selected file opens.

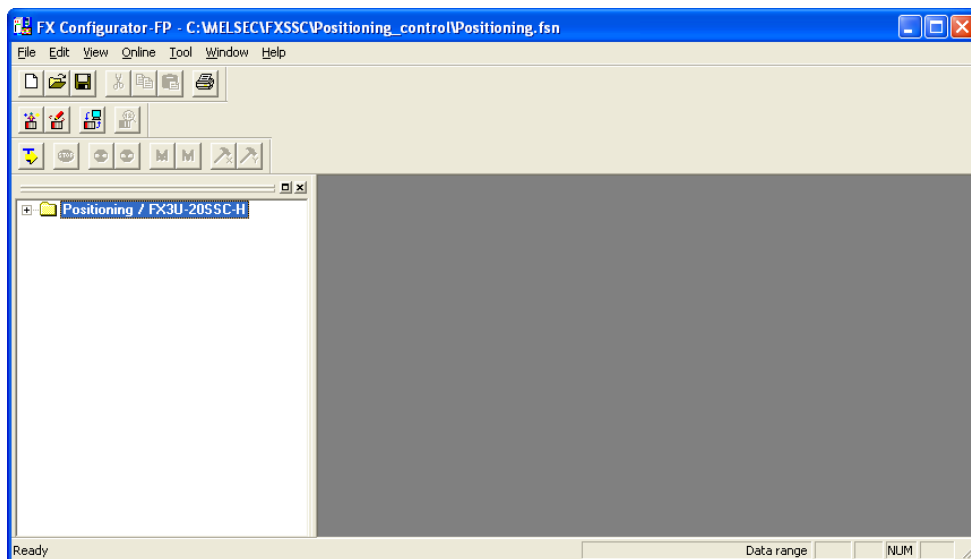

Opening a file in Recent file history

A file in Recent file history can be opened. The history shows the latest 4 files. [Recent file] appears at the default setting. The number of files simultaneously opened is a single file only.

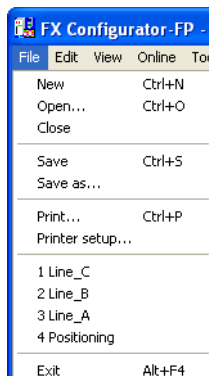

4.3 File storage

Storable information

- Versions of files
- Module type
- Positioning parameters
- Servo parameters
- Table information
- Connection Destination

Messages

Messages	Conditions
The allowable No. of characters has been exceeded. Set to less than 150 characters	The total amount of the character in the file path and name exceeded 150 characters
Failed to save data to the file in selected drive. The following causes are thought. <ul style="list-style-type: none"> • The error occurred while saving project. • The target Memory is low. • The medium of selected drive is incorrect. 	Could not save the file. The following causes are thought <ul style="list-style-type: none"> • The specified file does not exist • The data in the file is completely damaged • The data is created by other S/W

4.3.1 Saving files

Saving stored files after editing.

1 Follow any of the procedures below to save as files.

- Click  (Save).
- Select → [File] → [Save].

The currently opened file is saved.

When using a floppy disk (FD).

When saving a file in a floppy disk, Floppy disk itself needs the same amount of another free space with the file to be saved, so floppy disk sometimes does not save the file due to the out of disk space.

When the file cannot be saved in floppy disk, save the file once in the hard drive of PC, and copy the file to floppy disk.

4.3.2 Saving as files

Saving newly created files, and stored files in different names.

1 Select [File] → [Save as].

The dialog box to save as files appears.

2 Select a file location and file name to save as.

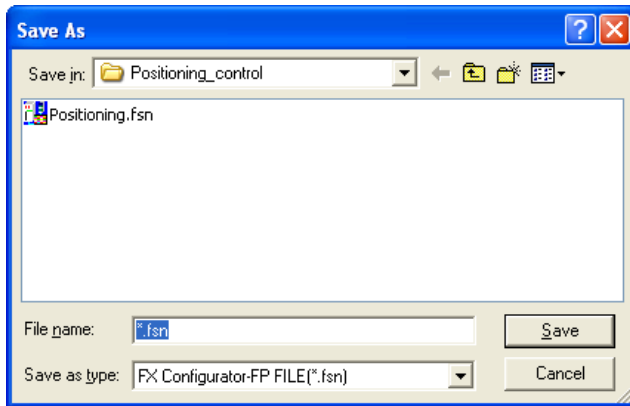

Item	Description
Look in	Select a file location
File name	Enter the file name to open
Files of type	Select the files of type to open FX Configurator-FP FILE (*.fsn) : opens data for FX Configurator-FP

Caution

- Set the total amount of the character in the file path and name at 150 characters or below.
- The characters and symbols below are not available for file names.

/, ;, *, " < > | \ COM LPT AUX CON PRN NUL CLOCK

3 Click [Save].

Files are saved as in the specified name.

4.4 Closing files

Closing currently opened files.

1 Select [File] → [Close].

2 A message appears depending on the situation. Follow the message.

1) When the opened file is not changed



- Click <Yes> to close the current file.
- Click <No> to cancel the operation.

2) When the opened file is changed



- Click <Yes> to close the current file without saving.
- Click <No> to cancel the operation.

5. Data set

This chapter explains the procedures to set and error-check Positioning parameters, Servo parameters and Table information.

→ For the detail on Positioning parameters and Table information, refer to FX3U-20SSC-H user's manual.

→ For the detail on Servo parameters, refer to the manual of servo amplifier to be used.

5.1 User unit and Converted pulse data.

5.1.1 User unit

User units appear as follows, depending on the unit setting and position data magnification.

Position data magnification	Unit settings (Positioning units)				Unit settings (Velocity units)			
	PLS	μm	0.0001 inch	mdeg	Hz	cm/min	inch/min	10deg/min
1 times	PLS	μm	×0.0001 inch	mdeg	Hz	cm/min	inch/min	×10deg/min
10 times	×10PLS	×10μm	×0.001 inch	×10mdeg				
100 times	×100PLS	×100μm	×0.01 inch	×100mdeg				
1000 times	×1000PLS	mm	×0.1 inch	deg				

5.1.2 Converted pulse data

For items within a data set range, make sure to set the value does not overlap the range of converted pulse data.

Pulse conversion procedures are as follows.

1) Travel distance

Travel distance by converted pulse data =

$$\text{Travel distance}(\mu\text{m}, 10^{-4}\text{inch}, \text{mdeg}) \times \text{Position data magnification} \times (\text{Pulse rate} \div \text{Feed rate})$$

2) Operation speed

Operation speed by converted pulse data =

$$\text{Operation speed}(\text{cm/min}, \text{inch/min}, 10\text{deg/min}) \times 10^4 \times (\text{Pulse rate} \div \text{Feed rate}) \div 60$$

5.1.3 Rotation and operation speed of servo motor (Converted pulse data)

When setting operation speed (incl. Maximum speed, JOG speed, Zero return speed), make sure to set the value within the Max. rotation speed range of servo motor. The formula to calculate the rotation speed of servo motor from the operation speed (Converted pulse data) is as follows.

Rotation speed of the servo motor (r/min) =

$$\text{operation speed by converted pulse data} \times 60 \div \text{resolution per servo motor rotation.}$$

Servo amplifier	Resolution per servo motor rotation
MR-J3B	262144

5.2 Setting positioning parameters

Setting parameters (positioning parameters) for positioning control.

- 1 Double-click [File name] → [Edit] → [Positioning parameters] in the file data list.

An edit window for positioning parameters appears.

- 2 Set the items for positioning parameters.

To enter texts and select items, double-click the cell.

→ For positioning parameter details, refer to FX3U-20SSC-H User's Manual.

Item		X-axis	Y-axis
System of units		0:Motor(PLS,Hz)	0:Motor(PLS,Hz)
Pulse rate	Pulse per rotation	262144 PLS/REV	262144 PLS/REV
Feed rate	Travel per rotation	52428800 PLS/REV	52428800 PLS/REV
Position data magnification		0:X 1 times	0:X 1 times
Ring counter setting		0:Invalid	0:Invalid
Ring counter upper limit value		359999 PLS	359999 PLS
Maximum speed		4000000 Hz	4000000 Hz
JOG speed		2000000 Hz	2000000 Hz
JOG instruction evaluation time		300 ms	300 ms
ACC/DEC mode		0:Trapezoid ACC/DEC	0:Trapezoid ACC/DEC
ACC time		200 ms	200 ms
DEC time		200 ms	200 ms
Interpolation time constant		100 ms	100 ms
Sudden stop deceleration time		200 ms	200 ms
Sudden stop interpolation time constant		100 ms	100 ms
Sudden stop selection (STOP command)		0:Normal deceleration stop	0:Normal deceleration stop
Sudden stop selection (Software limit)		0:Normal deceleration stop	0:Normal deceleration stop
Sudden stop selection (PLC limit)		0:Normal deceleration stop	0:Normal deceleration stop
Sudden stop selection (Servo amplifier limit)		0:Normal deceleration stop	0:Normal deceleration stop
Interpolation gear ratio selection		0:X-axis	
Stop mode		0:Positioning end	0:Positioning end
Software limit(upper)		0 PLS	0 PLS
Software limit(lower)		0 PLS	0 PLS
FLS_RLS External input selection	Signal selection	0:Use signal via FX3U(C)	0:Use signal via FX3U(C)
	Signal logic	1:B-contact(servo amplifier)	1:B-contact(servo amplifier)
Torque limit		3000 x0.1 %	3000 x0.1 %
Servo ready check		1:Valid	1:Valid
Servo end check		1:Valid	1:Valid

1	Introduction
2	Install Uninstall Start&Exit
3	Window and Operation Config
4	Creating Files
5	Data set
6	Setting The Connection
7	Data flow And Procedure
8	Debug In the Positioning
9	Print
10	Edit Function In data

Servo end evaluation time		5000 ms	5000 ms
Positioning completion signal output waiting time		0 ms	0 ms
OPR mode		0:DOG	0:DOG
OPR direction		0:Decrease present value	0:Decrease present value
Machine zero point address		0 PLS	0 PLS
OPR speed(High speed)		4000000 Hz	4000000 Hz
OPR speed(Creep)		100000 Hz	100000 Hz
OPR torque limit value		3000 x0.1 %	3000 x0.1 %
OPR interlock setting		1:Valid	1:Valid
Zero signal count start timing		0:Backward end of DOG	0:Backward end of DOG
Zero signal count		1 PLS	1 PLS
DOG External input selection	Signal selection	0:Use signal via 20SSC-H	0:Use signal via 20SSC-H
	Signal logic	0:A-contact(servo amplifier)	0:A-contact(servo amplifier)
DOG switch input logic		0:A-contact(20SSC-H)	0:A-contact(20SSC-H)
Servo parameter transfer mode selection		0:Flash ROM -> Servo amp	0:Flash ROM -> Servo amp

Item		Description	Default value
System of unit		Sets the system of units for positioning for the X/Y-axis. 0: Motor (PLS, Hz) 1: Mechanical (μm, cm/min) 2: Mechanical (0.0001inch, inch/min) 3: Mechanical (mdeg, 10deg/min) 4: Composite (μm, Hz) 5: Composite (0.0001inch, Hz) 6: Composite (mdeg, Hz)	0:Motor (PLS, Hz)
Pulse rate	Pulse per rotation	Sets the pulse rate for the X/Y-axis. Set the resolution per servo motor rotation. Setting range : 1~200,000,000 PLS/REV	262,144 PLS/REV
Feed rate	Travel per rotation	Sets the feed rate for the X/Y-axis. Setting range : 1~200,000,000 [User unit]*1/REV	52,428,800 PLS/REV
Position data magnification		Sets the position data magnification for the X/Y-axis. 0: ×1 times 1: ×10 times 2: ×100 times 3: ×1000 times	0: ×1 times
Ring counter setting		Sets the Ring counter to valid/invalid for the X/Y-axis. 0: Invalid 1: Valid	0:Invalid
Ring counter upper limit value		Sets the Ring counter upper limit value for the X/Y-axis. Setting range :1~2,147,483,646 [User unit]*1	359999PLS
Maximum speed		Sets the maximum speed for the X/Y-axis. Set the speed at or below the maximum rotation speed*2 of servo motor. Setting range : 1~2,147,483,647 [User unit]*1 Set the value within 1~50,000,000Hz in the converted pulse data.	4,000,000Hz

Item	Description	Default value
JOG speed	Sets the JOG speed for the X/Y-axis. Set the speed at or below the maximum rotation speed*2 of servo motor. Setting range : 1~Maximum speed [User unit]**1 Set the value within 1~50,000,000Hz in the converted pulse data.	2,000,000Hz
JOG instruction evaluation time	Sets the JOG instruction evaluation time for the X/Y-axis. Setting range : 0~5000ms	300ms
ACC/DEC mode	Sets the ACC/DEC mode for the X/Y-axis. 0: Trapezoid ACC/DEC 1: Approximate S curve ACC/DEC	0:Trapezoid ACC/DEC
ACC time	Sets the ACC time for the X/Y-axis. Setting range : 1~5000ms	200ms
DEC time	Sets the DEC time for the X/Y-axis. Setting range : 1~5000ms	200ms
Interpolation time constant	Sets the interpolation time constant for the X/Y-axis. Setting range : 1~5000ms	100ms
Sudden stop deceleration time	Sets the sudden stop deceleration time for the X/Y-axis. Setting range : 1~5000ms	200ms
Sudden stop interpolation time constant	Sets the sudden stop interpolation time constant for the X/Y-axis. Setting range : 1~5000ms	100ms
Sudden stop selection (STOP command)	Set the stop method when the Stop command turns ON for the X/Y-axis. 0:Normal deceleration stop 1:Sudden stop	0:Normal deceleration stop
Sudden stop selection (Software limit)	Set the stop method when the software limit turns ON for the X/Y-axis. 0:Normal deceleration stop 1:Sudden stop	0:Normal deceleration stop
Sudden stop selection (PLC limit)	Set the stop method when the PLC limit turns ON for the X/Y-axis. 0:Normal deceleration stop 1:Sudden stop	0:Normal deceleration stop
Sudden stop selection (Servo amplifier limit)	Set the stop method when the Servo amplifier limit turns ON for the X/Y-axis. 0:Normal deceleration stop 1:Sudden stop	0:Normal deceleration stop
Interpolation gear ratio selection	Sets the interpolation gear ratio selection 0:X-axis 1:X-axis, Y-axis	0:X-axis
STOP mode	Sets the STOP mode for the X/Y-axis. 0: Positioning end 1: Remaining distance operation	0:Positioning end
Software limit (upper)	Sets the software limit (upper) address for the X/Y-axis. Setting range : -2,147,483,648~2,147,483,647 [User unit]**1 Set the value within -2,147,483,648~2,147,483,647PLS in the converted pulse data*1.	0 PLS
Software limit (lower)	Sets the software limit (lower) address for the X/Y-axis. Setting range : -2,147,483,648~2,147,483,647 [User unit]**1 Set the value within -2,147,483,648~2,147,483,647PLS in the converted pulse data.*1	0 PLS

1	Introduction
2	Install Uninstall Start&Exit
3	Window and Operation Config
4	Creating Files
5	Data set
6	Setting The Connection
7	Data flow And Procedure
8	Debug In the Positioning
9	Print
10	Edit Function In data

Item		Description	Default value
FLS,RLS External input selection	Signal selection	Sets the FLS and RLS signals to be used/not used in the servo amplifier. The FLS and RLS on PLC side are always used. 0:Use signal via FX3U(C) 1:Use signal via FX3U(C) & servo amp	0:Use signal via FX3U(C)
	Signal logic	Sets the FLS and RLS signal logic in the servo amplifier. 0: A-contact (servo amplifier) 1: B-contact (servo amplifier)	1:B-contact (servo amplifier)
Torque limit		Sets the torque limit for the X/Y-axis. Setting range : 1~10000×0.1%	3000×0.1%
Servo ready check		Sets the servo ready check valid/invalid for the X/Y-axis. 0: Invalid 1: Valid	1:Valid
Servo end check		Sets the servo end check valid/invalid for the X/Y-axis. 0:Invalid 1:Valid	1:Valid
Servo end evaluation time		Sets the servo end evaluation time for the X/Y-axis. Setting range : 1~5000ms	5000ms
Positioning completion signal output waiting time		Sets the positioning completion signal output waiting time for the X/Y-axis. Setting range : 0~5000ms	0ms
OPR mode		Sets the OPR mode for the X/Y-axis. 0:DOG 1: Data set 2: Stopper #1 3: Stopper #2	0:DOG
OPR direction		Sets the OPR direction for the X/Y-axis. 0: Decrease present value 1: Increase present value	0:Decrease present value
Machine zero point address		Sets the OPR address for the X/Y-axis. Setting range : -2,147,483,648~2,147,483,647 [User unit]*1 Set the value within -2,147,483,648~ 2,147,483,647PLS in the converted pulse data.*1	0 PLS
OPR speed (High speed)		Sets the OPR speed (High speed) for the X/Y-axis. Set the speed at or below the maximum rotation speed*2 of the servo motor. Setting range : 1~Maximum speed [User unit]*1 Set the value within 1~50,000,000Hz in the converted pulse data. *1	4,000,000Hz
OPR speed (Creep)		Sets the OPR speed (Creep) for the X/Y-axis. Set the speed at or below the maximum rotation speed*2 of the servo motor. Setting range : 1~OPR speed (High speed) [User unit]*1 Set the value within 1~50,000,000Hz in the converted pulse data. *1	100,000Hz
OPR torque limit value		Sets the torque limit for the X/Y-axis in during OPR. Setting range : 1~10000×0.1%	3000×0.1%
OPR interlock setting		Sets the OPR interlock to valid/invalid. 0: Invalid 1: Valid	1:Valid
Zero signal count start timing		Sets the Zero signal count start timing for the X/Y-axis. 0: Backward end of DOG 1: Forward end of DOG	0: Backward end of DOG
Zero signal count		Sets the Zero signal count for the X/Y-axis. Setting range : 0~32767PLS	1 PLS

Item		Description	Default value
DOG External input selection	Signal selection	Sets the DOG signal to be used. 0: Use signal via 20SSC-H 1: Use signal via Servo Amplifier	0: Use signal via 20SSC-H
	Signal logic	Sets the DOG signal logic for the servo amp. 0: A-contact (servo amplifier) 1: B-contact (servo amplifier)	0: A-contact (servo amplifier)
DOG switch input logic		Sets the DOG switch input logic for the X/Y-axis. 0: A-contact (20SSC-H) 1: B-contact (20SSC-H)	0: A-contact (20SSC-H)
Servo parameter transfer mode selection		Sets the Servo parameter transfer mode selection for the X/Y-axis. 0: Flash ROM → Servo amp 1: BFM → Servo amp	0:Flash ROM Servo amp

*1. For the user unit and the converted pulse data, refer to the following.

→ Refer to Section 5.1.

*2. For the servo motor rotation speed and the operation speed (converted pulse data), refer to the following.

→ Refer to Subsection. 5.1.3

Display colors of the positioning parameters edit window

Display colors of the positioning parameters edit window have meanings as follows.

Display color of the characters and frame	Description
Blue	Default settings.
Black	Nondefault settings with no error.
Red	The content has a setting range error.
Gray	<p>NA items.</p> <ul style="list-style-type: none"> When [System of units] is [Motor], [Pulse rate] and [Feed rate] are not available. When [Ring counter setting] is [0: Invalid], [Ring counter upper limit value] is not available. Sets the [Interpolation gear ratio selection] for the X-axis only. The Y-axis is not available. When [Signal selection] in [FLS,RLS External input selection] is [0: Use signal via FX3U(C)]. [Signal logic] is not available. When [Servo end check] is [0: Invalid], [Servo end evaluation time] is not available. When [Signal selection] in [DOG External input selection] is [0: Use signal via 20SSC-H], [Signal logic] is not available. When [Signal selection] in [DOG External input selection] is [1: Use signal via Servo Amplifier], [DOG switch input logic] is not available.

1	Introduction
2	Install Uninstall Start&Exit
3	Window and Operation Config
4	Creating Files
5	Data set
6	Setting The Connection
7	Data flow And Procedure
8	Debug In the Positioning
9	Print
10	Edit Function In data

5.3 Setting servo parameters

Setting the parameters (servo parameters) to transfer from 20SSC-H to servo amplifiers via SSCNET III.

1 Double-click [File name] → [Edit] → [Servo parameters] in the file data list.

An edit window for servo parameters appears.

2 Set the items of servo parameters.

To enter texts and select items, double-click the cell.

→ For servo parameter details, refer to the FX3U-20SSC-H User's Manual and Servo Amplifier Instruction Manuals.

Servo series [Servo parameters (Basic setting)]

This parameter must be set to transfer information between 20SSC-H and the servo amplifier. Set the servo parameters according to the servo amplifier being used.

Unset file / FX3U-20SSC-H / Servo parameters (module:0)					
Kind	Item		X-axis	Y-axis	
Servo amplifier series	Servo amplifier series		0:Not used	0:Not used	
	Regenerative brake option	Selection of regenerative brake option	00: Regenerative brake option is not used	00: Regenerative brake option is not used	
Basic setting parameters	Absolute position detection system	Selection of absolute position detection system	0:Used in incremental system	0:Used in incremental system	
	Function selection A-1	Output signal 3 function selection	0:Signal allocated by Output signal 3 function selection	0:Signal allocated by Output signal 3 function selection	
		Servo forced stop selection	0:Valid (Use the forced stop signal.)	0:Valid (Use the forced stop signal.)	
	Auto tuning	Gain adjustment mode setting	1:Auto tuning mode 1	1:Auto tuning mode 1	
	Auto tuning response		12:37.0Hz	12:37.0Hz	
	In-position range		100 pulse	100 pulse	
	Rotation direction selection		0:Forward rotation (CCW) with the increase of the positioning address.	0:Forward rotation (CCW) with the increase of the positioning address.	
	Encoder output pulse		4000 pulse/rev	4000 pulse/rev	
	Gain/filter parameters	Adaptive tuning mode (Adaptive filter II)	Filter tuning mode selection	0:Filter OFF	0:Filter OFF
		Vibration suppression control filter tuning mode (Advanced vibration suppression control)	Vibration suppression control tuning mode	0:Vibration suppression control OFF	0:Vibration suppression control OFF
Feed forward gain		0 %	0 %		
Ratio of load inertia moment to servo motor inertia moment		7.0 times	7.0 times		
Model loop gain		24 rad/s	24 rad/s		
Position loop gain		37 rad/s	37 rad/s		
Speed loop gain		823 rad/s	823 rad/s		
Speed integral compensation		33.7 ms	33.7 ms		
Speed differential compensation		980	980		
Machine resonance suppression filter 1		4500 Hz	4500 Hz		
Notch form selection 1		Notch depth selection	0:Deep(-40dB)	0:Deep(-40dB)	
		Notch width selection	0:Standard(a=2)	0:Standard(a=2)	
Machine resonance suppression filter 2		4500 Hz	4500 Hz		
Notch form selection 2		Machine resonance suppression filter 2 selection	0:Invalid	0:Invalid	
		Notch depth selection	0:Deep(-40dB)	0:Deep(-40dB)	
	Notch width selection	0:Standard(a=2)	0:Standard(a=2)		

Gain/filter parameters	Low-pass filter		3141 rad/s	3141 rad/s
	Vibration suppression control vibration frequency setting		100.0 Hz	100.0 Hz
	Vibration suppression control resonance frequency setting		100.0 Hz	100.0 Hz
	Low pass filter selection	Low pass filter selection	0:Automatic setting	0:Automatic setting
	Slight vibration suppression control selection	Slight vibration suppression control selection	0:Invalid	0:Invalid
		PI-PID control switch-over	0:PI control is always valid.	0:PI control is always valid.
	Gain changing selection	Gain changing selection	0:Invalid	0:Invalid
	Gain changing condition		10	10
	Gain changing time constant		1 ms	1 ms
	Gain changing ratio of load inertia moment to servo motor inertia moment		7.0 times	7.0 times
	Gain changing position loop gain		37 rad/s	37 rad/s
	Gain changing speed loop gain		823 rad/s	823 rad/s
	Gain changing speed integral compensation		33.7 ms	33.7 ms
	Gain changing vibration suppression control vibration frequency setting		100.0 Hz	100.0 Hz
Gain changing vibration suppression control resonance frequency setting		100.0 Hz	100.0 Hz	
Extension setting parameters	Error excessive alarm level		3 rev	3 rev
	Electromagnetic brake sequence output		0 ms	0 ms
	Encoder output pulses selection	Encoder pulse output phase changing	0:CCW progress to A phases 90 degree	0:CCW progress to A phases 90 degree
		Encoder output pulse setting selection	0:Output pulse setting	0:Output pulse setting
	Function selection C-1	Encoder cable communication system selection	0:Two-wire type	0:Two-wire type
	Function selection C-2	Motor-less operation selection	0:Invalid	0:Invalid
	Zero speed		50 r/min	50 r/min
	Analog monitor output 1	Analog monitor (MD1) output selection	0:Servo motor speed(+/-8V/Max. speed)	0:Servo motor speed(+/-8V/Max. speed)
	Analog monitor output 2	Analog monitor (MD2) output selection	1:Torque(+/-8V/Max. torque)	1:Torque(+/-8V/Max. torque)
	Analog monitor 1 offset		0 mV	0 mV
	Analog monitor 2 offset		0 mV	0 mV
Function selection C-4	OPR set condition selection	1:It is not necessary to pass through the Z phase after the power on.	1:It is not necessary to pass through the Z phase after the power on.	
I/O setting parameters	Output signal device selection 1	Output signal 1 function selection	5:MBR	5:MBR
	Output signal device selection 2	Output signal 2 function selection	4:INP	4:INP
	Output signal device selection 3	Output signal 3 function selection	3:ALM	3:ALM

Display colors of the servo parameters edit window

Display colors of the servo parameters edit window have meanings as follows.

Display color of the characters and frame	Description
Blue	Default settings.
Black	Nondefault settings with no error.
Red	The content has a setting range error.
Gray	NA items. • Depending on the [Gain Changing Selection] content, [Gain Changing Condition] is not available.

1	Introduction
2	Install Uninstall Start&Exit
3	Window and Operation Config
4	Creating Files
5	Data set
6	Setting The Connection
7	Data flow And Procedure
8	Debug In the Positioning
9	Print
10	Edit Function In data

5.4 Setting table information

5.4.1 The common items in table information.

Setting the table information at X, Y, XY-axis. Set the contents below for each axis.

→ For table information details, refer to the FX3U-20SSC-H user's manual.

1. The number of table information available for X, Y, XY-axis is as follows.

	Table information	The available table information number
Independent operation	X-axis table information	300
	Y-axis table information	300
Simultaneous operation at XY-axis	XY-axis table information	300

2. Items of each operation information for table information

✓: Available –: Not available

Operation info	Available axis	Address	Speed	Arc center	Arc radius	Wait time	Jump destination	m code
Positioning at 1-step speed*1	X, Y, XY-axis	✓	✓	–	–	–	–	✓
Interrupt stop at 1-step speed*1	X, Y, XY-axis	✓	✓	–	–	–	–	✓
Positioning at 2-step speed*1*2	X, Y, XY-axis	✓	✓	–	–	–	–	✓
Positioning at 2-step speed (Paired line)*1*2	X, Y, XY-axis	✓	✓	–	–	–	–	–
Interrupt stop at 2-step speed*1*2	X, Y, XY-axis	✓	✓	–	–	–	–	✓
Interrupt stop at 2-step speed (Paired line)*1*2	X, Y, XY-axis	–	✓	–	–	–	–	–
Interrupt stop*1	X, Y, XY-axis	✓	✓	–	–	–	–	✓
Operation at multi-step speed*1	X, Y, XY-axis	✓	✓	–	–	–	–	✓
Linear interpolation	XY-axis	✓	✓*3	–	–	–	–	✓
Linear interpolation (interrupt)	XY-axis	✓	✓*3	–	–	–	–	✓
Circular interpolation (CNT,CW)	XY-axis	✓	✓*3	✓	–	–	–	✓
Circular interpolation (CNT,CCW)	XY-axis	✓	✓*3	✓	–	–	–	✓
Circular interpolation (RAD,CW)	XY-axis	✓	✓*3	–	✓	–	–	✓
Circular interpolation (RAD,CCW)	XY-axis	✓	✓*3	–	✓	–	–	✓
Machine zero return*1	X, Y, XY-axis	–	–	–	–	–	–	✓
Present address changing*1	X, Y, XY-axis	✓	–	–	–	–	–	✓
Absolute address specification	X, Y, XY-axis	–	–	–	–	–	–	✓
Incremental address specification	X, Y, XY-axis	–	–	–	–	–	–	✓
Dwell	X, Y, XY-axis	–	–	–	–	✓	–	✓
Jump	X, Y, XY-axis	–	–	–	–	–	✓	–
m code	X, Y, XY-axis	–	–	–	–	–	–	✓
No processing	X, Y, XY-axis	–	–	–	–	–	–	–
End	X, Y, XY-axis	–	–	–	–	–	–	–

*1. XY-axis table information also sets X-axis and Y-axis independently.

*2. [Positioning at 2-step speed] and [Interrupt stop at 2-step speed] occupy 2 lines in table information.

*3. Available at X-axis only.

When selecting the items only for X-axis or Y-axis at the operation information in the XY-axis table information, the items for the other axis are not available.

5.4.2 Setting X/Y-axis table information

Setting X/Y-axis table information

- 1 Double-click [File name] → [Edit] → [X-axis table information] or [Y-axis table information] in the file data list.

The selected X or Y-axis table information edit window appears.

- 2 Set each item for the table information.

To enter texts and select items, double-click the cell.

→ For table information details, refer to FX3U-20SSC-H User's Manual.

No.	Command code	Address [PLS]	Speed [Hz]	Time [10ms]	Jump No.	m code
0	Positioning at 1-step speed	10000	50000000			-1
1	Positioning at 1-step speed	20000	50000000			-1
2	Positioning at 1-step speed	30000	50000000			-1
3	Positioning at 1-step speed	40000	50000000			-1
4	Positioning at 1-step speed	0	1			-1
5	Positioning at 1-step speed	0	1			-1
6	Dwell			100		-1
7	Positioning at 1-step speed	10000	50000000			-1

This window displays [X-axis table information] edit window.

Item	Description	Note
No.	Table information number	→ Refer to Subsection 5.4.1
Command code	Sets command code	
Address [PLS]	Sets the address. Setting range : -2,147,483,648~2,147,483,647 [User unit]*1 Set the value within -2,147,483,648~2,147,483,647PLS in the converted pulse data.	[User unit] varies depending on positioning parameters. → Refer to Section 5.2
Speed [Hz]	Sets the operation speed. Set the speed at or below the maximum rotation speed*2 of servo motor. Setting range : 1~Maximum speed [User unit]*1 Set the value within 1~50,000,000Hz in the converted pulse data.	
Time [10ms]	Sets the wait time. Setting range : 0~32767×10ms	
Jump No.	Sets the jump No. Setting range : 0~299	
m code	Sets the m code. Setting range : -1~32767*3	

*1. For the user unit and the converted pulse data, refer to the following.

→ Refer to Section 5.1.

*2. For the servo motor rotation speed and the operation speed (converted pulse data), refer to the following.

→ Refer to Subsection. 5.1.3

*3. When the operation information is m code, the setting range is 0~32767.

5.4.3 Setting XY-axis table information

Setting XY-axis table information.

- 1 Double-click [File name] → [Edit] → [XY-axis table information] in the file data list.

XY-axis table information edit window appears.

- 2 Set each item for the table information.

To enter texts and select items, double-click the cell.

→ For table information details, refer to FX3U-20SSC-H User's Manual.

No.	Command code	Address x: [PLS] y: [PLS]	Speed fx: [Hz] fy: [Hz]	Arc center i: [PLS] j: [PLS]	Arc radius r: [PLS]	Time [10ms]	Jump No.	m code
0	XY-axis positioning at 1-step speed	x: 0 y: 0	fx: 50000000 fy: 50000000					-1
1	XY-axis positioning at 1-step speed	x: 0 y: 0	fx: 50000000 fy: 50000000					-1
2	XY-axis positioning at 1-step speed	x: 0 y: 0	fx: 50000000 fy: 50000000					-1
3	XY-axis positioning at 1-step speed	x: 0 y: 0	fx: 50000000 fy: 50000000					-1
4	XY-axis positioning at 1-step speed	x: 0 y: 0	fx: 50000000 fy: 50000000					-1
5	Dwell					80		-1

Item	Description	Note
No.	Table information number	→ Refer to Subsection 5.4.1
Command code	Sets command code	
Address x: [PLS] (Upper) y: [PLS] (Lower)	Sets the address. Setting range : -2,147,483,648~2,147,483,647 [User unit]*1 Set the value within -2,147,483,648~2,147,483,647PLS in the converted pulse data.	
Speed fx: [Hz] (Upper) fy: [Hz] (Lower)	Sets the operation speed. Set the speed at or below the maximum rotation speed*2 of servo motor. Setting range : 1 ~ Maximum speed [User unit]*1 Set the value within 1~50,000,000Hz in the converted pulse data.	[User unit] varies depending on positioning parameters. → Refer to Section 5.2
Arc center i: [PLS] (Upper) j: [PLS] (Lower)	Sets the arc center. Setting range : -2,147,483,648~2,147,483,647 [User unit]*1 Set the value within -2,147,483,648~2,147,483,647PLS in the converted pulse data.	
Arc radius r: [PLS]	Sets the arc radius. Setting range : -2,147,483,648~2,147,483,647 [User unit]*1 Set the value within -2,147,483,648~2,147,483,647PLS in the converted pulse data.	
Time [10ms]	Sets the wait time. Setting range : 0~32767×10ms	
Jump No.	Sets the jump No. Setting range : 0~299	
m code	Sets the m code. Setting range : -1~32767*3	

*1. For the user unit and the converted pulse data, refer to the following.

→ Refer to Section 5.1.

*2. For the servo motor rotation speed and the operation speed (converted pulse data), refer to the following.

→ Refer to Subsection. 5.1.3

*3. When the operation information is m code, the setting range is 0~32767.

5.5 Error check

Checking the consistency and the incomplete settings in positioning parameters, servo parameters and table information.

1 Select [Tool] → [Error check].

Error check dialog box appears.

2 Select the item to be checked.

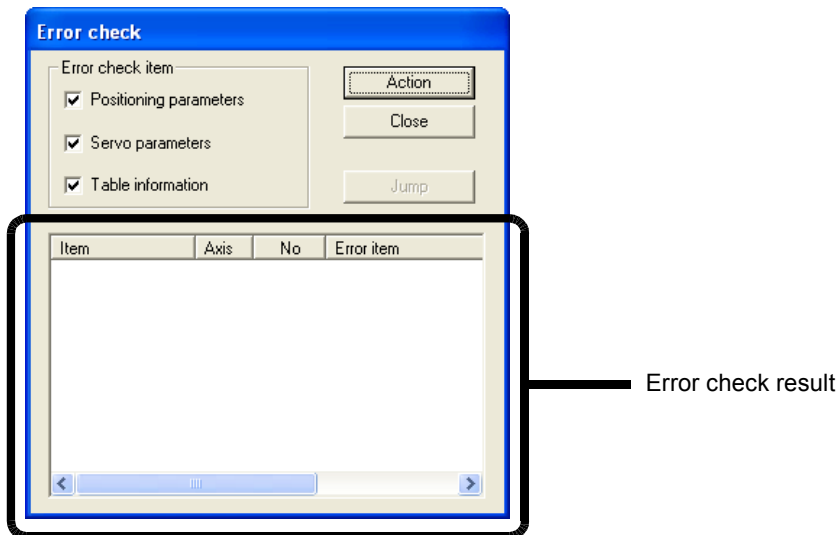

Item	Description
Error check items	Select the item targeted for Error check
Positioning parameters	Checks the positioning parameters when ticked off here
Servo parameters	Checks the servo parameters when ticked off here
Table information	Checks the table information when ticked off here
Error check result	Displays the items, axis, No. and error items after the error check
Item	Displays the positioning parameter, servo parameter or table information with errors
Axis	Displays X, Y, XY-axis with errors
No.	Displays the table information No. with errors It is blank here when any error in the positioning parameter or servo parameter
Error items	Displays the details of the error items
<Action>	Executes [Error check]
<Close>	Closes the dialog box
<Jump>	Displays the selected error location Enabled only with error detection

3 Click <Action>.

The error check result of the selected item appears.

1	Introduction
2	Install Uninstall Start&Exit
3	Window and Operation Config
4	Creating Files
5	Data set
6	Setting The Connection
7	Data flow And Procedure
8	Debug In the Positioning
9	Print
10	Edit Function In data

6. Setting the connection destination

Setting the connection destination (COM port, transmission speed and the 20SSC-H module No.).

Cautions on communication

- When connecting the personal computer interfaces to the same COM port in FX Configurator-FP and GX Developer, set the same baud rate for both. When FX Configurator-FP and GX Developer are running simultaneously, the baud rate that was set first has priority.
- An error may occur in the communication with FX PLC when used with the resume function, suspend setting, power-saving function and standby mode of the peripheral device. For this reason, do not set the functions above when communicating with the 20SSC-H.
- A communication error may occur depending on the combination of the personal computer model, USB cable and so on. In that case, refer to the message displayed and perform the operation again.
- When the baud rate changes for the fast communication at the serial port of the personal computer, it may disable the communication, or communication may delay due to too many retries depending on the personal computer spec. When the fast communication is not enabled, reduce the baud rate and restart communication.

1 Select [Online] → [Connection setup].

Connection setup dialog box appears.

2 Set each item.

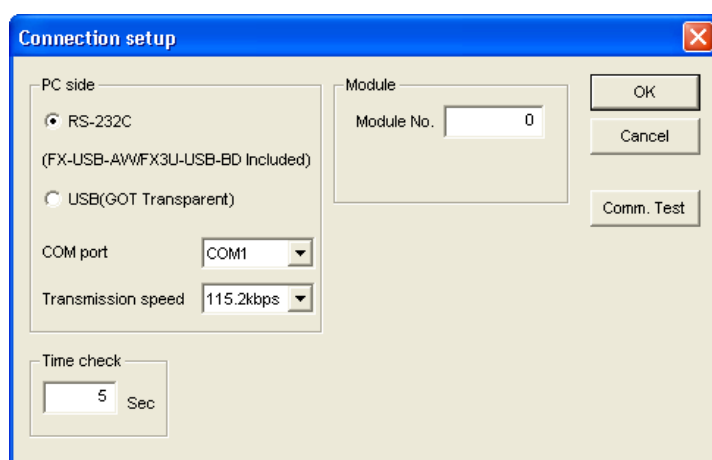

Item	Description	Default setting
PC side	Sets the COM port and transmission speed at PC side.	
PC side	Selects the personal computer to PLC connection method. (Ver.1.30 or later) <ul style="list-style-type: none"> • RS-232C: Select this connection method when connecting via RS-232C, RS-422, or USB (FX-USB-AW / FX3U-USB-BD only). • USB (GOT transparent): Select this connection method when connecting via the GOT1000 USB transparent mode. 	RS-232C
COM port	Sets the COM port at PC side. Setting range: COM1 to 10	COM1
Transmission speed	Sets the transmission speed. Setting range: 9.6kbps to 115.2kbps	115.2kbps

Item	Description	Default setting
Module	Sets the module No. for 20SSC-H.	
Module No.	Sets the module No. for 20SSC-H. Setting range: 0 to 7	0
Time check	Sets the timeout determination time. Unit: second Setting range: 1 to 9999 seconds	5 seconds
<Comm. Test>	Executes the communication test.	

Displayed messages

The message below appears depending on the communication setting.

Displayed Message	Description
Cannot communicate with the PLC. Execute again after checking the connections with the PLC. <ES: Error code>	A communication error has occurred. Check the connection with PLC, and the communication settings at the destination.
The connected PLC does not support this function. Please execute again after confirming the version of the PLC.	The connected PLC is not supported. Confirm the version of the PLC.
The module which supported this function is not found. Please execute again after confirming the module.	The special function block with assigned module No. is not 20SSC-H. Confirm the module No. and the connection between PLC and 20SSC-H.
Don't change connection data while online.	User has selected [Connection setup] menu while monitoring. (displaying operation monitor or the table information edit window for monitoring). Select [Connection setup] menu after disrupting the monitoring.
Module No. is range over.	User set the value outside the module No. range. Confirm the module No.
Time check is range over.	User set the value outside the time check range. Confirm the time check setting.

1

Introduction

2

Install
Uninstall
Start&Exit

3

Window and
Operation
Config

4

Creating
Files

5

Data set

6

Setting
The
Connection

7

Data flow
And
Procedure

8

Debug
In the
Positioning

9

Print

10

Edit
Function
In data

7. Read / Write / Verify / Initialize

Reading, Writing and Verifying the data (positioning parameters, servo parameters and table information) for each axis, and initializing the 20SSC-H.

Caution

When reading or writing data, use the FX Configurator-FP version that is the same as or later than the FX Configurator-FP used to write data to the 20SSC-H.

Using FX Configurator-FP of earlier version may clear the setting data or change the setting data to invalid values.

7.1 Data type and storage location

1. Data type and Description

Data type	Description	Storage location
Positioning parameters	<p>The parameters required for positioning control. → For positioning parameters details, Refer to FX3U-20SSC-H User's manual. → For setting procedures of positioning parameters, refer to Section 5.2.</p> <ul style="list-style-type: none"> Positioning parameters for X-axis. Positioning parameters for Y-axis 	<ul style="list-style-type: none"> The BFM in 20SSC-H Flash ROM in 20SSC-H
Servo parameters	<p>The parameters of servo amp. 20SSC-H transfers servo parameters to servo amps via SSCNET III at power on. → For servo parameters details, refer to the manual of the servo amp to be used. → For setting procedures of servo parameters, refer to Section 5.3.</p> <ul style="list-style-type: none"> Servo parameters for X-axis. Servo parameters for Y-axis 	<ul style="list-style-type: none"> The BFM in 20SSC-H Flash ROM in 20SSC-H
Table information	<p>The data for table operation.</p> <ul style="list-style-type: none"> Table information for X-axis. Table information for Y-axis. Table information for XY-axis. 	<ul style="list-style-type: none"> The BFM in 20SSC-H Flash ROM in 20SSC-H

2. Data flow

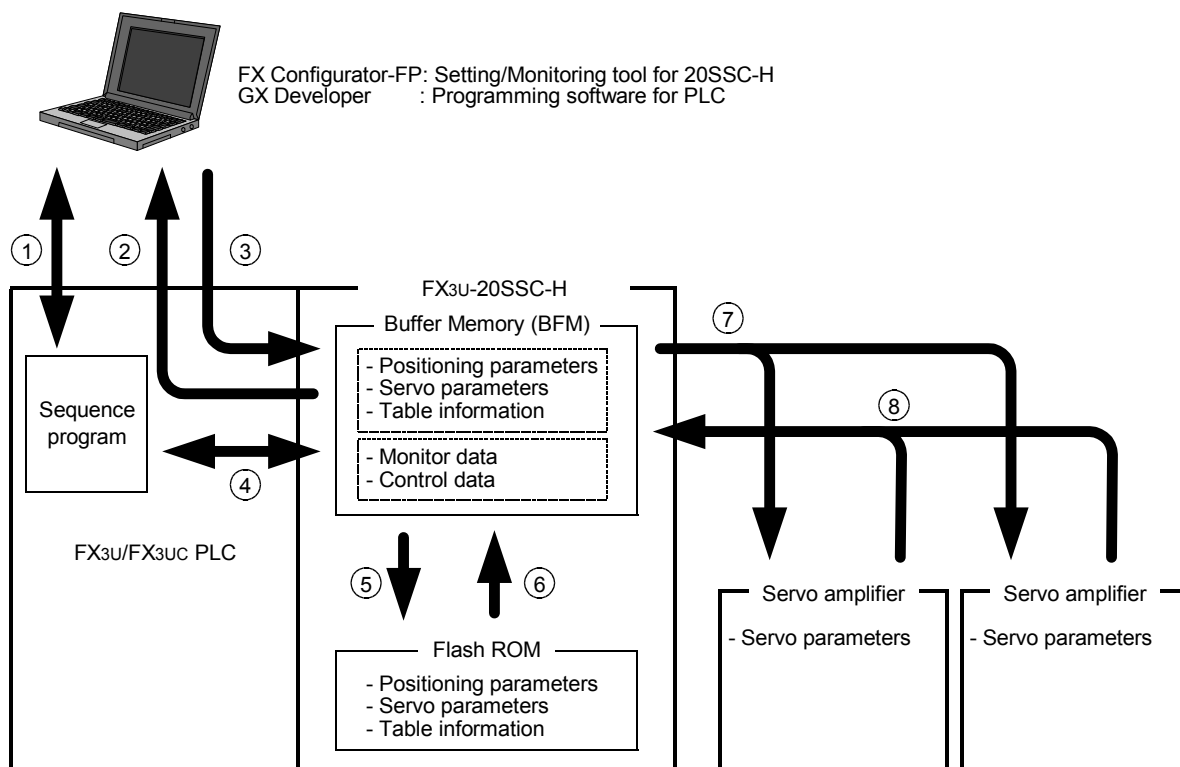

No.	Description
①	Read/Write/Monitor/Test the sequence programs with GX Developer.
②	Read out the following data from the 20SSC-H BFM to FX Configurator-FP. <ul style="list-style-type: none"> • Positioning parameters • Servo parameters • Table information • Monitor data (Operation status, motion status and input signal status, etc.)
③	Write the following data from FX Configurator-FP to the 20SSC-H BFM. <ul style="list-style-type: none"> • Positioning parameters • Servo parameters • Table information • Control data (The present value change, speed change and operation test command, etc.)
④	Read/Write the following data in BFM with sequence program. <ul style="list-style-type: none"> • Positioning parameters • Servo parameters • Table information • Monitor data (Operation status, motion status and input signal status, etc.) • Control data (The present value change, speed change and operation test command, etc.)
⑤	Store the following BFM data to the Flash ROM by the store command from the sequence program or FX Configurator-FP. <ul style="list-style-type: none"> • Positioning parameters • Servo parameters • Table information
⑥	Positioning/servo parameters and table information transfer from the Flash ROM to the BFM in 20SSC-H at power ON, simultaneously servo parameters transfer to servo amps.
⑦	Servo parameters transfer to servo amps at power ON. → For transfer procedure, refer to the next page.
⑧	20SSC-H retrieves servo parameters changed at servo amp sides, and updates the servo parameters in its BFM.

How to transfer (write) servo parameters to servo amplifiers

When the power is turned ON or when the system is reset*¹, servo parameters stored in the flash ROM are transferred to the buffer memory. After that, when the servo series (BFM #15000 and #15200) are set to the corresponding values for the connected servo amplifiers, servo parameters are transferred from the buffer memory to the servo amplifiers.

The following two transfer methods are available:

- Method to transfer servo parameters stored in the flash ROM to the servo amplifiers
- Method to transfer servo parameters set in the sequence program to the servo amplifiers (Available in 20SSC-H Ver. 1.10 or later)

*1. System reset is supported in FX3U-20SSC-H Ver. 1.10 or later.

→ **Refer to the FX3U-20SSC-H User's Manual for more details on transfer methods and system reset.**

Note

When turning OFF and then ON the servo parameter transfer command [BFM #519 b9 (X-axis), #619 b9 (Y-axis)], the following parameters in BFM transfer to servo amps.

- 1) Servo parameters to be transferred.
 - Auto tuning
 - Auto tuning response
 - Feed forward gain
 - Ratio of load inertia moment to servo motor inertia moment.
 - Model loop gain
 - Position loop gain
 - Speed loop gain
 - Speed integral compensation
 - Speed differential compensation
- 2) The execution condition of the servo parameter transfer command [BFM #519 b9 (X-axis), #619 b9 (Y-axis)] 20SSC-H ignores the servo parameter transfer command during positioning motion.
- 3) Servo parameters in transmission [BFM #28 b10 (X-axis), #128 b10 (Y-axis)] [Servo parameters in transmission] in status information turns ON during servo parameters in transmission.

→ **For details, refer to the FX3U-20SSC-H User's Manual.**

7.2 Reading [positioning/servo parameters and table information]

Reading [positioning/servo parameters and table information] from the 20SSC-H BFM.

1 Operate any of the following procedures

- Click  [Read from module].
- Select [Online] → [Read from module].

[Read from module] dialog box appears.

2 Select the data to be read.

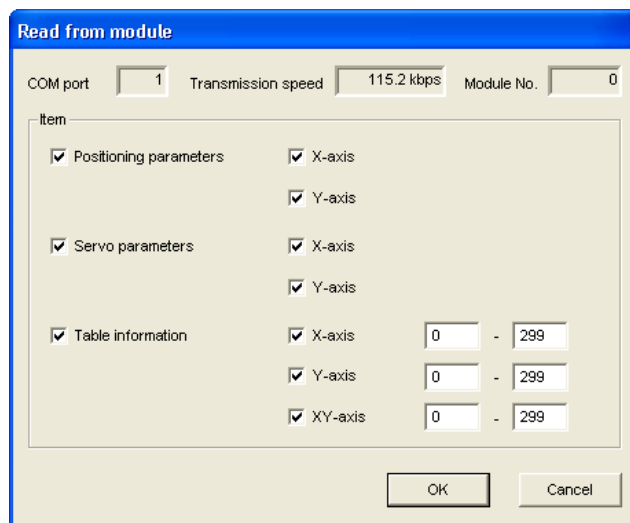

Item	Description
COM port	Displays [COM port] in [Connection setup] dialog box
Transmission speed	Displays [Transmission speed] in [Connection setup] dialog box
Module No.	Displays [Module No.] in [Connection setup] dialog box
Item	Ticks off the data to be read
Positioning parameters	Ticks off the axis of positioning parameters to be read <ul style="list-style-type: none"> • X-axis • Y-axis
Servo parameters	Ticks off the axis of servo parameters to be read <ul style="list-style-type: none"> • X-axis • Y-axis
Table information	Sets the reading range after ticking off the axis of table information to be read Setting range : 0 to 299 <ul style="list-style-type: none"> • X-axis • Y-axis • XY-axis
<OK>	Reads the selected data from the BFM
<Cancel>	Cancels selecting and closes the dialog box

3 Click <OK>.

FX Configurator-FP reads out the selected data from the 20SSC-H BFM.

→ For the displayed messages, refer to Section 7.6.

7.3 Writing [positioning/servo parameters and table information]

Data writing procedures comprise of [Write to module] and [Flash ROM write].

7.3.1 Writing to the BFM

Writing [positioning parameters, servo parameters table information] to the 20SSC-H BFM.

1 Operate any of the following procedures

- Click  [Write to module].
- Select [Online] → [Write to module].

[Write to module] dialog box appears.

2 Select the data to be written.

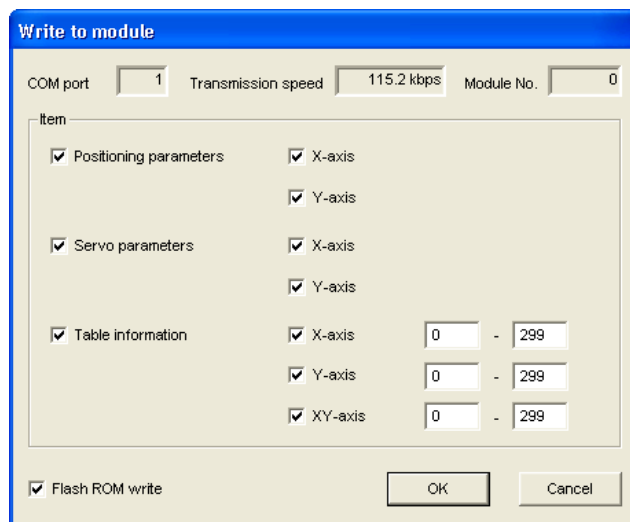

Item	Description
COM port	Displays [COM port] in [Connection setup] dialog box
Transmission speed	Displays [Transmission speed] in [Connection setup] dialog box
Module No.	Displays [Module No.] in [Connection setup] dialog box
Item	Ticks off the data to be read
Positioning parameters	Ticks off the axis of positioning parameters to be written <ul style="list-style-type: none"> • X-axis • Y-axis
Servo parameters	Ticks off the axis of servo parameters to be written <ul style="list-style-type: none"> • X-axis • Y-axis
Table information	Sets the writing range after ticking off the axis of table information to be written Setting range : 0 to 299 <ul style="list-style-type: none"> • X-axis • Y-axis • XY-axis
Flash ROM write*1	Ticks off when writing the data selected in [Item] to Flash ROM
<OK>	Writes the selected data to the BFM
<Cancel>	Cancels selecting and closes the dialog box

*1. For the flash ROM write, refer to the following.

→ For the flash ROM write, refer to Subsection 7.3.2.

3 Click <OK>.

FX Configurator-FP writes the selected data to the 20SSC-H BFM.

→ For the displayed messages, refer to Section 7.6.

7.3.2 Writing to the Flash ROM

Storing [positioning parameters, servo parameters and table information written beforehand in the 20SSC-H BFM] in the Flash ROM. After setting up and adjusting the system, it is handy when storing [positioning parameters, servo parameters and table information] in the BFM.

1 Select [Online] → [Flash ROM write].

[Flash ROM write (BFM -> Flash ROM)] appears.

2 Select the data to be stored in the Flash ROM.

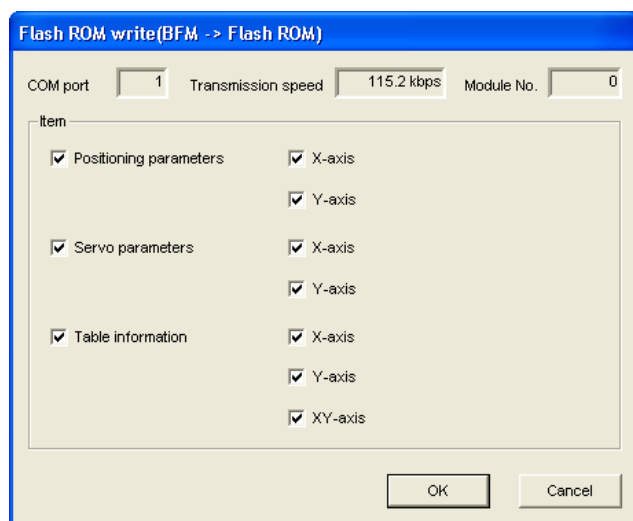

Item	Description
COM port	Displays [COM port] in [Connection setup] dialog box
Transmission speed	Displays [Transmission speed] in [Connection setup] dialog box
Module No.	Displays [Module No.] in [Connection setup] dialog box
Item	Ticks off the data to be stored
Positioning parameters	Ticks off the axis of positioning parameters to be stored <ul style="list-style-type: none"> • X-axis • Y-axis
Servo parameters	Ticks off the axis of servo parameters to be stored <ul style="list-style-type: none"> • X-axis • Y-axis
Table information	Ticks off the axis of table information to be stored <ul style="list-style-type: none"> • X-axis • Y-axis • XY-axis
<OK>	Store the selected data in the BFM
<Cancel>	Cancels selecting and closes the dialog box

3 Click <OK>.

FX Configurator-FP stores the selected 20SSC-H BFM data in the Flash ROM.

Caution

While data on the X- or Y-axis cannot be written, data on both the X- and Y-axes cannot be written to the flash ROM.

Wait until data on both the X- and Y-axes can be written, and then write data to the flash ROM.

7.4 Verifying [positioning parameters, servo parameters table information]

Verifying the following FX Configurator-FP data with the 20SSC-H BFM.

- Positioning parameters
- Servo parameters
- Table information

1 Operate any of the following procedures

- Click  [Verify module data].
- Select [Online] → [Verify module data].

[Verify module data] dialog box appears.

2 Select the data to be verified.

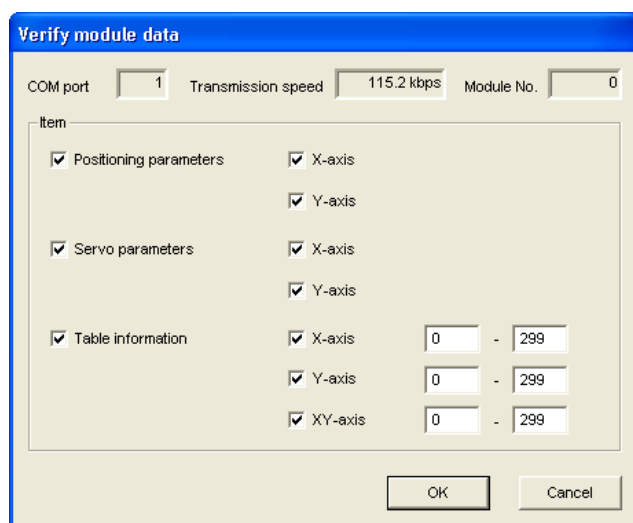

Item	Description
COM port	Displays [COM port] in [Connection setup] dialog box
Transmission speed	Displays [Transmission speed] in [Connection setup] dialog box
Module No.	Displays [Module No.] in [Connection setup] dialog box
Item	Ticks off the data to be verified
Positioning parameters	Ticks off the axis of positioning parameters to be verified <ul style="list-style-type: none"> • X-axis • Y-axis
Servo parameters	Ticks off the axis of servo parameters to be verified <ul style="list-style-type: none"> • X-axis • Y-axis
Table information	Sets the verifying range after ticking off the axis of table information to be verified Setting range : 0 to 299 <ul style="list-style-type: none"> • X-axis • Y-axis • XY-axis
<OK>	verifies the selected data by FX Configurator-FP and the BFM
<Cancel>	Cancels selecting and closes the dialog box

3 Click <OK>.

The verification result of selected data appears.

When the verification result agrees.

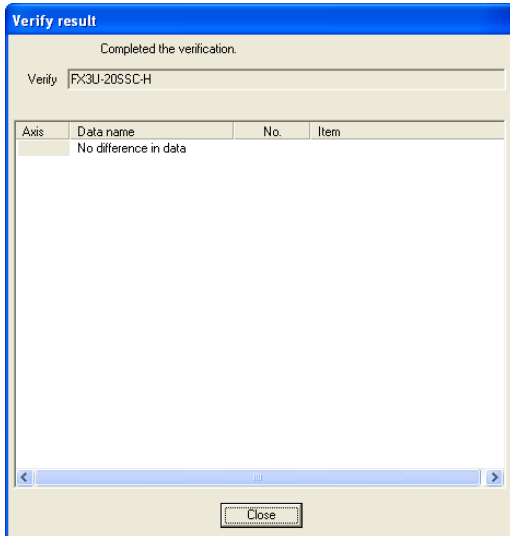

When the verification result disagrees.

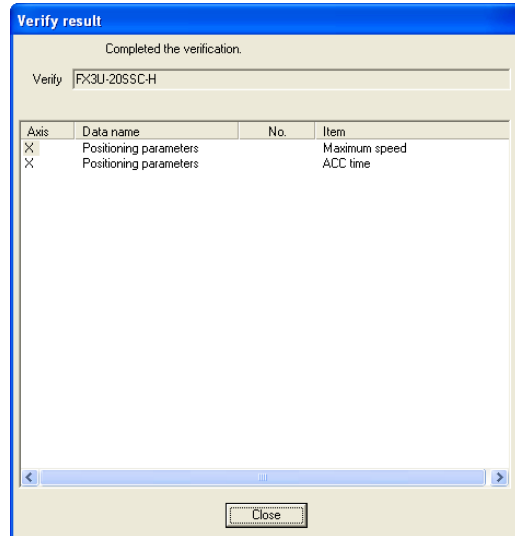

Item	Description
Verify	Displays the special function unit/block name of verifying destination
Verification result	Displays the item, axis, No. and error item when completing the verification
Axis	Displays the disagreed axis by X, Y or XY
Data name	Displays the positioning parameter, servo parameter or table information as a disagreed data name
No.	Displays the disagreed table information No. It is blank here when any disagreement in positioning parameters and servo parameters
Item	Displays the details of the disagreed positioning parameter, servo parameter or table information
<Close>	Closes the dialog box

- 1 Introduction
- 2 Install
Uninstall
Start&Exit
- 3 Window and
Operation
Config
- 4 Creating
Files
- 5 Data set
- 6 Setting
The
Connection
- 7 Data flow
And
Procedure
- 8 Debug
In the
Positioning
- 9 Print
- 10 Edit
Function
In data

7.5 Initializing the BFM and Flash ROM

Initializing [positioning parameters, servo parameters and table information] in the 20SSC-H BFM and Flash ROM.

1 Select [Online] → [Initialize module].

[Initialize module] dialog box appears.

2 Select the data to be initialized.

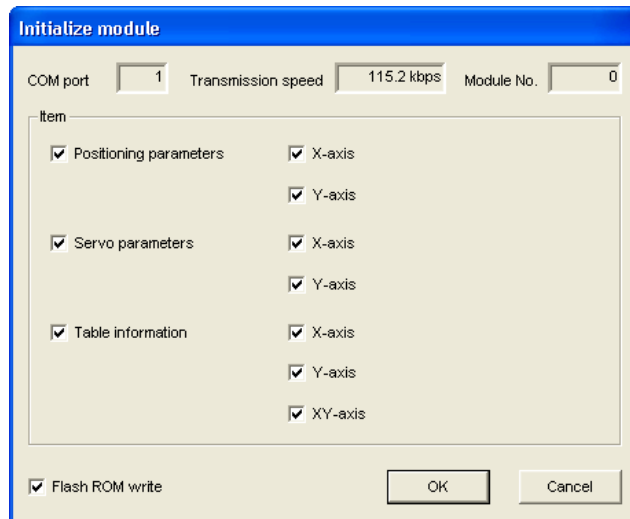

Item	Description
COM port	Displays [COM port] in [Connection setup] dialog box
Transmission speed	Displays [Transmission speed] in [Connection setup] dialog box
Module No.	Displays [Module No.] in [Connection setup] dialog box
Item	Ticks off the data to be initialized
Positioning parameters	Ticks off the axis of positioning parameters to be initialized <ul style="list-style-type: none"> • X-axis • Y-axis
Servo parameters	Ticks off the axis of servo parameters to be initialized <ul style="list-style-type: none"> • X-axis • Y-axis
Table information	Ticks off the axis of table information to be initialized <ul style="list-style-type: none"> • X-axis • Y-axis • XY-axis
Flash ROM write	Ticks off when initializing the Flash ROM data selected in [Item]
<OK>	Initializes the selected data
<Cancel>	Cancels selecting and closes the dialog box

3 Click <OK>.

FX Configurator-FP initializes the selected data in the 20SSC-H BFM.

→ For the displayed messages, refer to Section 7.6.

Caution

While data on the X- or Y-axis cannot be initialized, data on both the X- and Y-axes stored in the unit cannot be initialized.

Wait until data on both the X- and Y-axes can be initialized, and then initialize the unit.

7.6 Execute system reset of the 20SSC-H

→ For more details on system reset details, Refer to the FX3U-20SSC-H User's manual.

1 Operate any of the following procedures

- Click  [System reset].
- Select [Online] → [System reset].

Executing system reset displays the following message.

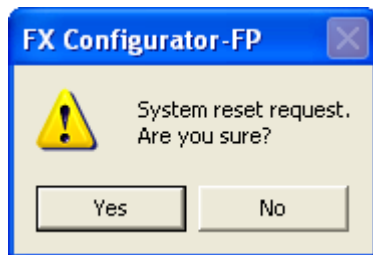

- Click <Yes> to execute system reset.
- Click <No> to cancel the operation.

7.7 Sets the servo parameter update stop

Sets the servo parameter update stop valid/invalid at X/Y-axis.

→ For more details on servo parameter update stop details, Refer to the FX3U-20SSC-H User's manual.

1 Select [Online] → [Servo parameter update stop].

Servo parameter update stop dialog box appears.

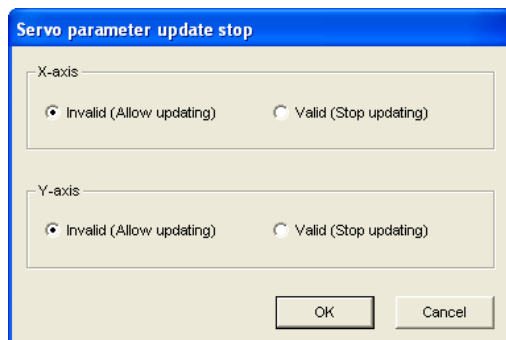

Item	Description
Servo parameter update stop	Sets the servo parameter update stop valid/invalid at X/Y-axis. • X-axis : Invalid (Allow updating) / Valid (Stop updating) • Y-axis : Invalid (Allow updating) / Valid (Stop updating)
<OK>	Changes the servo parameter update stop
<Cancel>	Cancels selecting and closes the dialog box

2 Click <OK>.

The setting of servo parameter update stop is changed to "valid" or "invalid".

7.8 The displayed messages and countermeasures

This section explains the countermeasures for error messages.

Displayed Message	Description
Cannot communicate with the PLC. Execute again after checking the connections with the PLC. <ES: Error code>	A communication error has occurred. Check the connection with PLC, and the communication settings at the destination.
The connected PLC dose not support this function. Please execute again after confirming the version of the PLC.	The connected PLC is not supported. Confirm the version of the PLC.
The module which supported this function is not found. Please execute again after confirming the module.	The special function block with assigned module No. is not 20SSC-H. Confirm the module No. and the connection between PLC and 20SSC-H.
It is range over. Check that the value is correct, and execute again.	It is range over.
Because data disagreement has exceeded 100 items, the verify processing is interrupted.	The disagreement in verification has exceeded 100.

8. Debug in the positioning

DESIGN PRECAUTIONS	 DANGER
<ul style="list-style-type: none"> • Provide a safety circuit on the outside of the PLC so that the whole system operates to ensure the safety even when external power supply trouble or PLC failure occurs. Otherwise, malfunctions or output failures may result in an accident. <ol style="list-style-type: none"> 1) An emergency stop circuit, a protection circuit, an interlock circuit for opposite movements, such as normal and reverse rotations, and an interlock circuit for preventing damage to the machine at the upper and lower positioning limits should be configured on the outside of the PLC. 2) When the PLC CPU detects an error, such as a watch dog timer error, during self-diagnosis, all outputs are turned off. When an error that cannot be detected by the PLC CPU occurs in an input/output control block, output control may be disabled. Design external circuits and mechanisms to ensure safe operations of the machine in such a case. 3) When some sort of error occurs in a relay, triac or transistor of the output unit, output may be kept on or off. For output signals that may lead to serious accidents, design external circuits and mechanisms to ensure safe operations of the machine in such cases. 	

DESIGN PRECAUTIONS	 CAUTION
<ul style="list-style-type: none"> • Observe the following items. Failure to do so may cause incorrect data-writing by noise to PLCs and result the PLC failure, machine damage or an accident. <ol style="list-style-type: none"> 1) Do not lay close or bundle with the main circuit line, high-voltage line, or load line. Noise and Surge induction interfere with the system operation. Keep a safe distance of least 100 mm (3.94") from the above lines during wiring. 2) Ground the shield wire or shield of a shielded cable at one point on the PLC. However, do not ground at the same point as high voltage lines. • Install in a manner which prevents excessive force from being applied to the built-in connectors dedicated to programming, power connectors and I/O connectors. Failure to do so may result in wire breakage or failure of the PLC. 	

INSTALLATION PRECAUTIONS	 DANGER
<ul style="list-style-type: none"> • Make sure to cut off all phases of the power supply externally before starting the installation or wiring work. Failure to do so may cause electric shock. 	

INSTALLATION PRECAUTIONS	 CAUTION
<ul style="list-style-type: none"> • Fit the extension cables, peripheral device connecting cables, input/output cables and battery connecting cable securely to the designated connectors. Contact failures may cause malfunctions. • Make sure to attach the terminal cover offered as an accessory to the product before turning on the power or starting the operation after installation or wiring work. Failure to do so may cause electric shock. 	

1	Introduction
2	Install Uninstall Start&Exit
3	Window and Operation Config
4	Creating Files
5	Data set
6	Setting The Connection
7	Data flow And Procedure
8	Debug In the Positioning
9	Print
10	Edit Function In data

**STARTUP AND MAINTENANCE
PRECAUTIONS**



- Do not touch any terminal while the PLC's power is on.
Doing so may cause electrical shock or malfunctions.
- Before cleaning or retightening terminals, externally cut off all phases of the power supply.
Failure to do so may expose you to shock hazard.
- Before modifying the program under operation or performing operation for forcible output, running or stopping, carefully read the manual, and sufficiently ensure the safety.
An operation error may damage the machine or cause accidents.
- To test Zero-return, JOG operation and Positioning data, thoroughly read this manual, ensure the safe system operation
An operation error may damage the machine or cause accidents.
The response, such as the JOG operation, may be slow according to the running state of the personal computer at the time of the test operation. In the test operation, the PLC performance can be slower due to the busy state of personal computer.
 - End all other applications running except FX Configurator-FP.
 - At destination specification (refer to chapter 6), set the transmission speed at 38.4kbps or higher.

**STARTUP AND MAINTENANCE
PRECAUTIONS**





- Do not disassemble or modify the PLC.
Doing so may cause failures, malfunctions or fire.
For repair, contact your local Mitsubishi Electric distributor.
- Before connecting or disconnecting any extension cable, turn off power.
Failure to do so may cause unit failure or malfunctions.
- Before attaching or detaching the following devices, turn off power.
Failure to do so may cause device failure or malfunctions.
 - Peripheral devices, expansion boards and special adapters
 - I/O extension blocks/units and terminal blocks

The monitors/tests debug the positioning operation.

Caution

When the communication error due to the forced termination of FX Configurator-FP, peripheral devices' power OFF and the connection cable unplugging occurs, all axis stops.

- 1) Operate any of the following procedures when turning OFF m code while monitoring/testing.
 - Click  [m code off X-axis] /  [m code off Y-axis].
 - Click [Online] → [Test] → [m code off] → [m code off X-axis] / [m code off Y-axis].
- 2) Operate any of the following procedures when suspending all axis in operation due to peripheral the devices' error, etc. while monitoring/testing.
 - Click  [All axis stop command].
 - Click [Online] → [Test] → [All axis stop].

8.1 Monitor

8.1.1 Monitoring the operation

Monitoring the operation status along each axis.

- 1 Double-click [File name] → [Monitor] → [Operation monitor] in the file data list.

[Operation monitor] dialog box appears.

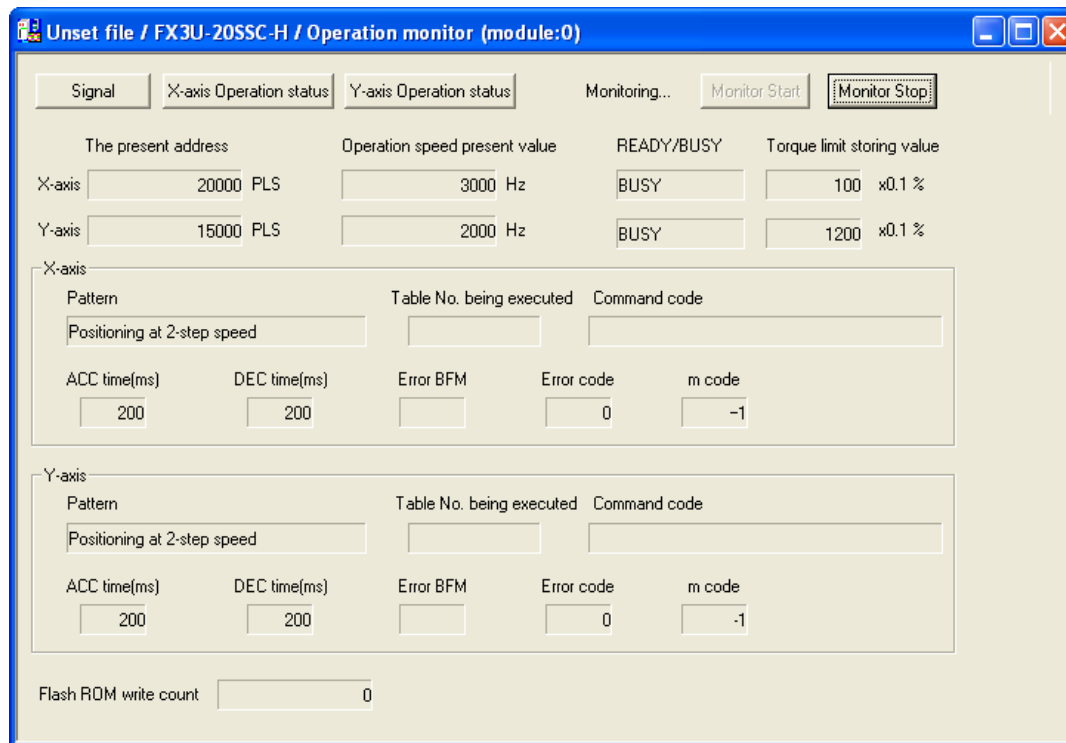

Item	Description
The present address	Displays the present address of X/Y-axis [Unit : User unit*1]
Operation speed present value	Displays the operation speed present value along X/Y-axis [Unit : User unit*1]
READY/BUSY	Displays READY/BUSY status along X/Y-axis <ul style="list-style-type: none"> • READY : Standby • BUSY : Active
Torque limit storing value	Displays the value stored in the X/Y-axis torque limit
Pattern	Displays the pattern along X/Y-axis
Table No. being executed	Displays the X/Y-axis table No. in execution It is blank here at other than table operation
Command code	Displays the X/Y-axis command code in table operation It is blank here at other than table operation
ACC time (ms)	Displays the ACC time set in the X/Y-axis positioning parameter
DEC time (ms)	Displays the DEC time set in the X/Y-axis positioning parameter
Error BFM	Displays the error BFM numbers along the X/Y-axis It is blank here with no error
Error code	Displays the X/Y-axis error code Displays 0 with no error
m code	Displays the X/Y-axis ON-state m code Displays -1 with no ON-state m code

1	Introduction
2	Install Uninstall Start&Exit
3	Window and Operation Config
4	Creating Files
5	Data set
6	Setting The Connection
7	Data flow And Procedure
8	Debug In the Positioning
9	Print
10	Edit Function In data

Item	Description
Flash ROM write count	Displays the writing count to Flash ROM
<Signal>	Opens the signal monitor window, available only while monitoring → For the signal monitor window, refer to Section 8.1.2
<X-axis Operation status>	Opens the X-axis Operation status monitor window, available only while monitoring → For the X-axis Operation status monitor window, refer to 8.1.3
<Y-axis Operation status>	Opens the Y-axis Operation status monitor window, available only while monitoring → For the Y-axis Operation status monitor window, refer to 8.1.3
Monitoring	Displays [Monitoring] when monitoring
<Monitor Start>	Starts operation monitor, validating [Signal], [X-axis Operation status], [Y-axis Operation status] and [Monitor Stop].
<Monitor Stop>	Stops the operation monitor, closing the signal, X/Y-axis operation status monitor widow

*1. For the user unit and the converted pulse data, refer to the following.

→ **Refer to Section 5.1.**

2 Click <Monitor Start>.

The operation monitor starts

8.1.2 Signal monitor

Monitoring the status information and servo status information.

1 Double-click [File name] → [Monitor] → [Operation monitor] → [Signal] in the file data list.

[Status signal] tab in [Signal] dialog box appears.

2 Click the status tab to be monitored.

- Click [Status signal] tab to display the status signal.
- Click [Servo status signal] tab to display the servo status signal.

1. Status signal tab

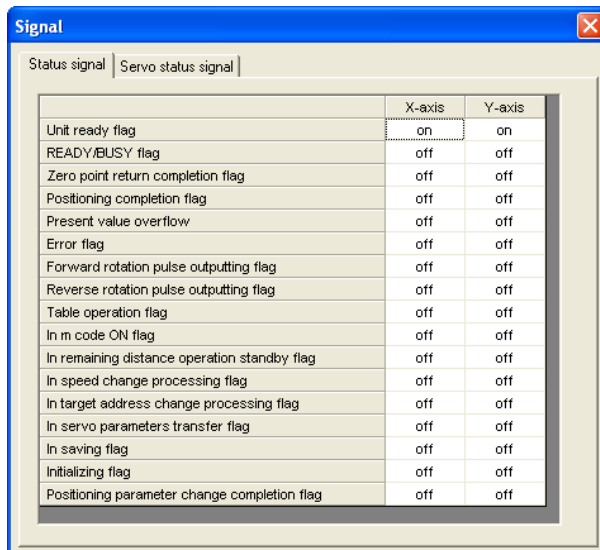

Item	Description
Unit ready flag	
READY/BUSY flag	
Zero point return completion flag	
Positioning completion flag	
Present value overflow	
Error flag	
Forward rotation pulse outputting flag	
Reverse rotation pulse outputting flag	Displays each flag status along X/Y-axis as follows on : ON off : OFF
Table operation flag	
In m code ON flag	
In remaining distance drive standby flag	
In speed change processing flag	
In target address change processing flag	
In servo parameter transfer flag	
In saving flag	
Initializing flag	
Positioning parameter change completion flag	

2. Servo status signal tab

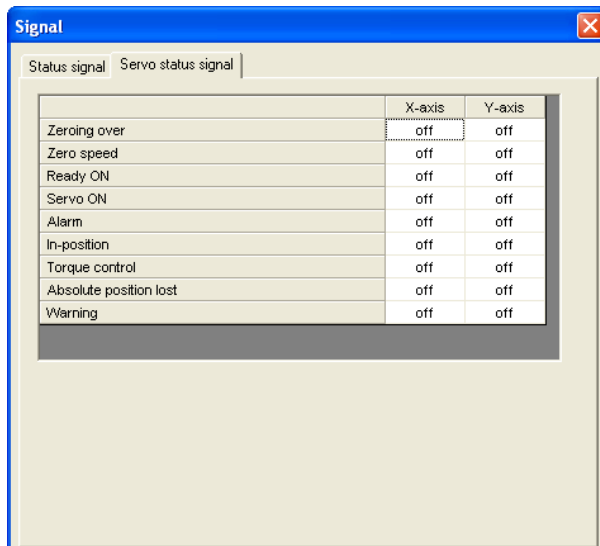

Item	Description
Zeroing over	Displays each flag status along X/Y-axis as follows on : ON off : OFF
Zero speed	
Ready ON	
Servo ON	
Alarm	
In-position	
Torque control	
Absolute position lost	
Warning	

1	Introduction
2	Install Uninstall Start&Exit
3	Window and Operation Config
4	Creating Files
5	Data set
6	Setting The Connection
7	Data flow And Procedure
8	Debug In the Positioning
9	Print
10	Edit Function In data

8.1.3 Operation status monitor

Monitoring the detailed operation status along X/Y-axis.

1 Double-click [File name] → [Monitor] → [Operation monitor] → [X-axis Operation status] / [Y-axis Operation status] in the file data list.

[Axis control data] tab in [X/Y-axis Operation status] dialog box appears.

2 Click the tab to be monitored.

- Click [Axis control data] tab to display the axis control data.
- Click [JOG/MPG] tab to display the JOG/MPG.
- Click [Servo monitor] to display the servo monitor

1. Axis control data tab

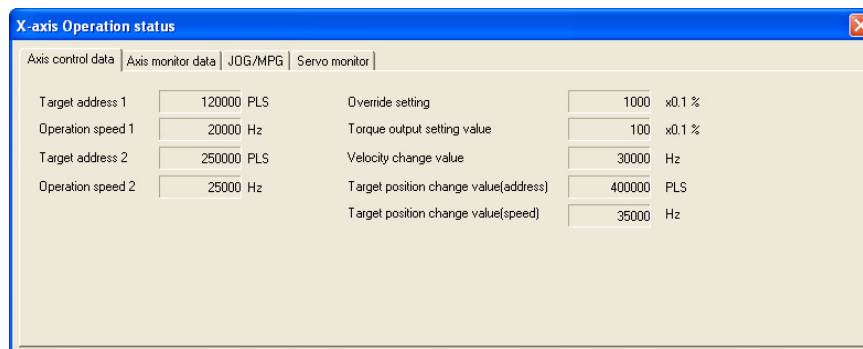

This window displays [X-axis Operation status] dialog box.

Item	Description	Note
Target address1	Displays target address1 [Unit : User unit]	→ For [user unit], refer to Section 5.1
Operation speed1	Displays operation speed1 [Unit : User unit]	
Target address2	Displays target address2 [Unit : User unit]	
Operation speed2	Displays operation speed2 [Unit : User unit]	
Override setting	Displays the override setting [Unit : 0.1%]	
Torque output setting value	Displays the torque output setting value [Unit : 0.1%]	
Velocity change value	Displays the Velocity change value [Unit : User unit]	→ For [user unit], refer to Section 5.1
Target position change value (address)	Displays Target position change value (address) [Unit : User unit]	
Target position change value (speed)	Displays Target position change value (speed) [Unit : User unit]	

2. Axis monitor data tab

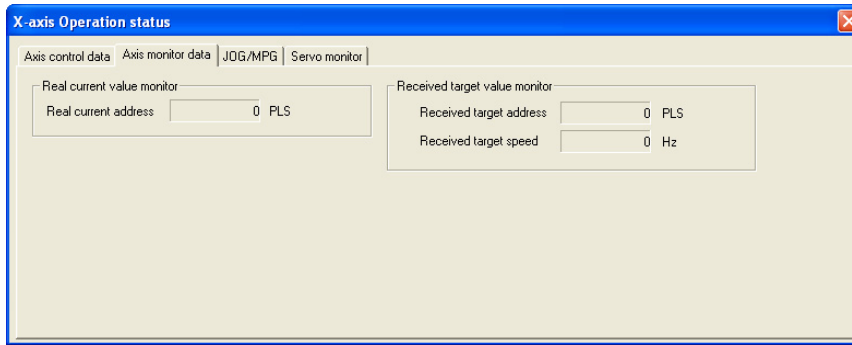

This window displays [X-axis Operation status] dialog box.

Item	Description
Real current value monitor	Displays the Real current value monitor
Real current address	Displays the Real current address [Unit : User unit* ¹]
Received target value monitor	Displays the Received target value monitor
Received target address	Displays the Received target address [Unit : User unit* ¹]
Received target speed	Displays the Received target speed [Unit : User unit* ¹]

*1. For user units and the converted pulse data, refer to the following.

→ Refer to Section 5.1.

3. JOG/MPG tab

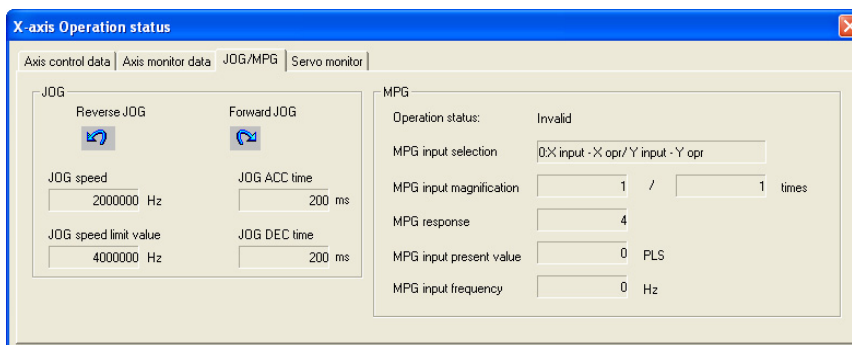

This window displays [X-axis Operation status] dialog box.

Item	Description
JOG	Displays the JOG monitor
Forward JOG,Reverse JOG	Displays the JOG rotation direction
JOG speed	Displays the JOG speed [Unit : User unit* ¹]
JOG ACC time	Displays the JOG ACC time [Unit : ms]
JOG speed limit value	Displays the JOG speed limit value [Unit : User unit* ¹]
JOG DEC time	Displays the JOG DEC time [Unit : ms]
MPG	Displays the MPG monitor
Operation status	Displays the Operation status
MPG input selection	Displays the MPG input selection
MPG input magnification	Displays the MPG input magnification
MPG response	Displays the MPG response
MPG input present value	Displays the MPG input present value [Unit : PLS]
MPG input frequency	Displays the MPG input frequency [Unit : Hz]

*1. For user units and the converted pulse data, refer to the following.

→ Refer to Section 5.1.

1	Introduction
2	Install Uninstall Start&Exit
3	Window and Operation Config
4	Creating Files
5	Data set
6	Setting The Connection
7	Data flow And Procedure
8	Debug In the Positioning
9	Print
10	Edit Function In data

4. Servo monitor tab

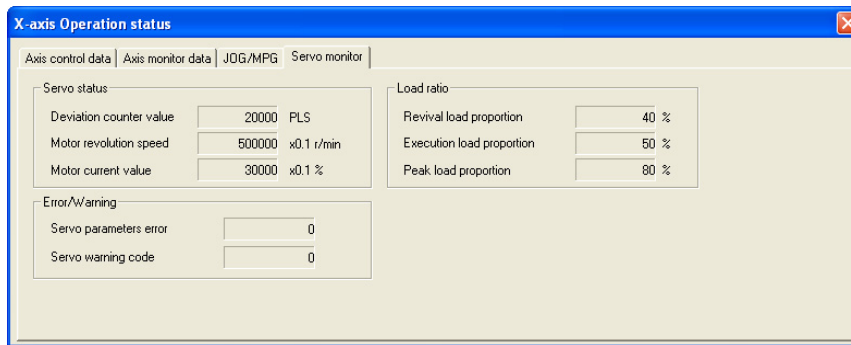

This window displays [X-axis Operation status] dialog box.

Item	Description
Servo status	Displays Servo status
Deviation counter value	Displays the deviation counter value [Unit : PLS]
Motor revolution number	Displays the motor revolution number [Unit : 0.1r/min]
Motor current value	Displays the motor current value [Unit : 0.1%]
Load ratio	
Revival load proportion	Displays the revival load proportion [Unit : %]
Execution load proportion	Displays the execution load proportion [Unit : %]
Peak load proportion	Displays the peak load proportion [Unit : %]
Error/Warning	
Servo parameter error	Displays the servo parameter error
Servo warning code	Displays the servo warning code

8.1.4 Monitoring table information

Monitoring the table information in execution, from the table information edit window.

Caution

Monitor mode doesn't allow each item to change. Change/set the value after switching the window into the edit mode.

1 Display the X-axis, Y-axis and XY-axis edit window.

→ To display the windows, refer to Section 5.4.

No.	Command code	Address [PLS]	Speed [Hz]	Time [10ms]	Jump No.	m code
0	Positioning at 1-step speed	10000	50000000			-1
1	Positioning at 1-step speed	20000	50000000			-1
2	Positioning at 1-step speed	30000	50000000			-1
3	Positioning at 1-step speed	40000	50000000			-1
4	Positioning at 1-step speed	400000	50000000			-1
5	Positioning at 1-step speed	500000	50000000			-1
6	Dwell			100		-1
7	Positioning at 1-step speed	50000	50000000			-1

This window displays [X-axis table information edit window].

2 Follow any of the procedures below.

- Click [Monitor On/Off].
- Select [Online] → [Monitor] → [Monitor On/Off].

X, Y, XY-axis table information edit window changes into monitor mode.

The items in table information edit window of each axis is the same as those in the table information edit window.

- X or Y-axis table information changes into monitor mode when operating from the X-axis table information or Y-axis table information edit window.
- Only XY-axis table information changes into monitor mode when operating from XY-axis table information edit window.

→ For table information edit windows, refer to Section 5.4.

No.	Command code	Address [PLS]	Speed [Hz]	Time [10ms]	Jump No.	m code
0	Positioning at 1-step speed	10000	50000000			-1
1	Positioning at 1-step speed	20000	50000000			-1
2	Positioning at 1-step speed	30000	50000000			-1
3	Positioning at 1-step speed	40000	50000000			-1
4	Positioning at 1-step speed	400000	50000000			-1
5	Positioning at 1-step speed	500000	50000000			-1
6	Dwell			100		-1
7	Positioning at 1-step speed	50000	50000000			-1

This window displays [X-axis table information edit window].

Item	Description
Title bar	Displays X/Y/XY-axis status information <ul style="list-style-type: none"> • Operation • Standby • Stopped
—	Highlights table No. line in execution

1	Introduction
2	Install Uninstall Start&Exit
3	Window and Operation Config
4	Creating Files
5	Data set
6	Setting The Connection
7	Data flow And Procedure
8	Debug In the Positioning
9	Print
10	Edit Function In data

8.2 Testing the Operation

STARTUP AND MAINTENANCE PRECAUTIONS



- Do not touch any terminal while the PLC's power is on.
Doing so may cause electrical shock or malfunctions.
- Before cleaning or retightening terminals, externally cut off all phases of the power supply.
Failure to do so may expose you to shock hazard.
- Before modifying the program under operation or performing operation for forcible output, running or stopping, carefully read the manual, and sufficiently ensure the safety.
An operation error may damage the machine or cause accidents.
- To test Zero-return, JOG operation and Positioning data, thoroughly read this manual, ensure the safe system operation
An operation error may damage the machine or cause accidents.
The response, such as the JOG operation, may be slow according to the running state of the personal computer at the time of the test operation. In the test operation, the PLC performance can be slower due to the busy state of personal computer.
 - End all other applications running except FX Configurator-FP.
 - At destination specification (refer to chapter 6), set the transmission speed at 38.4kbps or higher.

Testing each operation in the position start, Feed present value change, velocity change, zero return, JOG and MPG, switching the 20SSC-H into the test mode while operation monitoring.

8.2.1 Switching into test mode

Switching into FX Configurator-FP into test mode.

1 Follow any of the procedures below.

- Click  [Test On/Off].
- Select [Online] → [Test] → [Test On/Off].

FX Configurator-FP switches into test mode.

When switching test mode into monitor mode

- 1) Follow any of the procedures below when switching the test mode into monitor mode.
 - Click  [Test On/Off].
 - Select [Online] → [Test] → [Test On/Off].
- 2) FX Configurator-FP starts monitoring

8.2.2 Operation test in the positioning (except JOG/MPG)

Testing the operation in the 20SSC-H positioning (except into JOG/MPG) by test mode.

→ For the procedure to switch into test mode, refer to Subsection 8.2.1.

1 Follow any of the procedures below when switching the test mode into monitor mode.

- Click [Operation test X-axis] / [Operation test Y-axis].
- Select [Online] → [Test] → [Operation test] → [Operation test X-axis] / [Operation test Y-axis].

The position start tab in [Operation test X-axis] / [Operation test Y-axis] dialog box appears.

→ For Feed present value CHG tab, refer to Subsection 8.2.3.

→ For velocity change tab, refer to Subsection 8.2.4.

→ For zero return tab, refer to Subsection 8.2.5.

→ For JOG/MPG tab, refer to Subsection 8.2.6.

2 Set the items below.

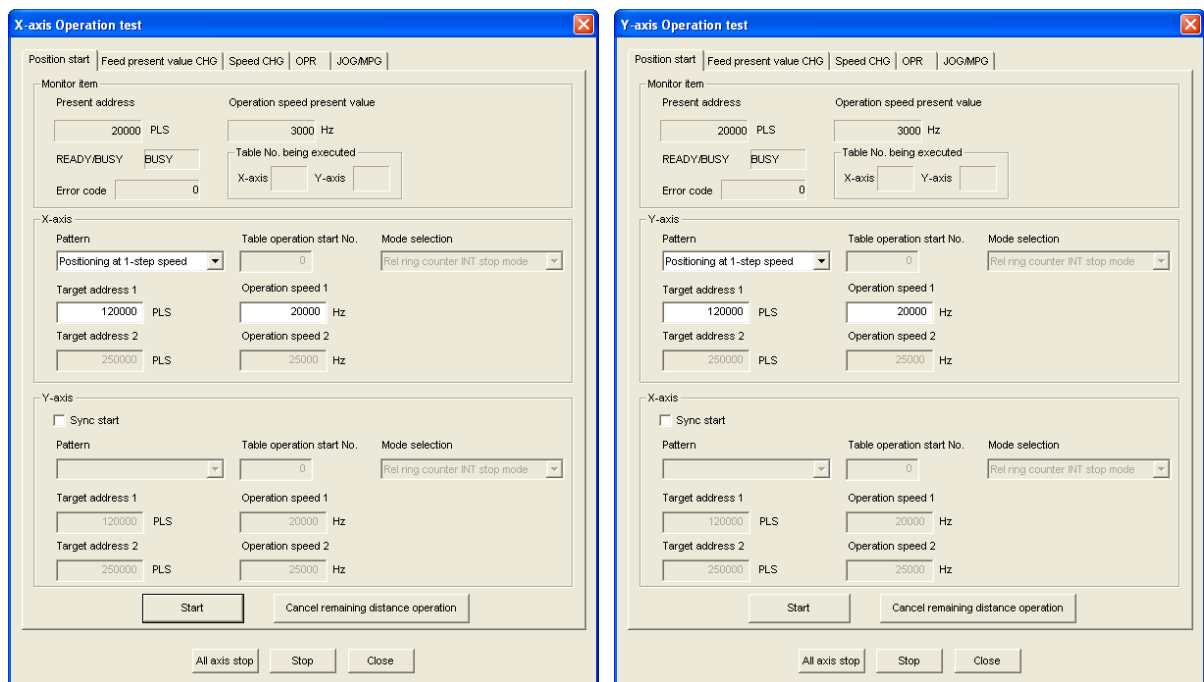

Item	Description
Monitor item	Displays present address, Operation speed present value, status information and Error code
Present address	Displays the present address [Unit : User unit*1]
Operation speed present value	Displays the operation speed present value [Unit : User unit*1]
READY/BUSY	Displays status information • READY : ON • BUSY : OFF
Table No. being executed	Displays X/Y-axis table No. in execution It is blank here at other than table operation
Error code	Displays error codes Displays 0 with no error

Item	Description
X/Y-axis	Sets the positioning operation along X/Y-axis
Sync start	Ticks off to start X and Y-axis simultaneously [Operation test X-axis] dialog box displays the check box in the Y-axis item [Operation test Y-axis] dialog box displays the check box in the X-axis item
Patterns	Sets/displays the operation pattern Available in [X-axis operation test] only <ul style="list-style-type: none"> Positioning at 1-step speed Interrupt stop at 1-step speed Positioning at 2-step speed Interrupt stop at 2-step speed Interrupt stop Variable speed operation MPG operation*2 Linear interpolation*2 Linear interpolation(interrupt)*2 X-axis table operation (available in [Operation test X-axis] dialog box) Y-axis table operation (available in [Operation test y-axis] dialog box) XY-axis table operation*2 Reciprocal movement instruction*3
Table operation start No.	Sets the table operation No. to start table operation Setting range : 0 to 299
Mode selection	Select the mode of interruption Interrupt stop at 1-step speed <ul style="list-style-type: none"> Rel ring counter INT stop mode Abs ring counter INT stop mode
Target address1*4	Sets the Target address1 Setting range : -2,147,483,648 to 2,147,483,647 [User unit]*1 Set the value within -2,147,483,648 to 2,147,483,647PLS in the converted pulse data*1
Operation speed1*4	Sets the Operation speed1 Set the speed at or below the maximum rotation speed*5 of servo motor Setting range : 1 to Maximum speed[User unit]*1 Set the value within 1 to 50,000,000Hz in the converted pulse data*1
Target address2*4	Sets the Target address2 Setting range : -2,147,483,648 to 2,147,483,647 [User unit]*1 Set the value within -2,147,483,648 to 2,147,483,647PLS in the converted pulse data*1
Operation speed2*4	Sets the Operation speed2 Set the speed at or below the maximum rotation speed*5 of servo motor Setting range : 1 to Maximum speed[User unit]*1 Set the value within 1 to 50,000,000Hz in the converted pulse data*1
<Start>	Starts the positioning operation with the pre-set contents
<Cancel remaining distance operation>	Cancels the standby in remaining distance operation, and ends the positioning operation
<All axis stop>	Stops all axis
<Stop>	Stops the axis in operation test
<Close>	Cancels the setting, and closes the dialog box

*1. For the user unit, refer to the following.

→ Refer to Section 5.1.

*2. Not available when ticking off [Simultaneous start].

*3. Reciprocal movement instruction is supported in the 20SSC-H Ver.1.10 or later.

*4. Not available depending on the operation pattern

*5. For the servo motor rotation speed and the operation speed (converted pulse data), refer to the following.

→ Refer to Section 5.1.3.

3 Click <Start>

20SSC-H starts the table operation with the pre-set contents.

1
Introduction

2
Install
Uninstall
Start&Exit

3
Window and
Operation
Config

4
Creating
Files

5
Data set

6
Setting
The
Connection

7
Data flow
And
Procedure

8
Debug
In the
Positioning

9
Print



10
Edit
Function
In data

8.2.3 Changing the present value

Changing the present value the 20SSC-H's present value by test mode.

→ For the procedure to switch into test mode, refer to Subsection 8.2.1.

1 Follow any of the procedures below.

- Click  [Operation test X-axis] /  [Operation test Y-axis].
- Select [Online] → [Test] → [Operation test] → [Operation test X-axis] / [Operation test Y-axis].

The position start tab in [Operation test X-axis] / [Operation test Y-axis] dialog box appears.

→ For position start tab, refer to Subsection 8.2.2.

→ For velocity change tab, refer to Subsection 8.2.4.

→ For zero return tab, refer to Subsection 8.2.5.

→ For JOG/MPG tab, refer to Subsection 8.2.6.

2 Click [Feed present value CHG] tab.

The display switches into [Feed present value CHG] tab.

3 Set each item for [Feed present value CHG].

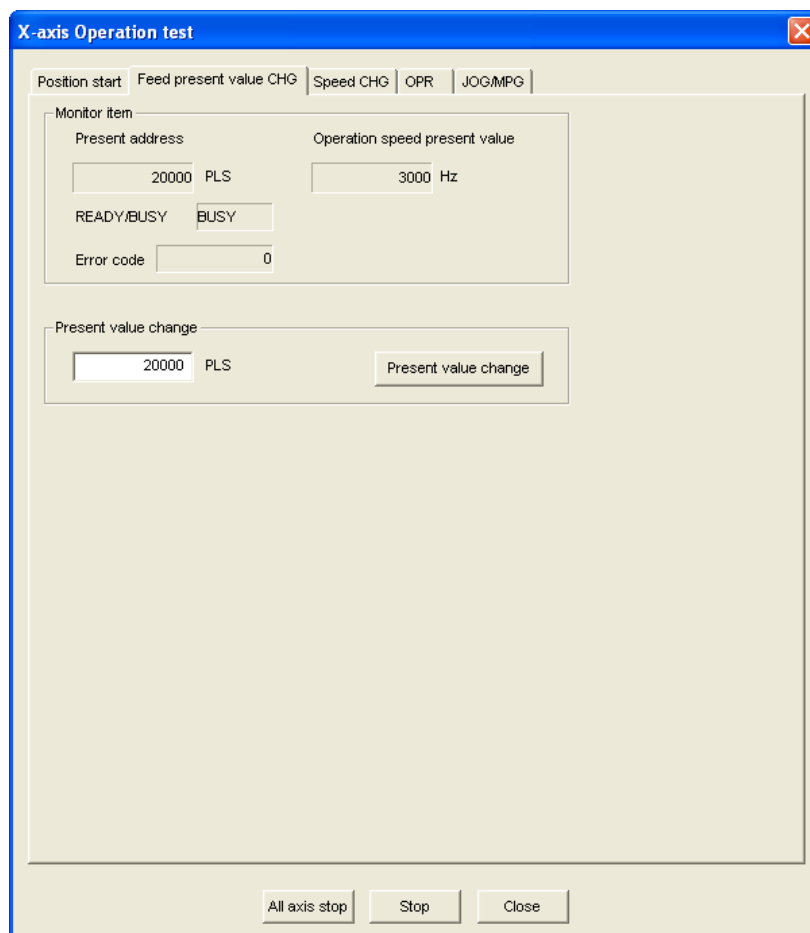

This window displays [X-axis Operation status] dialog box.

Item	Description
Monitor item	Displays present address, Operation speed present value, status information and Error code
Present address	Displays the present address [Unit : User unit* ¹]
Operation speed present value	Displays the operation speed present value [Unit : User unit* ¹]
READY/BUSY	Displays status information • READY : ON • BUSY : OFF
Error code	Displays error codes Displays 0 with no error
Present value change	Changes the present address to the specified one
Address	Sets the present address to be changed Setting range : -2,147,483,648 to 2,147,483,647 [User unit]* ¹
<Present value change>	Executes the present value change
<All axis stop>	Stops all axis
<Stop>	Stops the axis in operation test
<Close>	Cancels the setting, and closes the dialog box

*1. For the user unit, refer to the following.

→ Refer to Section 5.1.

4 Click <Present value change>.

FX Configurator-FP changes the present address to the specified value.

1

Introduction

2

Install
Uninstall
Start&Exit

3

Window and
Operation
Config

4

Creating
Files

5

Data set

6

Setting
The
Connection

7

Data flow
And
Procedure

8

Debug
In the
Positioning

9

Print

10

Edit
Function
In data

8.2.4 Speed change



Changing the operation speed and speed override setting in the following operations, by test mode.

→ For the procedure to switch into test mode, refer to Subsection 8.2.1.

→ For more details on each operation and the speed override function, refer to the FX3U-20SSC-H user's manual.

Function	Applicable operation pattern
Operation speed change	Mechanical zero return (High speed), JOG operation, Positioning at 1-step speed, Interrupt stop at 1-step speed, Positioning at 2-step speed, Interrupt stop at 2-step speed, Interrupt stop, Multi-speed operation, Linear interpolation, Linear interpolation (interrupt), Circular interpolation, Reciprocal movement instruction
Speed override	Mechanical zero return (High speed), JOG operation, Positioning at 1-step speed, Interrupt stop at 1-step speed, Positioning at 2-step speed, Interrupt stop at 2-step speed, Interrupt stop, Variable speed operation, Multi-speed operation, Linear interpolation, Linear interpolation (interrupt), Circular interpolation, Reciprocal movement instruction

1 Follow any of the procedures below.

- Click  [Operation test X-axis] /  [Operation test Y-axis].
- Select [Online] → [Test] → [Operation test] → [Operation test X-axis] / [Operation test Y-axis].

The position start tab in [Operation test X-axis] / [Operation test Y-axis] dialog box appears.

→ For position start tab, refer to Subsection 8.2.2.

→ For Feed present value CHG tab, refer to Subsection 8.2.3.

→ For zero return tab, refer to Subsection 8.2.5.

→ For JOG/MPG tab, refer to Subsection 8.2.6.

2 Click [Speed CHG] tab.

The display switches into [Speed CHG] tab.

3 Set each item for [Speed CHG].

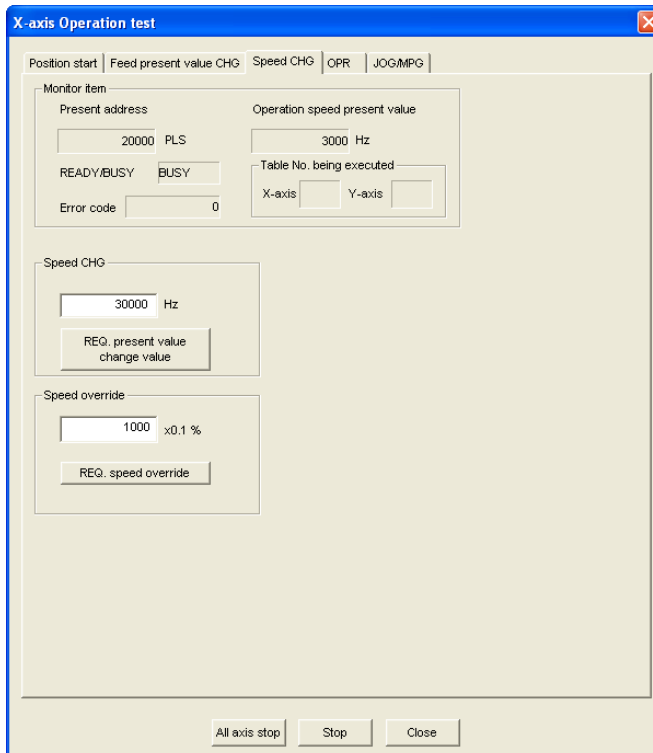

This window displays [X-axis Operation status] dialog box.

Item	Description
Monitor item	Displays present address, Operation speed present value, status information and Error code
Present address	Displays the present address [Unit : User unit* ¹]
Operation speed present value	Displays the operation speed present value [Unit : User unit* ¹]
READY/BUSY	Displays status information • READY : ON • BUSY : OFF
Table No. being executed	Display X/Y-axis table No. in execution This item is blank when using an operation pattern other than table operation
Error code	Displays error codes Displays 0 with no error
Speed CHG	Changes the speed to the specified one
Speed change	Sets the Operation speed When setting the speed at or above the maximum speed, the speed is set to the maximum speed. Set the speed at or below the maximum rotation speed* ² of servo motor Setting range : 1 to Maximum speed[User unit]* ¹ Set the value within 1 to 50,000,000Hz in the converted pulse data
<REQ. present value change value>	Executes the speed change
Speed override	Changes the operation speed override setting
Speed override	Sets the speed override ratio Setting range : 1 to 30000 [×0.1%]
<REQ. speed override>	Executes the speed override change
<All axis stop>	Stops all axis
<Stop>	Stops the axis in operation test
<Close>	Cancels the setting, and closes the dialog box

*1. For the user unit, refer to the following.

→ Refer to Section 5.1.

*2. For the servo motor rotation speed and the operation speed (converted pulse data), refer to the following.

→ Refer to Section 5.1.3.

4 Click <REQ. present value change value> / <REQ. speed override>.

1. <REQ. present value change value>

FX Configurator-FP changes the operation speed to the specified value.

2. <REQ. speed override>

FX Configurator-FP changes the operation speed at the specified ratio.



1	Introduction
2	Install Uninstall Start&Exit
3	Window and Operation Config
4	Creating Files
5	Data set
6	Setting The Connection
7	Data flow And Procedure
8	Debug In the Positioning
9	Print
10	Edit Function In data

8.2.5 Zero return

Executing the mechanical zero return by the OPR mode specified in test mode.

→ For the procedure to switch into test mode, refer to Subsection 8.2.1.

1 Follow any of the procedures below.

- Click  [Operation test X-axis] /  [Operation test Y-axis].
- Select [Online] → [Test] → [Operation test] → [Operation test X-axis] / [Operation test Y-axis].

The position start tab in [Operation test X-axis] / [Operation test Y-axis] dialog box appears.

→ For position start tab, refer to Subsection 8.2.2.

→ For Feed present value CHG tab, refer to Subsection 8.2.3.

→ For velocity change tab, refer to Subsection 8.2.4.

→ For JOG/MPG tab, refer to Subsection 8.2.6.

2 Click [OPR] tab.

The display switches into [OPR] tab.

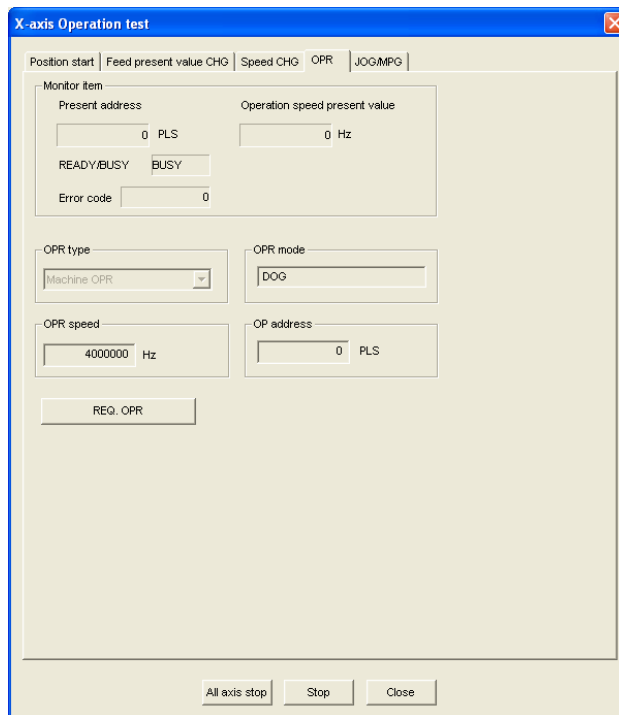

This window displays [X-axis Operation status] dialog box.

Item	Description
Monitor item	Displays present address, Operation speed present value, status information and Error code
Present address	Displays the present address [Unit : User unit* ¹]
Operation speed present value	Displays the operation speed present value [Unit : User unit* ¹]
READY/BUSY	Displays status information • READY : ON • BUSY : OFF
Error code	Displays error codes Displays 0 with no error
OPR type	Displays the machine OPR as an OPR type
OPR mode	Displays the OPR mode (Displays the OPR mode in the 20SSC-H positioning parameter) • DOG • Data set • Stopper #1 • Stopper #2
OPR speed	Displays the OPR speed(High speed) stored in the positioning parameter [Unit : User unit* ¹]
OP address	Displays the OP address stored in the positioning parameter [Unit : User unit* ¹]
<REQ. OPR>	Executes the mechanical OPR by the specified OPR type
<All axis stop>	Stops all axis
<Stop>	Stops the axis in operation test
<Close>	Cancels the setting, and closes the dialog box

*1. For the user unit, refer to the following.

→ Refer to Section 5.1.

3 Click <REQ. OPR>.

20SSC-H starts the OPR.

1	Introduction
2	Install Uninstall Start&Exit
3	Window and Operation Config
4	Creating Files
5	Data set
6	Setting The Connection
7	Data flow And Procedure
8	Debug In the Positioning
9	Print
10	Edit Function In data



8.2.6 JOG/MPG

Executing the JOG/MPG in test mode, also confirming the following operations, by JOG/MPG in the positioning control debug.

→ For the procedure to switch into test mode, refer to Subsection 8.2.1.

- Forward/Reverse rotation direction
- ON/OFF of the external input signals, i.e. Upper/Lower limit switch, zero signal and near-point DOG. signal
- Operation speed test(JOG only)
- Correction of Forward/Reverse rotation Backlash
- Travel distance

1 Follow any of the procedures below.

- Click  [Operation test X-axis] /  [Operation test Y-axis].
- Select [Online] → [Test] → [Operation test] → [Operation test X-axis] / [Operation test Y-axis].

The position start tab in [Operation test X-axis] / [Operation test Y-axis] dialog box appears.

→ For position start tab, refer to Subsection 8.2.2.

→ For Feed present value CHG tab, refer to Subsection 8.2.3.

→ For velocity change tab, refer to Subsection 8.2.4.

→ For zero return tab, refer to Subsection 8.2.5.

2 Click [JOG/MPG] tab.

The display switches into [JOG/MPG] tab.

3 Set each item for JOG/MPG.

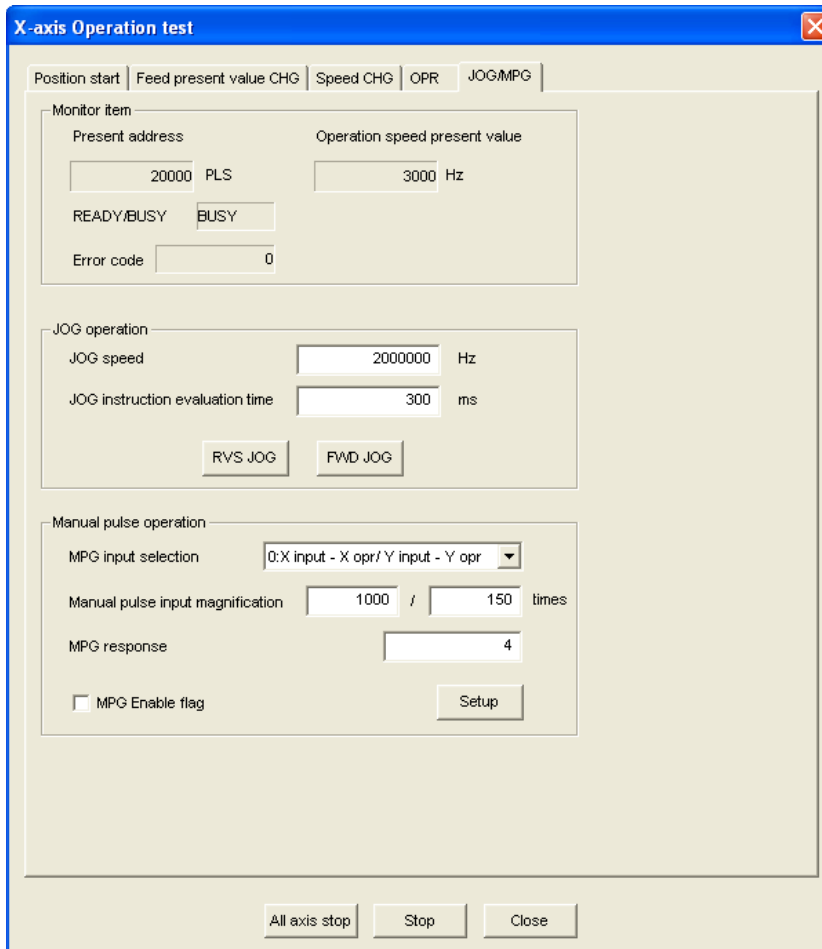

This window displays [X-axis Operation status] dialog box.

Item	Description
Monitor item	Displays present address, Operation speed present value, status information and Error code
Present address	Displays the present address [Unit : User unit* ¹]
Operation speed present value	Displays the operation speed present value [Unit : User unit* ¹]
READY/BUSY	Displays status information • READY : ON • BUSY : OFF
Error code	Displays error codes Displays 0 with no error
JOG operation	Executes the JOG at the specified JOG speed and JOG instruction evaluation time
JOG speed	Sets the JOG speed in 20SSC-H positioning parameter Setting range : 1 to Maximum speed [User unit* ¹] Set the value within 1 to 50,000,000Hz in the converted pulse data.
JOG instruction evaluation time	Sets the JOG instruction evaluation time in 20SSC-H positioning parameter Setting range : 0 to 5000ms
<RVS JOG>	Executes reverse JOG while held
<FWD JOG>	Executes forward JOG while held
Manual pulse operation	Sets the MPG operation
MPG input selection* ²	Sets the MPG input selection 0: X input - X opr / Y input - Y opr 1: X input / Y opr 2: X input - X and Y opr
Manual pulse input magnification	Sets the manual pulse input magnification (numerator/denominator) Setting range : (Numerator) 1 to 1,000,000 (Denominator) 1 to 1,000,000
MPG response	Sets the MPG response Setting range : 1 to 32767
MPG Enable flag	Enables the MPG operation when ticked off
<Setup>	Sets the MPG Enable flag and manual pulse input magnification (numerator/denominator)
<All axis stop>	Stops all axis
<Stop>	Stops the axis in operation test
<Close>	Cancels the setting, and closes the dialog box

*1. For the user unit, refer to the following.

*2. Available at X-axis operation test only.

→ Refer to Section 5.1.

4 Click <RVS JOG>, <FWD JOG> or <Setup>.

1. <RVS JOG>

20SSC-H executes the reverse JOG operation at the specified JOG speed and JOG instruction evaluation time.

2. <FWD JOG>

20SSC-H executes the forward JOG operation at the specified JOG speed and JOG instruction evaluation time.

3. <Setup>



FX Configurator-FP sets the MPG Enable flag and manual pulse input magnification (numerator/denominator).

8.2.7 Turning OFF m codes

Turning off the m code while monitor/test mode.

→ For the procedure to switch into test mode, refer to Subsection 8.2.1.

1 Follow any of the procedures below.

- Click  [m code off X-axis] /  [m code off Y-axis].
- Select [Online] → [Test] → [m code off] → [m code off X-axis] / [m code off Y-axis].

The m code at the selected axis turns OFF.

8.2.8 Stopping all axis

Stopping all axis while test mode.

→ For the procedure to switch into test mode, refer to Subsection 8.2.1.

1 Follow any of the procedures below.

- Click  [All axis stop command].
- Select [Online] → [Test] → [All axis stop].



All axis stops.

8.2.9 Error rest

Resetting the errors in monitor/test mode.

→ For the procedure to switch into test mode, refer to Subsection 8.2.1.

1 Follow any of the procedures below.

- Click  [Error reset X-axis] /  [Error reset Y-axis].
- Select [Online] → [Test] → [Error reset] → [Error reset X-axis] / [Error reset Y-axis].

The errors are reset at the selected axis.

8.2.10 Servo ON/OFF

Executing servo ON/OFF while test mode.

By servo ON/OFF, the servo motor turns into the state in the following table.

→ For the procedure to switch into test mode, refer to Subsection 8.2.1.

The servo motor state	
Servo ON	Locks servo motors and turns them into the standby state
Servo OFF	Unlocks servo motors, and also turns OFF the servo motor electromagnetic brake

The execution conditions for servo ON/OFF

Servo ON/OFF is executable when the execution conditions in the following table are fulfilled.

Menu	Operation	Execution conditions
All axis Servo ON/OFF	Servo ON all axis	• All axis (X and Y-axis) are executable for servo ON
	Servo OFF all axis	• X or Y-axis are executable for servo OFF
X-axis servo ON/OFF command	Servo ON X-axis	• X-axis status information in 20SSC-H is READY • X-axis servo status is READY ON and servo OFF
	Servo OFF X-axis	• X-axis status information in 20SSC-H is READY • X-axis servo status is servo ON
Y-axis servo ON/OFF command	Servo ON Y-axis	• Y-axis status information in 20SSC-H is READY • Y-axis servo status is READY ON and servo OFF
	Servo OFF Y-axis	• Y-axis status information in 20SSC-H is READY • Y-axis servo status is servo ON

1 Follow any of the procedures below depending on the content to be executed.

- When executing all axis servo ON/OFF
Select [Online] → [Test] → [All axis Servo On/Off].
- When executing servo ON/OFF along the specified axis
Select [Online] → [Test] → [Tool] → [X-axis Servo On/Off command] / [Y-axis Servo On/Off command]

Note

✓ mark appears on the left of the menu items while the servo is ON.

9. Print

9.1 Setting the printer

Setting the printer, paper and orientation.

1 Select → [File] → [Printer setup].

[Print Setup] dialog box appears.

2 Set each item for the print setup.

→ For print setup details, refer to the OS manual to be used.

→ For the printer property, refer to the printer manual to be used.

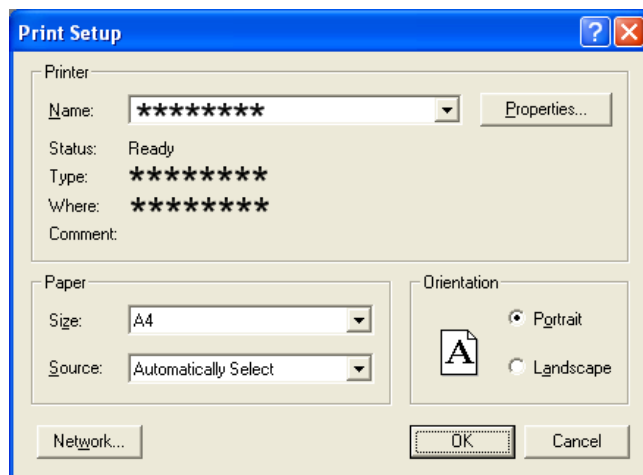

9.2 Printing

9.2.1 Setting the item to print

Printing the positioning parameters, servo parameters and table information.

1 Follow any of the procedures below.

- Click  [Print].
- Select [File] → [Print].

The [Print] dialog box appears.

2 Set the item to print.

[Print] dialog box has [Item specification], [Servo parameters] and [table information] tabs. Click the tab to set.

For [Servo parameters] and [table information] tabs, refer to the following pages.

1. [Item specification] tab

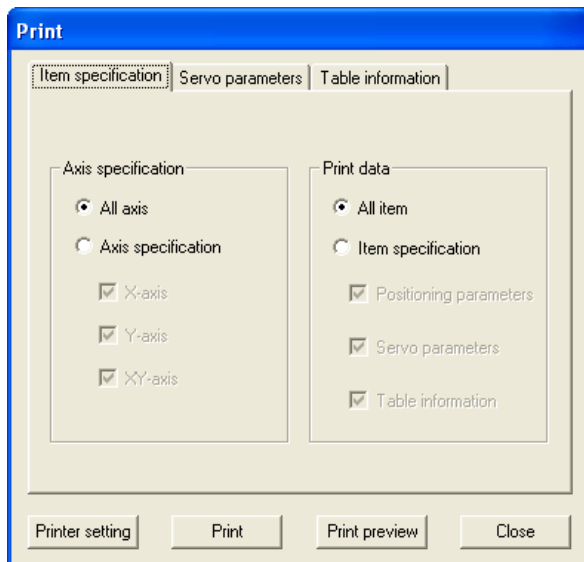

Item	Description
Axis specification	Specifies the axis data to print
All axis	Prints X, Y and XY-axis data
Axis specification	Prints the ticked axis data <ul style="list-style-type: none"> • X-axis • Y-axis • XY-axis
Print data	Specifies the data type to print
All item	Prints [Positioning parameters], [Servo parameters] and [Table information]
Item specification	Prints the ticked data item <ul style="list-style-type: none"> • Positioning parameters • Servo parameters • Table information
<Printer setting>	Displays [Printer setting] dialog box → Refer to Section 9.1.
<Print>	Outputs to printer depending on the specified contents
<Print preview>	Displays the print preview
<Close>	Closes the dialog box without printing

1	Introduction
2	Install/Uninstall/Start&Exit
3	Window and Operation Config
4	Creating Files
5	Data set
6	Setting The Connection
7	Data flow And Procedure
8	Debug In the Positioning
9	Print
10	Edit Function In data

2. [Servo parameters] tab

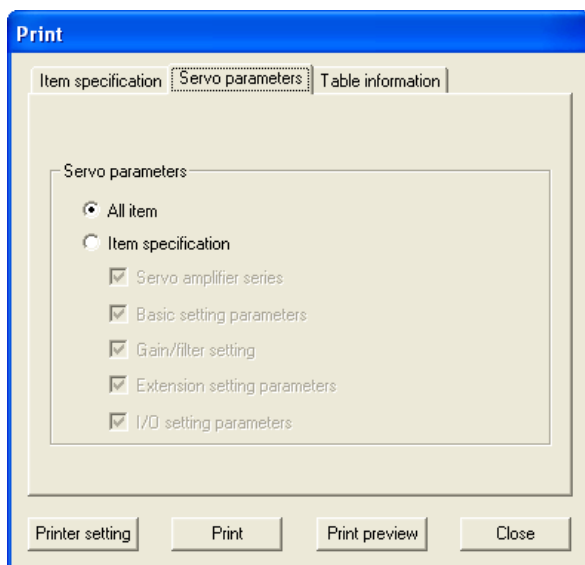

Item	Description
Servo parameters	Specifies the axis data to print
All item	Prints X, Y and XY-axis data
Item specification	Prints the ticked items <ul style="list-style-type: none"> • Servo amplifier series • Basic setting parameters • Gain/filter setting • Extension setting parameters • I/O setting parameters
<Printer setting>	Displays [Printer setting] dialog box → Refer to Section 9.1.
<Print>	Outputs to printer depending on the specified contents
<Print preview>	Displays the print preview
<Close>	Closes the dialog box without printing

3. [Table information] tab

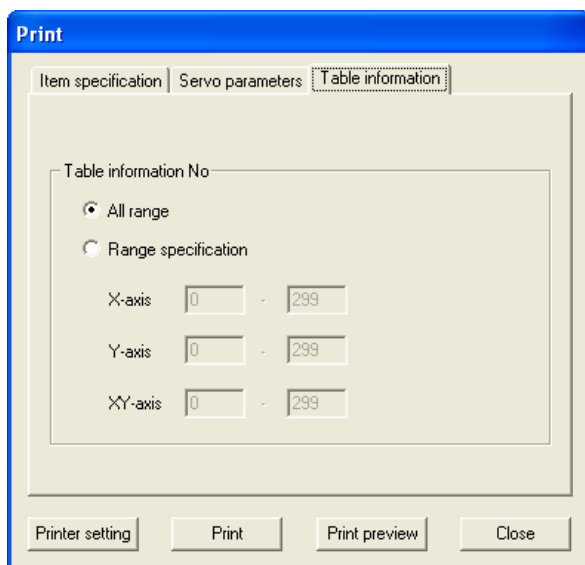

Item	Description
Table information No.	Specifies the axis data to print
All range	Prints all range of the table information
Range specification	Sets the table information printing range for each axis Each axis setting range : 0 to 299 <ul style="list-style-type: none"> • X-axis • Y-axis • XY-axis
<Printer setting>	Displays [Printer setting] dialog box → Refer to Section 9.1.
<Print>	Outputs to printer depending on the specified contents
<Print preview>	Displays the print preview
<Close>	Closes the dialog box without printing

1 Introduction

2 Install
Uninstall
Start&Exit

3 Window and
Operation
Config

4 Creating
Files

5 Data set

6 Setting
The
Connection

7 Data flow
And
Procedure

8 Debug
In the
Positioning

9 Print

10 Edit
Function
In data

9.2.2 Printing examples

1. Positioning parameters printing examples

Parameter name		Data set range	Data
System of units		0: Motor (PLS, Hz) 1: Mechanical (um, cm/min) 2: Mechanical (0.0001inch, inch/min) 3: Mechanical (mdeg, 10deg/min) 4: Combined (um, Hz) 5: Combined (0.0001inch, Hz) 6: Combined (mdeg, Hz)	0
Pulse rate	Pulse per rotation	---	---
Feed rate	Travel per rotation	---	---
Position data magnification		0: X 1 times 1: X 10 times 2: X 100 times 3: X 1000 times	0
Ring counter setting		0: Invalid 1: Valid	0
Ring counter upper limit value		---	---

2. Servo parameters printing examples

Parameter name	Data set range	Data
Output signal 1 function selection	0,1,2,3,4,5,6,7,8,9,A,C,F,11	5: MBR
Output signal 2 function selection	0,1,2,3,4,5,6,7,8,9,A,C,F,11	4: INP
Output signal 3 function selection	0,1,2,3,4,5,6,7,8,9,A,C,F,11	3: ALM

3. Table information printing examples

No.	Command code	Address	Speed	Time	Jump No.	m code
0	Positioning at 1-step speed		10000	80000	---	---
1	Positioning at 1-step speed		15000	80000	---	---
2	Positioning at 1-step speed		30000	4000000	---	---
3	Positioning at 1-step speed		4000	20000	---	---
4	Dwell		---	---	100	---
5	Positioning at 1-step speed		0	400000	---	---
6	End		---	---	---	---
7	Positioning at 1-step speed		10000	1	---	---
8	Positioning at 1-step speed		15000	1	---	---
9	Positioning at 1-step speed		30000	1	---	---
10	Positioning at 1-step speed		4000	1	---	---
11	Dwell		---	---	100	---
12	Positioning at 1-step speed		10000	80000	---	---
13	Positioning at 1-step speed		15000	80000	---	---
14	Positioning at 1-step speed		3000	4000000	---	---
15	Positioning at 1-step speed		4000	20000	---	---
16						
17						

10. Edit function in data setting

10.1 Cut / Copy / Paste / Select all

Partially cutting/copying/pasting the positioning parameter settings. Also Cutting/copying the value in a table of Microsoft® Excel or Word, and pasting the data cut/copied onto the FX Configurator-FP positioning parameters.

10.1.1 Cut/Copy

1 Select cells to cut/copy.

No.	Command code	Address [PLS]	Speed [Hz]	Time [10ms]	Jump No.	m code
0	Positioning at 1-step speed	10000	4000			-1
1	Positioning at 1-step speed	20000	50000			-1
2	Positioning at 1-step speed	300000	100000			-1
3	Positioning at 1-step speed	500000	500000			-1
4	Dwell			100		-1
5	Positioning at 1-step speed	0	500000			-1
6	End					
7						
8						

2 Follow any of the procedures below.

- Click [Cut] / [Copy].
- Right-click to select [Cut] / [Copy].
- Select [Edit] → [Cut] / [Copy].

No.	Command code	Address [PLS]	Speed [Hz]	Time [10ms]	Jump No.	m code
0	Positioning at 1-step speed	0	4000			-1
1	Positioning at 1-step speed	0	50000			-1
2	Positioning at 1-step speed	0	100000			-1
3	Positioning at 1-step speed	500000	500000			-1
4	Dwell			100		-1
5	Positioning at 1-step speed	0	500000			-1
6	End					
7						
8						

Caution on cutting

The selected range is treated as default value.

1	Introduction
2	Install Uninstall Start&Exit
3	Window and Operation Config
4	Creating Files
5	Data set
6	Setting The Connection
7	Data flow And Procedure
8	Debug In the Positioning
9	Print
10	Edit Function In data

10.1.2 Paste

1 Select cells to paste.

No.	Command code	Address [PLS]	Speed [Hz]	Time [10ms]	Jump No.	m code
0	Positioning at 1-step speed	0	4000			-1
1	Positioning at 1-step speed	0	50000			-1
2	Positioning at 1-step speed	0	100000			-1
3	Positioning at 1-step speed	500000	500000			-1
4	Dwell			100		-1
5	Positioning at 1-step speed	0	500000			-1
6	Positioning at 1-step speed	0	1			-1
7	Positioning at 1-step speed	0	1			-1
8	Positioning at 1-step speed	0	1			-1
9	Positioning at 1-step speed	0	1			-1
10						
11						

2 Follow any of the procedures below.

- Click  [Paste].
- Right-click to select [Paste].
- Select [Edit] → [Paste].

No.	Command code	Address [PLS]	Speed [Hz]	Time [10ms]	Jump No.	m code
0	Positioning at 1-step speed	0	4000			-1
1	Positioning at 1-step speed	0	50000			-1
2	Positioning at 1-step speed	0	100000			-1
3	Positioning at 1-step speed	500000	500000			-1
4	Dwell			100		-1
5	Positioning at 1-step speed	10000	500000			-1
6	Positioning at 1-step speed	20000	1			-1
7	Positioning at 1-step speed	300000	1			-1
8	Positioning at 1-step speed	0	1			-1
9	Positioning at 1-step speed	0	1			-1
10						
11						

10.1.3 Select all

Cutting/copying all range of table information, and pasting.
The data items inconsistency between axis disables all-range-paste.

1 Select [Edit] → [Select all].

No.	Command code	Address [PLS]	Speed [Hz]	Time [10ms]	Jump No.	m code
0	Positioning at 1-step speed	10000	4000			-1
1	Positioning at 1-step speed	20000	50000			-1
2	Positioning at 1-step speed	300000	100000			-1
3	Positioning at 1-step speed	500000	500000			-1
4	Dwell			100		-1
5	Positioning at 1-step speed	10000	4000			-1
6	Positioning at 1-step speed	20000	50000			-1
7	Positioning at 1-step speed	300000	100000			-1
8	Dwell			100		-1
9	End					
10						
11						

2 Paste the all range data.

→ For the procedure to paste, refer to Section 10.1.2.

10.2 Cursor jump

The cursor jumps to the table information No. specified by the table information edit window.

1 Select [Edit] → [Jump].

[JUMP] dialog box appears.

2 Set the destination table information No. in the table information edit window.

Item	Description
Jump No.	Sets the destination table information No. in the table information edit window Setting range : 0 to 299

The Displayed message

When the value input is out of range, the following message appears.



3 Click <OK>.

The cursor jumps to the table information No. specified by JUMP No.

1	Introduction
2	Install Uninstall Start&Exit
3	Window and Operation Config
4	Creating Files
5	Data set
6	Setting The Connection
7	Data flow And Procedure
8	Debug In the Positioning
9	Print
10	Edit Function In data

10.3 Initializing rows/columns

Initializing the rows/columns selected in the table information edit window.
Multiple rows/columns are selectable to initialize.

1 Select the part of rows/columns to initialize.

2 Follow any of the procedures below.

- Right-click to select [Clear row] / [Clear column].
- Select [Edit] → [Clear row] / [Clear column].

10.4 Insert row

Insert rows by the number of rows selected on the table information edit window.

1 Select cells to Insert row

No.	Command code	Address [PLS]	Speed [Hz]	Time [10ms]	Jump No.	m code
0	Positioning at 1-step speed	0	4000			-1
1	Positioning at 1-step speed	0	500000			-1
2	Positioning at 1-step speed	0	1000000			-1
3	Positioning at 1-step speed	500000	5000000			-1
4	Dwell			100		-1
5	Positioning at 1-step speed	0	1			-1
6	Positioning at 1-step speed	0	1			-1
7	Positioning at 1-step speed	0	1			-1
8	Positioning at 1-step speed	0	1			-1
9	Positioning at 1-step speed	0	1			-1
10						
11						
12						

2 Follow any of the procedures below.

- Right-click to select [Insert row].
- Select [Edit] → [Insert row].

No.	Command code	Address [PLS]	Speed [Hz]	Time [10ms]	Jump No.	m code
0	Positioning at 1-step speed	0	4000			-1
1	Positioning at 1-step speed	0	500000			-1
2	Positioning at 1-step speed	0	1000000			-1
3	Positioning at 1-step speed	500000	5000000			-1
4	Dwell			100		-1
5						
6	Positioning at 1-step speed	0	1			-1
7	Positioning at 1-step speed	0	1			-1
8	Positioning at 1-step speed	0	1			-1
9	Positioning at 1-step speed	0	1			-1
10	Positioning at 1-step speed	0	1			-1
11						
12						

10.5 Delete row

Delete rows by the number of rows selected on the table information edit window.

1 Select cells to Delete row.

No.	Command code	Address [PLS]	Speed [Hz]	Time [10ms]	Jump No.	m code
0	Positioning at 1-step speed	0	4000			-1
1	Positioning at 1-step speed	0	500000			-1
2	Positioning at 1-step speed	0	1000000			-1
3	Positioning at 1-step speed	500000	5000000			-1
4	Dwell			100		-1
5						
6	Positioning at 1-step speed	0	1			-1
7	Positioning at 1-step speed	0	1			-1
8	Positioning at 1-step speed	0	1			-1
9	Positioning at 1-step speed	0	1			-1
10	Positioning at 1-step speed	0	1			-1
11						
12						

2 Follow any of the procedures below.

- Right-click to select [Delete row].
- Select [Edit] → [Delete row].

No.	Command code	Address [PLS]	Speed [Hz]	Time [10ms]	Jump No.	m code
0	Positioning at 1-step speed	0	4000			-1
1	Positioning at 1-step speed	0	500000			-1
2	Positioning at 1-step speed	0	1000000			-1
3	Positioning at 1-step speed	500000	5000000			-1
4	Dwell			100		-1
5						
6	Positioning at 1-step speed	0	1			-1
7	Positioning at 1-step speed	0	1			-1
8	Positioning at 1-step speed	0	1			-1
9	Positioning at 1-step speed	0	1			-1
10						
11						
12						

10.6 Initializing data

Initializing the positioning parameters, servo parameters and table information along each axis.

1 Select [Tool] → [Initialize data].

[Initialize data] dialog box appears.

2 Set the data to initialize.

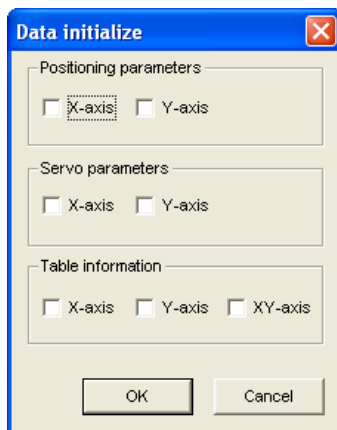

Item	Description
Positioning Parameters	Initializes the positioning parameters along the ticked axis <ul style="list-style-type: none"> • X-axis • Y-axis
Servo Parameters	Initializes the servo parameters along the ticked axis <ul style="list-style-type: none"> • X-axis • Y-axis
Table Information	Initializes the table information along the ticked axis <ul style="list-style-type: none"> • X-axis • Y-axis • XY-axis

Warranty

Please confirm the following product warranty details before using this product.

1. Gratis Warranty Term and Gratis Warranty Range

If any faults or defects (hereinafter "Failure") found to be the responsibility of Mitsubishi occurs during use of the product within the gratis warranty term, the product shall be repaired at no cost via the sales representative or Mitsubishi Service Company. However, if repairs are required onsite at domestic or overseas location, expenses to send an engineer will be solely at the customer's discretion. Mitsubishi shall not be held responsible for any re-commissioning, maintenance, or testing on-site that involves replacement of the failed module.

[Gratis Warranty Term]

The gratis warranty term of the product shall be for one year after the date of purchase or delivery to a designated place. Note that after manufacture and shipment from Mitsubishi, the maximum distribution period shall be six (6) months, and the longest gratis warranty term after manufacturing shall be eighteen (18) months. The gratis warranty term of repair parts shall not exceed the gratis warranty term before repairs.

[Gratis Warranty Range]

- 1) The range shall be limited to normal use within the usage state, usage methods and usage environment, etc., which follow the conditions and precautions, etc., given in the instruction manual, user's manual and caution labels on the product.
- 2) Even within the gratis warranty term, repairs shall be charged for in the following cases.
 - a) Failure occurring from inappropriate storage or handling, carelessness or negligence by the user. Failure caused by the user's hardware or software design.
 - b) Failure caused by unapproved modifications, etc., to the product by the user.
 - c) When the Mitsubishi product is assembled into a user's device, Failure that could have been avoided if functions or structures, judged as necessary in the legal safety measures the user's device is subject to or as necessary by industry standards, had been provided.
 - d) Failure that could have been avoided if consumable parts (battery, backlight, fuse, etc.) designated in the instruction manual had been correctly serviced or replaced.
 - e) Relay failure or output contact failure caused by usage beyond the specified Life of contact (cycles).
 - f) Failure caused by external irresistible forces such as fires or abnormal voltages, and failure caused by force majeure such as earthquakes, lightning, wind and water damage.
 - g) Failure caused by reasons unpredictable by scientific technology standards at time of shipment from Mitsubishi.
 - h) Any other failure found not to be the responsibility of Mitsubishi or that admitted not to be so by the user.

2. Onerous repair term after discontinuation of production

- 1) Mitsubishi shall accept onerous product repairs for seven (7) years after production of the product is discontinued. Discontinuation of production shall be notified with Mitsubishi Technical Bulletins, etc.
- 2) Product supply (including repair parts) is not available after production is discontinued.

3. Overseas service

Overseas, repairs shall be accepted by Mitsubishi's local overseas FA Center. Note that the repair conditions at each FA Center may differ.

4. Exclusion of loss in opportunity and secondary loss from warranty liability

Regardless of the gratis warranty term, Mitsubishi shall not be liable for compensation of damages caused by any cause found not to be the responsibility of Mitsubishi, loss in opportunity, lost profits incurred to the user or third person by Failures of Mitsubishi products, special damages and secondary damages whether foreseeable or not, compensation for accidents, and compensation for damages to products other than Mitsubishi products, replacement by the user, maintenance of on-site equipment, start-up test run and other tasks.

5. Changes in product specifications

The specifications given in the catalogs, manuals or technical documents are subject to change without prior notice.

6. Product application

- 1) In using the Mitsubishi MELSEC programmable logic controller, the usage conditions shall be that the application will not lead to a major accident even if any problem or fault should occur in the programmable logic controller device, and that backup and fail-safe functions are systematically provided outside of the device for any problem or fault.
- 2) The Mitsubishi programmable logic controller has been designed and manufactured for applications in general industries, etc. Thus, applications in which the public could be affected such as in nuclear power plants and other power plants operated by respective power companies, and applications in which a special quality assurance system is required, such as for Railway companies or Public service purposes shall be excluded from the programmable logic controller applications.

In addition, applications in which human life or property that could be greatly affected, such as in aircraft, medical applications, incineration and fuel devices, manned transportation, equipment for recreation and amusement, and safety devices, shall also be excluded from the programmable logic controller range of applications.

However, in certain cases, some applications may be possible, providing the user consults their local Mitsubishi representative outlining the special requirements of the project, and providing that all parties concerned agree to the special circumstances, solely at the users discretion.

Revised History

Date	Revision	Description
12/2005	A	First Edition
1/2007	B	Added items for Ver.1.10 Supports FX3U-20SSC-H (Ver.1.10) <ul style="list-style-type: none"> • Ring counter setting added • Servo parameter transfer mode selection added • Mode selection added to the Interrupt stop at 1-step speed • Reciprocal movement instruction added • Add the following function of MPG operation. <ul style="list-style-type: none"> - MPG input selection - MPG response • System Reset added • Servo parameter update stop added New features <ul style="list-style-type: none"> • Insert row / Delete row added Clerical error correction
7/2007	C	Added items for Ver.1.20 Supports FX3U-20SSC-H (Ver.1.20) <ul style="list-style-type: none"> • Sudden stop deceleration time added • Sudden stop interpolation time constant added • Sudden stop selection added • Interpolation gear ratio selection added • Positioning completion signal output waiting time added • Positioning parameter change completion flag added • Real current value monitor added <ul style="list-style-type: none"> - Real current address • Received target value monitor added <ul style="list-style-type: none"> - Received target address - Received target speed
1/2008	D	Added items for Ver.1.30 <ul style="list-style-type: none"> • Microsoft® Windows® Vista added to the applicable Operating Systems of the personal computer. • Connection via GOT1000 (GT15, GT11) series transparent mode added.

OPERATION MANUAL

FX Configurator-FP



HEAD OFFICE: TOKYO BUILDING, 2-7-3 MARUNOUCHI, CHIYODA-KU, TOKYO 100-8310, JAPAN
HIMEJI WORKS: 840, CHIYODA CHO, HIMEJI, JAPAN

MODEL	SW-FXSSC-O-E
MODEL CODE	09R916

HEADQUARTERS

MITSUBISHI ELECTRIC EUROPE B.V. **EUROPE**
 German Branch
 Gothaer Straße 8
D-40880 Ratingen
 Phone: +49 (0)2102 / 486-0
 Fax: +49 (0)2102 / 486-1120

MITSUBISHI ELECTRIC EUROPE B.V. **CZECH REPUBLIC**
 Czech Branch
 Avenir Business Park, Radlická 714/113a
CZ-158 00 Praha 5
 Phone: +420 (0)251 551 470
 Fax: +420 (0)251-551-471

MITSUBISHI ELECTRIC EUROPE B.V. **FRANCE**
 French Branch
 25, Boulevard des Bouvets
F-92741 Nanterre Cedex
 Phone: +33 (0)1 / 55 68 55 68
 Fax: +33 (0)1 / 55 68 57 57

MITSUBISHI ELECTRIC EUROPE B.V. **IRELAND**
 Irish Branch
 Westgate Business Park, Ballymount
IRL-Dublin 24
 Phone: +353 (0)1 4198800
 Fax: +353 (0)1 4198890

MITSUBISHI ELECTRIC EUROPE B.V. **ITALY**
 Italian Branch
 Viale Colleoni 7
I-20041 Agrate Brianza (MI)
 Phone: +39 039 / 60 53 1
 Fax: +39 039 / 60 53 312

MITSUBISHI ELECTRIC EUROPE B.V. **SPAIN**
 Spanish Branch
 Carretera de Rubí 76-80
E-08190 Sant Cugat del Vallés (Barcelona)
 Phone: 902 131121 // +34 935653131
 Fax: +34 935891579

MITSUBISHI ELECTRIC EUROPE B.V. **UK**
 UK Branch
 Travellers Lane
UK-Hatfield, Herts. AL10 8XB
 Phone: +44 (0)1707 / 27 61 00
 Fax: +44 (0)1707 / 27 86 95

MITSUBISHI ELECTRIC CORPORATION **JAPAN**
 Office Tower "Z" 14 F
 8-12,1 chome, Harumi Chuo-Ku
Tokyo 104-6212
 Phone: +81 3 622 160 60
 Fax: +81 3 622 160 75

MITSUBISHI ELECTRIC AUTOMATION, Inc. **USA**
 500 Corporate Woods Parkway
Vernon Hills, IL 60061
 Phone: +1 847 478 21 00
 Fax: +1 847 478 22 53

EUROPEAN REPRESENTATIVES

GEVA **AUSTRIA**
 Wiener Straße 89
AT-2500 Baden
 Phone: +43 (0)2252 / 85 55 20
 Fax: +43 (0)2252 / 488 60

TEHNIKON **BELARUS**
 Oktyabrskaya 16/5, Off. 703-711
BY-220030 Minsk
 Phone: +375 (0)17 / 210 46 26
 Fax: +375 (0)17 / 210 46 26

Koning & Hartman b.v. **BELGIUM**
 Woluwelaan 31
BE-1800 Vilvoorde
 Phone: +32 (0)2 / 257 02 40
 Fax: +32 (0)2 / 257 02 49

INEA BH d.o.o. **BOSNIA AND HERZEGOVINA**
 Aleja Lipa 56
BA-71000 Sarajevo
 Phone: +387 (0)33 / 921 164
 Fax: +387 (0)33 / 524 539

AKHNATON **BULGARIA**
 4 Andrej Ljapchev Blvd. Pb 21
BG-1756 Sofia
 Phone: +359 (0)2 / 817 6004
 Fax: +359 (0)2 / 97 44 06 1

INEA CR d.o.o. **CROATIA**
 Losinjska 4 a
HR-10000 Zagreb
 Phone: +385 (0)1 / 36 940 -01 / -02 / -03
 Fax: +385 (0)1 / 36 940 -03

AutoCont C.S. s.r.o. **CZECH REPUBLIC**
 Technologická 374/6
CZ-708 00 Ostrava-Pustkovec
 Phone: +420 595 691 150
 Fax: +420 595 691 199

B:TECH A.S. **CZECH REPUBLIC**
 U Borové 69
CZ-58001 Havlíčkův Brod
 Phone: +420 (0)569 777 777
 Fax: +420 (0)569-777 778

Beijer Electronics A/S **DENMARK**
 Lykkegårdsvvej 17, 1.
DK-4000 Roskilde
 Phone: +45 (0)46 / 75 76 66
 Fax: +45 (0)46 / 75 56 26

Beijer Electronics Eesti OÜ **ESTONIA**
 Pärnu mnt.160i
EE-11317 Tallinn
 Phone: +372 (0)6 / 51 81 40
 Fax: +372 (0)6 / 51 81 49

Beijer Electronics OY **FINLAND**
 Jaakonkatu 2
FIN-01620 Vantaa
 Phone: +358 (0)207 / 463 500
 Fax: +358 (0)207 / 463 501

UTEKO A.B.E.E. **GREECE**
 5, Mavrogenous Str.
GR-18542 Piraeus
 Phone: +30 211 / 1206 900
 Fax: +30 211 / 1206 999

MELTRADE Ltd. **HUNGARY**
 Fertő utca 14.
HU-1107 Budapest
 Phone: +36 (0)1 / 431-9726
 Fax: +36 (0)1 / 431-9727

Beijer Electronics SIA **LATVIA**
 Vestienas iela 2
LV-1035 Riga
 Phone: +371 (0)784 / 2280
 Fax: +371 (0)784 / 2281

Beijer Electronics UAB **LITHUANIA**
 Savanoriu Pr. 187
LT-02300 Vilnius
 Phone: +370 (0)5 / 232 3101
 Fax: +370 (0)5 / 232 2980

EUROPEAN REPRESENTATIVES

ALFATRADE Ltd. **MALTA**
 99, Paola Hill
Malta- Paola PLA 1702
 Phone: +356 (0)21 / 697 816
 Fax: +356 (0)21 / 697 817

INTEHSIS srl **MOLDOVA**
 bld. Traian 23/1
MD-2060 Kishinev
 Phone: +373 (0)22 / 66 4242
 Fax: +373 (0)22 / 66 4280

Koning & Hartman b.v. **NETHERLANDS**
 Haarlerbergweg 21-23
NL-1101 CH Amsterdam
 Phone: +31 (0)20 / 587 76 00
 Fax: +31 (0)20 / 587 76 05

Beijer Electronics AS **NORWAY**
 Postboks 487
NO-3002 Drammen
 Phone: +47 (0)32 / 24 30 00
 Fax: +47 (0)32 / 84 85 77

MPL Technology Sp. z o.o. **POLAND**
 Ul. Krakowska 50
PL-32-083 Balice
 Phone: +48 (0)12 / 630 47 00
 Fax: +48 (0)12 / 630 47 01

Sirius Trading & Services srl **ROMANIA**
 Aleea Lacul Morii Nr. 3
RO-060841 Bucuresti, Sector 6
 Phone: +40 (0)21 / 430 40 06
 Fax: +40 (0)21 / 430 40 02

Craft Con. & Engineering d.o.o. **SERBIA**
 Bulevar Svetog Cara Konstantina 80-86
SER-18106 Nis
 Phone: +381 (0)18 / 292-24-4/5
 Fax: +381 (0)18 / 292-24-4/5

INEA SR d.o.o. **SERBIA**
 Izletnicka 10
SER-113000 Smederevo
 Phone: +381 (0)26 / 617 163
 Fax: +381 (0)26 / 617 163

AutoCont Control s.r.o. **SLOVAKIA**
 Radlinského 47
SK-02601 Dolny Kubin
 Phone: +421 (0)43 / 5868210
 Fax: +421 (0)43 / 5868210

CS MTrade Slovensko, s.r.o. **SLOVAKIA**
 Vajanskeho 58
SK-92101 Piestany
 Phone: +421 (0)33 / 7742 760
 Fax: +421 (0)33 / 7735 144

INEA d.o.o. **SLOVENIA**
 Stegne 11
SI-1000 Ljubljana
 Phone: +386 (0)1 / 513 8100
 Fax: +386 (0)1 / 513 8170

Beijer Electronics AB **SWEDEN**
 Box 426
SE-20124 Malmö
 Phone: +46 (0)40 / 35 86 00
 Fax: +46 (0)40 / 35 86 02

Econotec AG **SWITZERLAND**
 Hinterdorfstr. 12
CH-8309 Nürensdorf
 Phone: +41 (0)44 / 838 48 11
 Fax: +41 (0)44 / 838 48 12

GTS **TURKEY**
 Dariülaceze Cad. No. 43 KAT. 2
TR-34384 Okmeydanı-Istanbul
 Phone: +90 (0)212 / 320 1640
 Fax: +90 (0)212 / 320 1649

CSC Automation Ltd. **UKRAINE**
 4-B, M. Raskovoyi St.
UA-02660 Kiev
 Phone: +380 (0)44 / 494 33 55
 Fax: +380 (0)44 / 494-33-66

EURASIAN REPRESENTATIVES

Kazpromautomatiks Ltd. **KAZAKHSTAN**
 Mustafina Str. 7/2
KAZ-470046 Karaganda
 Phone: +7 7212 / 50 11 50
 Fax: +7 7212 / 50 11 50

MIDDLE EAST REPRESENTATIVES

TEXEL ELECTRONICS Ltd. **ISRAEL**
 2 Ha'umanut, P.O.B. 6272
IL-42160 Netanya
 Phone: +972 (0)9 / 863 39 80
 Fax: +972 (0)9 / 885 24 30

CEG INTERNATIONAL **LEBANON**
 Cebaco Center/Block A Autostrade DORA
Lebanon - Beirut
 Phone: +961 (0)1 / 240 430
 Fax: +961 (0)1 / 240 438

AFRICAN REPRESENTATIVE

CBI Ltd. **SOUTH AFRICA**
 Private Bag 2016
ZA-1600 Isando
 Phone: +27 (0)11 / 928 2000
 Fax: +27 (0)11 / 392 2354