

ABE7H16R50

passive connection sub-base ABE7 - 16 inputs or outputs

Modicon ABE7 range

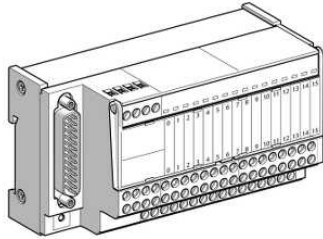

Main

Range of product	Advantys Telefast ABE7
Product or component type	Passive discrete I/O sub-base
Sub-base type	I/O sub-base
[Us] rated supply voltage	19...30 V conforming to IEC 61131-2
Number of channels	16
Number of terminal per channel	1
Connections - terminals	Screw type terminals, clamping capacity: 1 x 0.09...1 x 1.5 mm ² AWG 28...16 flexible with cable end Screw type terminals, clamping capacity: 1 x 0.14...1 x 2.5 mm ² AWG 26...12 solid Screw type terminals, clamping capacity: 1 x 0.14...1 x 2.5 mm ² AWG 26...14 flexible without cable end Screw type terminals, clamping capacity: 2 x 0.09...2 x 0.75 mm ² AWG 28...20 flexible with cable end Screw type terminals, clamping capacity: 2 x 0.2...2 x 2.5 mm ² AWG 24...14 solid

Complementary

Supply circuit type	DC
Number of horizontal rows	2
Status LED	1 LED, green for power ON
Polarity distribution	No
Short circuit protection	2 A internal fuse, 5 x 20 mm, fast blow (PLC end)
Connector type	HE-10
Pin number	20 pins
Fixing mode	By clips on 35 mm symmetrical DIN rail By screws on solid plate with fixing kit
Supply current	<= 1.8 A
Current per channel	<= 0.5 A
Current per output common	<= 1.8 A
Voltage drop on power supply fuse	0.3 V
[U _i] rated insulation voltage	2000 V
Installation category	II conforming to IEC 60664-1
Tightening torque	0.6 N.m (with flat Ø 3.5 mm)
Width	84 mm
Product weight	0.196 kg

Environment

Product certifications	BV CSA DNV GL LROS (Lloyds register of shipping) UL
IP degree of protection	IP2x conforming to IEC 60529
Resistance to incandescent wire	750 °C conforming to IEC 60695-2-11
Shock resistance	15 gn for 11 ms conforming to IEC 60068-2-27
Vibration resistance	2 gn (f = 10...150 Hz) conforming to IEC 60068-2-6
Resistance to electrostatic discharge	4 kV (contact) conforming to IEC 61000-4-2 level 3

The information provided in this documentation contains general descriptions and/or technical characteristics of the products contained herein. This documentation is not intended as a substitute for and is not to be used for determining suitability or reliability of these products for specific user applications. It is the duty of any such user or integrator to perform the appropriate and complete risk analysis, evaluation and testing of the products with respect to the relevant specific application or use thereof. Neither Schneider Electric Industries SAS nor any of its affiliates or subsidiaries shall be responsible or liable for misuse of the information contained herein.

	8 kV (air) conforming to IEC 61000-4-2 level 3
Resistance to radiated fields	10 V/m (26000000...1000000000 Hz) conforming to IEC 61000-4-3 level 3
Resistance to fast transients	2 kV conforming to IEC 61000-4-4 level 3
Ambient air temperature for operation	-5...60 °C conforming to IEC 61131-2
Ambient air temperature for storage	-40...80 °C conforming to IEC 61131-2
Pollution degree	2 conforming to IEC 60664-1

Dimensions

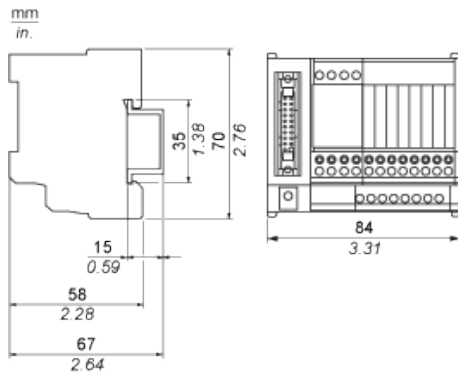

Mounting

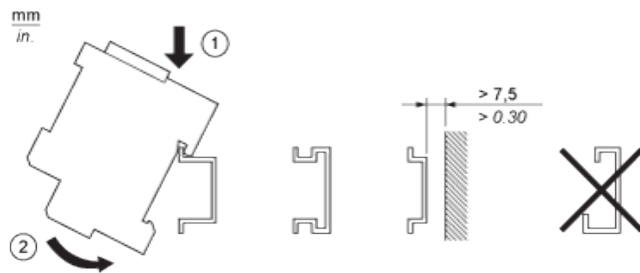

HE10 16 Channels

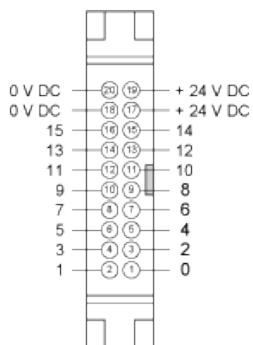

Wiring Diagrams

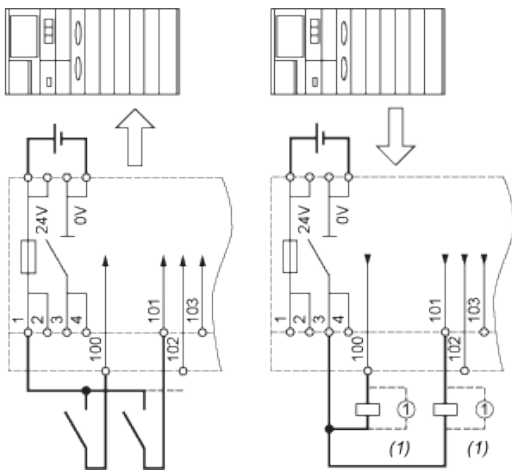

(1) Inductive load

Curves for Determining Cable Type and Length According to the Current

16-channel Sub-base

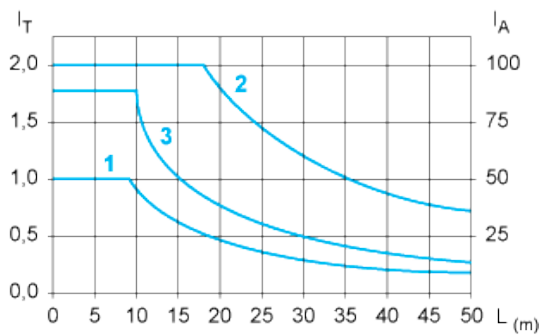

L Cable length

I_T Total current per sub base (A)

I_A Average current per channel (mA)

- (1) TSXCDP••2 and ABFH20H••0 cables with c.s.a. 0.08 mm² (AWG 28).
- (2) TSXCDP••3 cables with c.s.a. 0.34 mm² (AWG 22).
- (3) Cables with c.s.a. 0.13 mm² (AWG 26).

The curves are given for a voltage drop of 1 V in the cable. For n volts tolerance, multiply the length determined from the graph by n.