



<b>Identification</b>	Type	LD-S2-0414 AC 230 V 10 VA
	Part-No.	700414
<b>Technical data</b>		
Function type	Suppressor for Switch Gear	
Protection device	RC module	
Nominal voltage	AC 115–230 V	
Nominal voltage $U_N$	AC 230 V	
Rated frequency	50–60 Hz	
Holding Capacity	10 VA	
Type of connecting lead	LIY 0.5 mm <sup>2</sup>	
Length of connecting lead (M)	0.15 M	
Connecting lead	length 150 mm, cross section 0.5 mm <sup>2</sup>	
<b>General</b>		
Form	S2	
Pottant	2-components	
Housing material	PPO	
Protection class	IP 67	
Field installation	Insert in the rail profile or attach with retaining clips to the connection wires. (Accessories)	
Termination	Fork-type cable lug M4	
Operation temperature range	0 °C – 60 °C	
Storage temperature range	-20 °C – 80 °C	

14.11.2013 – Subject to technical modification

Part-No. 700414

USA: LUTZE INC.

13330 South Ridge Drive • Charlotte, NC 28273, USA  
 Tel. +1 (704) 504-0222 • Fax +1 (704) 504-0223  
 www.lutze.com • info@lutze.com

United Kingdom: LÜTZE Ltd.

Unit 3, Sandy Hill Park  
 Sandy Way, Amington • GB-Tamworth, Staffs B77 4DU  
 Tel. +44 (0)1827 31333-0 • Fax +44 (0)1827 31333-2  
 www.lutze.com • sales.gb@lutze.co.uk



SYSTEMATIC TECHNOLOGY

## Technical data sheet • Suppression Technology

Dimensions (w x h x d)	41.0 x 19.0 x 12.0 mm
Weight (kg/piece)	0.014
Approvals	cURus

### Dimensions

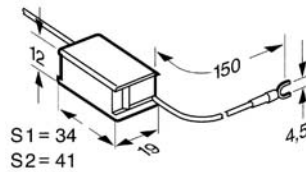

### PIN assignment



### Mounting diagram

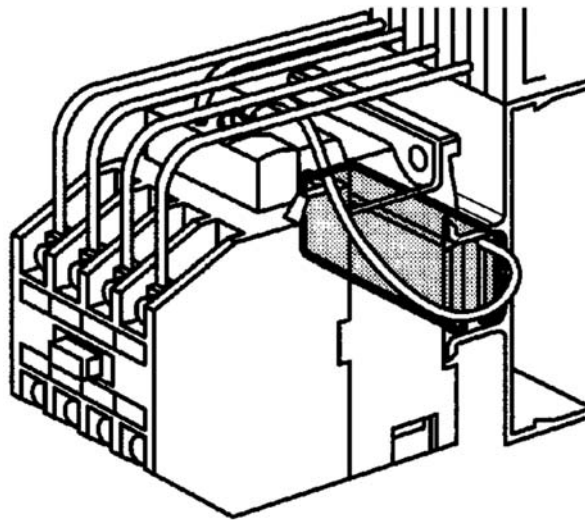

### Logo



### Accessories

Accessories	Colour	Article number	Description
Retaining clip for type S1	700409	For the mounting to the con- nection wires	100
Retaining clip for type S2	700419	For the mounting to the con- nection wires	100

14.11.2013 – Subject to technical modification

Part-No. 700414

USA: LUTZE INC.

13330 South Ridge Drive • Charlotte, NC 28273, USA  
Tel. +1 (704) 504-0222 • Fax +1 (704) 504-0223  
www.lutze.com • info@lutze.com

United Kingdom: LÜTZE Ltd.

Unit 3, Sandy Hill Park  
Sandy Way, Amington • GB-Tamworth, Staffs B77 4DU  
Tel. +44 (0)1827 31333-0 • Fax +44 (0)1827 31333-2  
www.lutze.com • sales.gb@lutze.co.uk