



■ Cable + Connectivity Solutions

# LÜTZE

## Machine and System Installation Technology

Industrial cables  
Cable assemblies  
Installation accessories  
Actuator sensor interface  
Suppression Technology

# Efficiency in Automation

Cable • Connectivity • Cabinet • Control

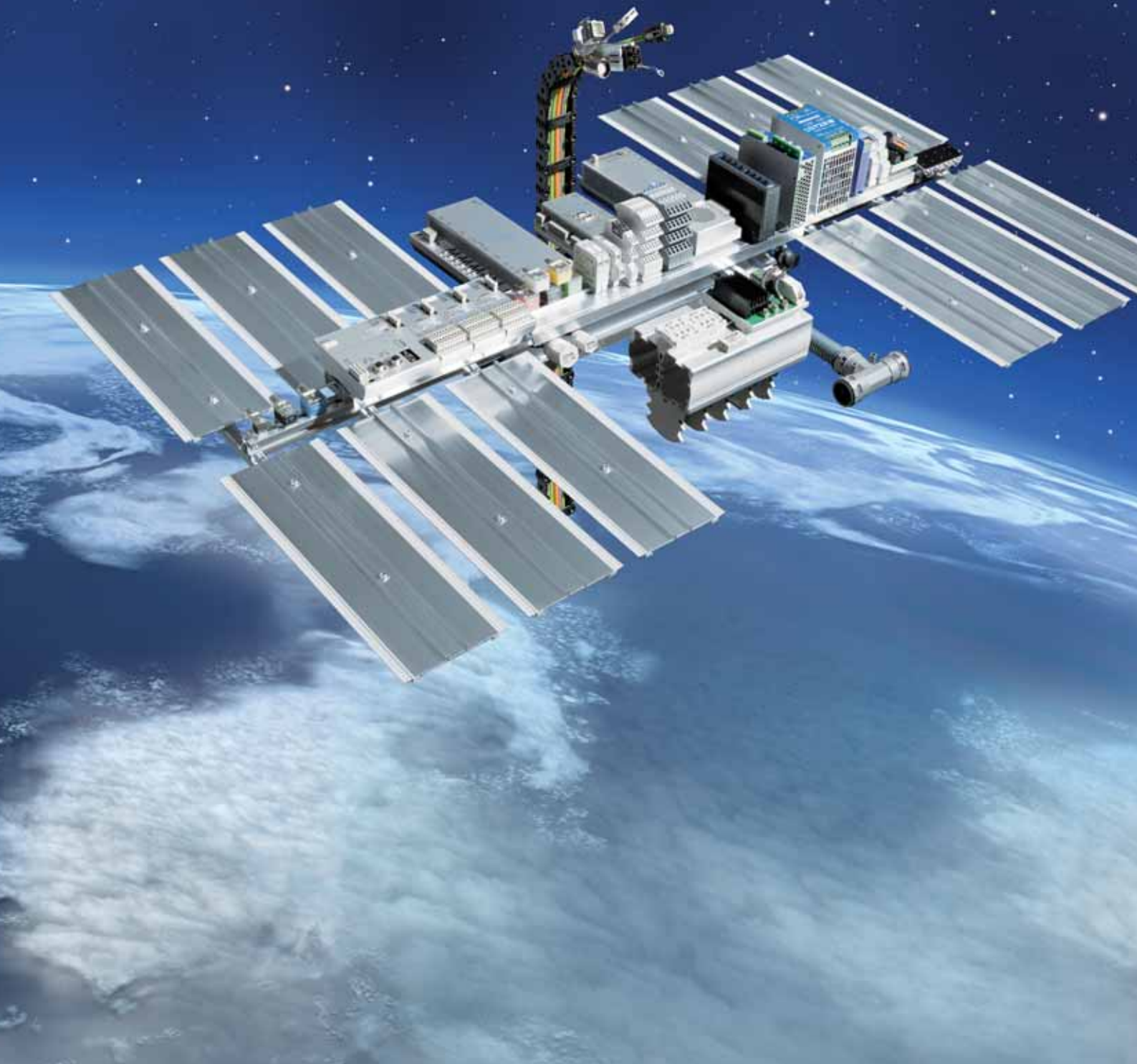

# Welcome to LÜTZE

## Cable Solutions



**Efficiency in Automation** - A reflection of our company philosophy

As an experienced specialist in automation technology, with solutions for flexible and high flexing cables, cable assemblies, interfaces, current control and cabinet wiring, we have had a focus on efficiency for many years.

## Connectivity Solutions



LÜTZE defines Efficiency in Automation field as the use of sustainable products and solutions to further increase the performance of our products in our customers applications.

We realise this by using components for highly efficient control systems, products with above average life cycles and raising energy efficiency in control cabinets by means of the LSC wiring system.

## Cabinet Solutions



Efficiency in Automation reflects our efforts in striving for efficient working relationships with our customers: in a medium sized family owned company we have short communication channels and a high level of manufacturing competence.

The value of a product or a solution from LÜTZE is determined by its sustainable qualities. Every innovation will only be successful in the future if it has a long term positive effect. Therefore, we provide long lasting as well as highly efficient components.

## Control Solutions



Thus LÜTZE creates value through efficiency. LÜTZE provides answers and demonstrates how to handle resources responsibly, with our environment and our future in mind.  
**LÜTZE - Efficiency in Automation**

For more information on our solutions, please visit [www.luetze.com](http://www.luetze.com) or [www.lutze.com](http://www.lutze.com)

## Transportation Solutions





# Business Management: Sustainable and forward



## The future is blue

Sustainable enterprise means thinking and planning ahead, understanding and embedding the belief that long lasting success is more important than short-term profit maximisation.

This is an attitude that has existed within LÜTZE for quite some time. Economic and environmental responsibilities complement each other well and are reflected in the sustainable management and

product policy - and from now in the **SkyBLUE** campaign.

We manufacture our products in a resourceful and energy-conscious manner. We use long lasting, environmentally-friendly materials.

And our products, in turn, help our customers save energy and resources.

Good for everyone: for us, for the environment, for our customers a win-win-win situation.

# ard-looking

*„The competitiveness of our industry and of its suppliers depends quite substantially on how we succeed in developing practical results. The results that we produce together today, are our competitive advantages in the future.“*

*Udo LÜTZE,*

*Member of the Executive Committee of  
the Green Carbody Innovation Alliance*



## Goods with real value

The value of a product or a solution from LÜTZE is determined by its sustainable qualities as well. Every innovation is only as successful in the future if it has a long-term positive effect. Therefore, we provide long lasting as well as highly efficient components.

We are incorporating the necessary knowledge and manufacturing competence in numerous joint projects with the objective of improving energy efficiency and

sustainable technologies and industries. Thus, LÜTZE provides answers and demonstrates how to handle resources responsibly, with our environment and our future in mind.



## RoHS



# What moves us: Quality, innovation, eff



## The people at LÜTZE

Quality, innovation and efficiency begin with people. We would not be where we are today without our highly qualified and motivated employees. An uncompromising focus on quality, nearly 60 years of experience in automation technology and of course a common desire for greater innovation and efficiency – that's what makes LÜTZE so

successful.

The people at LÜTZE are familiar with automation applications and technologies across all disciplines, as they themselves are a part of it with the LÜTZE product segments Cable, Connectivity, Cabinet and Control.



# iciency

**A prime example of competence in cables:** In addition to manufacturing expertise, our cable assembly specialists are familiar with all cable types and offer genuine added value. The decisive advantage: We're cable experts – since 1958.



# Contents



<b>Chapter 1: Control cables</b>	<b>1.1</b>
For Stationary and Flexible Applications within Machine- and Plant Wiring	1.3 - 1.5
International approvals	1.6 - 1.7
For Stationary and Flexible Applications within Machine- and Plant Wiring	
For extremely harsh operating conditions	
High oil resistance	1.8 - 1.9
Continuous Moving in Drag Chains	
For medium to high requirements	1.11 - 1.12
For high requirements	1.13 - 1.14
For highest requirements and extremely harsh operating conditions	1.15 - 1.18



<b>Chapter 2: Electronic cables</b>	<b>2.1</b>
For Stationary and Flexible Applications within Machine- and Plant Wiring	2.3 - 2.5
International approvals	2.6 - 2.8
Continuous Moving in Drag Chains	
For highest requirements	
For extremely harsh operating conditions	2.10 - 2.12



<b>Chapter 3: Actuator sensor cables</b>	<b>3.1</b>
Actuator sensor wiring	
Continuous Moving in Drag Chains	3.3 - 3.4



<b>Chapter 4: Bus and network cables</b>	<b>4.1</b>
<b>ASI BUS standard</b>	
For Stationary and Flexible Applications within Machine- and Plant Wiring	4.3
<b>Profibus standard</b>	
For Stationary and Flexible Applications within Machine- and Plant Wiring	4.4 - 4.5
Continuous Moving in Drag Chains	4.6
<b>CAN-BUS standard</b>	
For Stationary and Flexible Applications within Machine- and Plant Wiring	4.7
For highest requirements and extremely harsh operating conditions	4.8
<b>INTERBUS standard</b>	
For Stationary and Flexible Applications within Machine- and Plant Wiring	4.9
For highest requirements and extremely harsh operating conditions	4.10
<b>DeviceNet™ standard</b>	
For Stationary and Flexible Applications within Machine- and Plant Wiring	4.11
For highest requirements and extremely harsh operating conditions	4.12
<b>Industrial Ethernet/Profinet/EtherCat, Industrial Ethernet/Ethernet IP, Cat 5e, Cat 6a, Cat 7</b>	
For Stationary and Flexible Applications within Machine- and Plant Wiring	4.13
<b>Industrial Ethernet/Profinet/EtherCat, Industrial Ethernet/Ethernet IP, Cat 5e, Cat 6</b>	
Continuous Moving in Drag Chains	
For highest requirements and extremely harsh operating conditions	4.14





<b>Chapter 5: Motor, Servo and Feedback cables</b>	<b>5.1</b>
PVC Motor, Connection-, Power Supply Cable	5.3 - 5.4
Motor Cable for Frequency Converter	5.5
Connection-, Power Supply Cable for Siemens* and other Systems	5.6
Feedback cable for Siemens DRIVE-CLIQ 6FX5008 Standard*	5.7
<b>PUR Motor and Servo cables, c-track compatible</b>	
Continuous Moving in Drag Chains	
Acc. to standards: Siemens*, Bosch Rexroth*, Lenze*, SEW*, Hiperface DSL®, Single Conductor for Motor wiring	5.9 - 5.16
<b>Feedbackleitungen, c-track compatible</b>	
Continuous Moving in Drag Chains	
Acc. to standards: Siemens*, Bosch Rexroth*, Lenze*, SEW*, Allen-Bradley* Heidenhain* and various Systems	5.17 - 5.23
<b>Chapter 6: Cable assemblies</b>	<b>6.1</b>
Customer specific solutions with LÜTZE Tamper-proof connector	6.4 - 6.5
<b>Assemblies for servo drive systems</b>	
Allen-Bradley*	6.6 - 6.10
Bosch Rexroth*	6.11 - 6.13
Lenze*	6.14 - 6.15
SEW*	6.16 - 6.18
SIEMENS*	6.19 - 6.33
<b>Pre-assembled cables</b>	
SIEMENS Simatic*, Patch cable Cat.5E/Cat.6	
USB 3.0 connection cables, Coil cables	6.34 - 6.37
<b>Chapter 7: Actuator sensor interface</b>	<b>7.1</b>
Actuator sensor cables / Actuator sensor valve suppressors	7.4 - 7.47
Connectors, assembled freely	7.48 - 7.64
Panel connectors	7.65 - 7.70
Accessories	7.71 - 7.72
Classification Ethernet Cable and - connector	7.73
<b>Chapter 8: Suppression technology</b>	<b>8.1</b>
Suppressor for Switching Gear	8.3 - 8.10
Valve connectors	8.11 - 8.36
Motor suppression	8.37 - 8.46
Components with special function	8.47
<b>Chapter 9: Installation Accessories</b>	<b>9.1</b>
<b>Chapter 10: EMC accessories</b>	<b>10.1</b>
<b>Chapter 11: Technical information</b>	<b>11.1</b>



# Contents

## 1 Control cables

LÜTZE SILFLEX® B PVC	1.3
LÜTZE SILFLEX® N PVC	1.4
LÜTZE SILFLEX® N (C) PVC	1.5
LÜTZE SILFLEX® N PVC MULTINORM	
With approvals for Europe and North America	1.6
LÜTZE SILFLEX® N (C) PVC MULTINORM	
With approvals for Europe and North America	1.7
LÜTZE SILFLEX® N PUR	1.8
LÜTZE SILFLEX® N (C) PUR	1.9
LÜTZE SUPERFLEX® N PVC	
For medium to high requirements	1.11
LÜTZE SUPERFLEX® N (C) PVC	
For medium to high requirements	1.12
LÜTZE SUPERFLEX® N PVC	
For high requirements	1.13
LÜTZE SUPERFLEX® N (C) PVC	
For high requirements	1.14
LÜTZE SUPERFLEX® PLUS N PUR 300 V	
For highest requirements	1.15
LÜTZE SUPERFLEX® PLUS N PUR 600 V	
For highest requirements	1.16
LÜTZE SUPERFLEX® PLUS N (C) PUR 300 V	
For highest requirements	1.17
LÜTZE SUPERFLEX® PLUS N (C) PUR 600 V	
For highest requirements	1.18

## 2 Electronic cables

LÜTZE ELECTRONIC LiYY	
unshielded Electronic cable	2.3
LÜTZE ELECTRONIC LiY (C) Y	
shielded Electronic cable	2.4
LÜTZE ELECTRONIC LiY (C) Y TP	
Shielded electronic cable, paired	2.5
LÜTZE ELECTRONIC LiYY	
Unshielded electronic cable UL recognized	2.6
LÜTZE ELECTRONIC LiY (C) Y	
Shielded electronic cable UL recognized	2.7
LÜTZE ELECTRONIC LiY (C) Y TP	
Shielded electronic cable UL recognized, paired	2.8
LÜTZE SUPERFLEX® TRONIC PUR	
Unshielded electronic cable UL recognized	2.10
For highest requirements	
LÜTZE SUPERFLEX® TRONIC (C) PUR	
Shielded electronic cable UL recognized	2.11
For highest requirements	
LÜTZE SUPERFLEX® TRONIC (C) PUR TP	
Shielded electronic cable UL recognized, paired	2.12
For highest requirements	

## 3 Actuator sensor cables

LÜTZE SUPERFLEX® TRONIC AS PUR, unshielded	
For highest requirements	3.3
LÜTZE SUPERFLEX® TRONIC AS (C) PUR, shielded	
For highest requirements	3.4

## 4 Bus and network cables

LÜTZE ELECTRONIC ASI BUS TPE	4.3
LÜTZE ELECTRONIC Profibus (C) PVC	4.4
LÜTZE ELECTRONIC Profibus (C) PVC	4.5
LÜTZE SUPERFLEX® Profibus (C) PUR	
For highest requirements	4.6
LÜTZE ELECTRONIC CAN-BUS (C) PVC	4.7
LÜTZE SUPERFLEX® CAN-BUS (C) PUR	
For highest requirements	4.8
LÜTZE ELECTRONIC INTERBUS (C) PVC	4.9
LÜTZE SUPERFLEX® INTERBUS (C) PUR	4.10
LÜTZE ELECTRONIC DeviceNet™ (C) PVC	4.11

LÜTZE SUPERFLEX® DeviceNet™ (C) PUR	
For highest requirements	4.12
LÜTZE ELECTRONIC ETHERNET (C) PVC	4.13
LÜTZE SUPERFLEX® ETHERNET (C) PUR	
For highest requirements	4.14

## 5 Motor, servo and feedback cables

LÜTZE SILFLEX® M PVC 0,6/1 kV	
Motor/connecting/power supply cable	5.3
LÜTZE SILFLEX® M (C) PVC 0,6/1 kV	
Shielded motor/connecting/power supply cable	5.4
LÜTZE SILFLEX® M XLPE 3 (C) PVC 0,6/1 kV	
2XSL(ST)CY-JB motor connecting cable for frequency converter	5.5
LÜTZE SILFLEX® M (C) PVC SERVO 0.6/1 kV	
Motor/energy supply cable for Siemens and other systems	5.6
LÜTZE SILFLEX® (C) PVC FEEDBACK	
Feedback cable for Siemens DRIVE-CLIQ 6FX5008 standard system	5.7
LÜTZE SUPERFLEX® PLUS M PUR 0.6/1 kV	
Motor/energy supply cable	
For highest requirements	5.9
LÜTZE SUPERFLEX® PLUS M (C) PUR SERVO 0.6/1 kV	
Supply line for Siemens and other systems	
For highest requirements	5.10
LÜTZE SUPERFLEX® PLUS M (C) PUR SERVO 0.6/1 kV	
Supply line for Bosch-Rexroth and other systems	
For highest requirements	5.11
LÜTZE SUPERFLEX® PLUS M (C) PUR SERVO 0.6/1 kV	
Supply line for Lenze and other systems	
For highest requirements	5.12
LÜTZE SUPERFLEX® PLUS M (C) PUR SERVO 0.6/1 kV	
Supply line for SEW and other systems	
For highest standards	5.13
LÜTZE SUPERFLEX® PLUS M (C) PUR HYBRID SERVO 0,6/1 kV	
combined power supply cable for servo motors with Hiperface DSL® interface	
For the highest of standards	5.14
LÜTZE SUPERFLEX® PLUS PUR 0.6/1 kV	
Motor/energy supply cable	
For highest requirements	5.15
LÜTZE SUPERFLEX® PLUS (C) PUR 0.6/1 kV	
Motor/energy supply cable, for highest requirements	5.16
LÜTZE SUPERFLEX® PLUS (C) PUR FEEDBACK	
Encoder cables for Siemens and other systems	
For highest requirements in drive technology	5.17
LÜTZE SUPERFLEX® PLUS (C) PUR FEEDBACK	
Feedback cables for Bosch-Rexroth and other systems	
For highest requirements in drive technology	5.18
LÜTZE SUPERFLEX® PLUS (C) PUR FEEDBACK	
Feedback cables for Lenze and other systems	
For highest requirements in drive technology	5.19
LÜTZE SUPERFLEX® PLUS (C) PUR FEEDBACK	
Feedback cables for SEW and other systems	
For highest requirements in drive technology	5.20
LÜTZE SUPERFLEX® PLUS (C) PUR FEEDBACK	
Feedback cables for Allen-Bradley and other systems	
For highest requirements in drive technology	5.21
LÜTZE SUPERFLEX® PLUS (C) PUR FEEDBACK	
Feedback cables for Heidenhain and other systems	
For highest requirements in drive technology	5.22
LÜTZE SUPERFLEX® PLUS (C) PUR FEEDBACK	
Feedback cables for various systems	
For highest requirements in drive technology	5.23

## 6 Cable assemblies

According to Allen-Bradley 2090 standard	6.6
According to Allen-Bradley 2090 standard	6.7
According to Allen-Bradley 2090 standard	6.8
According to Allen-Bradley 2090 standard	6.9

# Contents

According to Allen-Bradley 2090 standard	6.10	self-locking screwed connection	7.11
According to Bosch Rexroth IKG standard	6.11	c-track compatible, halogen free	7.11
According to Bosch Rexroth RKL standard	6.12	Male-female M12 straight with PUR cable, shielded 360°	7.12
According to Bosch Rexroth IKS standard	6.13	self-locking screwed connection	7.12
According to LENZE-Standard	6.14	c-track compatible, halogen free	7.12
According to LENZE-Standard	6.15	Male M12 straight with PUR cable, shielded 360°, open end	7.13
According to SEW standard		self-locking screwed connection	7.13
base and extension cables	6.16	c-track compatible, halogen free	7.13
According to SEW standard		Male M12 straight on male M12 straight with PUR cable, shielded 360°	7.14
base and extension cables	6.17	self-locking screwed connection	7.14
According to SEW standard	6.18	c-track compatible, halogen free	7.14
Acc. to SIEMENS-6FX5002 standard		Male M8 straight with PUR cable, open end	7.15
Base cable	6.19	self-locking screwed connection	7.15
Acc. to SIEMENS-6FX5002 standard		c-track compatible, halogen free	7.15
Base cable	6.20	Male M8 straight with PUR cable, shielded 360°, open end	7.16
Acc. to SIEMENS-6FX5002 standard		self-locking screwed connection	7.16
Base cable	6.21	c-track compatible, halogen free	7.16
Acc. to SIEMENS-6FX5002 standard		Female M8 straight with PUR cable, open end	7.17
Base cable	6.22	self-locking screwed connection	7.17
Acc. to SIEMENS-6FX5002 standard		c-track compatible, halogen free	7.17
Extension	6.23	Female M8 straight with PUR cable, shielded 360°, open end	7.18
Acc. to SIEMENS-6FX5002 standard		self-locking screwed connection	7.18
Extension	6.24	c-track compatible, halogen free	7.18
According to SIEMENS-6FX5002 standard		Female M8 angled with PUR cable, open end	7.19
Base cable DRIVE-CLIQ®	6.25	self-locking screwed connection	7.19
Acc. to SIEMENS-6FX8002 standard		c-track compatible, halogen free	7.19
Base cable	6.26	Female M8 angled with PUR cable, shielded 360°, open end	7.20
Acc. to SIEMENS-6FX8002 standard		self-locking screwed connection	7.20
Base cable	6.27	c-track compatible, halogen free	7.20
Acc. to SIEMENS-6FX8002 standard		Female M8 angled with 2 LED's and PUR cable, open end	7.21
Base cable	6.28	self-locking screwed connection	7.21
Acc. to SIEMENS-6FX8002 standard		c-track compatible, halogen free	7.21
Base cable	6.29	Male M8 straight to female M8 straight with PUR cable	7.22
Acc. to SIEMENS-6FX8002 standard		self-locking screwed connection	7.22
Extension	6.30	c-track compatible, halogen free	7.22
Acc. to SIEMENS-6FX8002 standard		Male M8 straight to female M8 angled with PUR cable	7.23
Extension	6.31	self-locking screwed connection	7.23
Acc. to SIEMENS-6FX8002 standard		c-track compatible, halogen free	7.23
Base cable DRIVE-CLIQ®	6.32	Male M12 straight with PUR cable, open end	7.24
S7 Plug		self-locking screwed connection	7.24
For Siemens Simatic PLC/S7	6.34	c-track compatible, halogen free	7.24
Patch cable Cat 5E / Cat 6	6.35	Male M12 straight with PUR cable, open end	7.25
USB 3.0 connection cables	6.36	self-locking screwed connection	7.25
LÜTZE PURFLEX	6.37	c-track compatible, halogen free	7.25
		Male M12 straight with PUR cable, shielded 360°, open end	7.26
		self-locking screwed connection	7.26
		c-track compatible, halogen free	7.26
		Male M12 straight with PUR cable, shielded 360°, open end	7.27
		self-locking screwed connection	7.27
		c-track compatible, halogen free	7.27
		Female M12 straight with PUR cable, open end	7.28
		self-locking screwed connection	7.28
		c-track compatible, halogen free	7.28
		Female M12 straight with PUR cable, open end	7.29
		self-locking screwed connection	7.29
		c-track compatible, halogen free	7.29
		Female M12 straight with PUR cable, shielded 360°, open end	7.30
		self-locking screwed connection	7.30
		c-track compatible, halogen free	7.30
		Female M12 straight with PUR cable, shielded 360°, open end	7.31
		self-locking screwed connection	7.31
		c-track compatible, halogen free	7.31
		Female M12 angled with PUR cable, open end	7.32
		self-locking screwed connection	7.32
		c-track compatible, halogen free	7.32
		Female M12 angled with PUR cable, open end	7.33
		self-locking screwed connection	7.33
		c-track compatible, halogen free	7.33
<b>7 Actuator sensor interface</b>			
Male M12 straight with PUR cable, shielded 360°, open end	7.4		
self-locking screwed connection	7.4		
c-track compatible, halogen free	7.4		
Female M12 straight with PUR cable, shielded 360°, open end	7.5		
self-locking screwed connection	7.5		
c-track compatible, halogen free	7.5		
Male-female M12 straight with PUR cable, shielded 360°	7.6		
self-locking screwed connection	7.6		
c-track compatible, halogen free	7.6		
Male M12 straight with PUR cable, shielded 360°, open end	7.7		
self-locking screwed connection	7.7		
c-track compatible, halogen free	7.7		
Female M12 straight with PUR cable, shielded 360°, open end	7.8		
self-locking screwed connection	7.8		
c-track compatible, halogen free	7.8		
Male-female M12 straight with PUR cable, shielded 360°	7.9		
self-locking screwed connection	7.9		
c-track compatible, halogen free	7.9		
Male M12 straight with PUR cable, shielded 360°, end open	7.10		
self-locking screwed connection	7.10		
c-track compatible, halogen free	7.10		
Female M12 straight with PUR cable, shielded 360°, end open	7.11		

# Contents

Female M12 angled with PUR cable, shielded 360°, open end self-locking screwed connection	7.34	Field wireable connector, M12 straight shielded	7.56
c-track compatible, halogen free	7.34	Male / female - A coded (CAN)	7.56
Female M12 angled with PUR cable, shielded 360°, open end self-locking screwed connection	7.35	Screw terminal	7.56
c-track compatible, halogen free	7.35	Field wireable connector, M12 shielded	7.57
Female M12 angled, with LEDs and PUR cable, open end self-locking screwed connection	7.36	Female angle connector - A coded Cat 5e	7.57
c-track compatible, halogen free	7.36	IDC quick-connect technology	7.57
Male M12 straight to female M8 straight with PUR cable self-locking screwed connection	7.37	Field wireable connector, M12 straight shielded	7.58
c-track compatible, halogen free	7.37	Male / female - B coded (Profibus, Interbus)	7.58
Male M12 straight to female M12, straight with PUR cable self-locking screwed connection	7.38	Screw terminal	7.58
c-track compatible, halogen free	7.38	Field wireable connector, M12 straight shielded	7.59
Male M12 straight to female M12 straight with PUR cable self-locking screwed connection	7.39	Male - D coded Cat 5e (Ethernet, Profinet)	7.59
c-track compatible, halogen free	7.39	Screw terminal	7.59
Male M12 straight to female M12 angled with PUR cable self-locking screwed connection	7.40	Field wireable connector, M12 straight shielded	7.60
c-track compatible, halogen free	7.40	Male - X coded Cat 6A (Ethernet, Profinet)	7.60
Male M12 straight to female M12 angled with PUR cable self-locking screwed connection	7.41	IDC quick-connect technology	7.60
c-track compatible, halogen free	7.41	Field wireable connector, M12 straight shielded	7.61
Male M12 straight to female M12 angled with PUR cable and 360° shielding	7.42	Female - D coded Cat 5e (Ethernet, Profinet)	7.61
self-locking screwed connection	7.42	Shield termination via iris spring, cage clamp	7.61
c-track compatible, halogen free	7.42	Industrial connector RJ45	7.62
Male M12 straight to female M12 angled with LEDs and PUR cable	7.43	solid metal housing, quick-connect technology AWG 27–22	7.62
self-locking screwed connection	7.43	Cat 6A	7.62
c-track compatible, halogen free	7.43	Industrial connector RJ45, angled	7.63
Male M12 straight to valve connector form A	7.44	solid metal housing, quick-connect technology AWG 27–22	7.63
with protection device and LED status indication	7.44	Cat 6A	7.63
c-track compatible, halogen free	7.44	Module holder, RJ45, female / IDC	7.64
Male M12 straight to valve connector form A for pressure switch	7.45	For TS35 DIN rail	7.64
with LED status indication	7.45	Cat 6	7.64
c-track compatible, halogen free	7.45	M8 panel connectors using M8 thread	7.65
Male M12 straight to valve suppressor form B / form BI	7.46	Male / female	7.65
with protection device and LED status indication	7.46	0.5 m TPE wire	7.65
c-track compatible, halogen free	7.46	M12 connectors panel mounted using M16 thread	7.66
Male M12 straight to valve suppressor form C / form CI	7.47	Male / female - A coded	7.66
with protection device and LED status indication	7.47	0.5 m TPE wire	7.66
c-track compatible, halogen free	7.47	USB 3.0 panel connector with M22 thread for front installation	7.67
field wireable connector, M8 straight	7.48	USB connector Type A on straight USB plug Type A with PVC cable	7.67
Male / female	7.48	Type: USB-3.0 A/A	7.67
Screw terminal	7.48	USB 3.0 panel connector with M22 thread for front installation	7.68
field wireable connector, M8 straight	7.49	USB 3.0 Female / Female Type A/A	7.68
Male / female	7.49	Typ: UBS-3.0 A/A F/F	7.68
IDC quick-connect technology	7.49	RJ45 panel connector for front installation 22.5 mm	7.69
field wireable connector, M12 straight	7.50	female/female 1:1	7.69
Male - A coded	7.50	Cat 5e/6	7.69
Screw terminal	7.50	Control cabinet bushing M12 - RJ45	7.70
field wireable connector, M12 straight	7.51	female/female 1:1	7.70
Female - A coded	7.51	Cat 5e (Ethernet, Profinet)	7.70
Screw terminal	7.51	Protective coverage	7.71
field wireable connector, M12 angled	7.52	M8, M12	7.71
Male - A coded	7.52	Color: black	7.71
Screw terminal	7.52	Designation unit for M8, M12 cables	7.72
Field wireable connector, M12 angled	7.53	Designation plate, designation sleeve	7.72
Female - A coded	7.53	Color: white, transparent	7.72
Screw terminal	7.53		
Field wireable connector, M12 straight	7.54	<b>8 Suppression Technology</b>	
Male / female - A coded	7.54	Universal Suppressor Module	8.3
Fast connection method, IDC method of termination	7.54	Enclosure type: S7A	8.3
T piece	7.55	Protection device: RC combination	8.3
Male M12 to 2× female M12, 5pin PIN 2+4 bridged + PE	7.55	Universal Suppressor Module	8.4
Male M12 4pin to 2× female M8, 3pin	7.55	Enclosure type: S1, S2	8.4
		Protection device: Diode / Varistor / RC module	8.4
		Universal Suppressor Module	8.5
		Enclosure type: V1	8.5
		Protection device: Diode / Varistor / RC module	8.5
		Universal Suppressor Module	8.6
		Enclosure type: VM1, V2	8.6
		Protection device: RC module	8.6
		Universal suppressor module - for Siemens-, AEG-, EATON contactors	8.7
		Enclosure type S6	8.7
		Protection device: Diode / Varistor / RC module	8.7

# Contents

Universal suppressor module - switch size S00 - for Siemens switches 3RT1015-/3RT1016-/3RT1017-/3RH1122-/3RH1131-/3RH1140- Protection device: Diode / Varistor / RC module	8.8	Ground wire terminator (PE) adjustable in 180° steps Construction A (18 mm) adjustable plug	8.28
Universal suppressor module - switch size S00 - for Siemens switches 3RT1015-/3RT1016-/3RT1017-/3RH1122-/3RH1131-/3RH1140- Protection device: Diode + LED / Varistor + LED	8.9	Pressure switch / fill level monitor Adjustable male, form A (18 mm) Switching amplifier with and without galvanic insulation	8.29
Universal suppressor module for Siemens switches 3RT102 (S0), 3RT103 (S2), 3RT 104 (S3) Enclosure type: S12, S13	8.10	Ground wire terminator, short-circuit-proof, 0°–180° installation Adjustable male, form A (18 mm)	8.30
Protection device: Varistor / RC module with integrated protection device + LED	8.10	- Double valves - Energy reducer	8.31
2pin version, protected against reverse polarity, moulded PUR connecting cable 2 × 0.75 mm2	8.11	Adjustable plug; Construction A (18 mm) - two cable entry points	8.32
on cable outlet can be directly mounted to a protective hose with integrated protection device + LED	8.11	Ground wire terminator (PE) adjustable in 180° steps Adjustable male, form B DIN (10 mm) and BI (11 mm)	8.32
protection against reverse polarity, moulded single conductor PVC FLRY 2 × 0.75 mm2	8.12	Ground wire terminator (PE) adjustable in 180° steps by turning the coding disk	8.33
on cable outlet can be directly mounted to a protective hose with integrated protection device + LED	8.12	Protection device: without circuit / Z-Diode+LED / Varistor+LED	8.33
2-pin style, protection against reverse polarity Moulded PUR connecting cable 2 × 0.75 mm2	8.13	Adjustable plug Construction B (10 mm) and BI (11 mm)	8.34
2-pole straight	8.14	Ground wire terminator (PE) adjustable in 180° steps Adjustable connector, Construction B (10 mm), Construction BI (11 mm)	8.34
Protection device suppressor diode + status indication LED with moulded vehicle cable Type FLRY as single conductor 0.75 mm2	8.14	Switching amplifier without galvanic insulation short circuit protection	8.35
Construction A (18 mm)	8.15	Ground wire terminator (PE) adjustable in 180° steps Adjustable male, form C DIN (8 mm) and CI (9.4 mm)	8.35
2pin version, protected against reverse polarity, moulded PUR connecting cable 2 × 0.75 mm2	8.15	Ground wire terminator (PE) adjustable in 90° steps by turning the coding disk	8.36
Protection device: suppressor diode + LED Design A (18 mm), 2-pin without PE	8.16	Protection device: without circuit / Z-Diode+LED / Varistor+LED	8.36
Protection device suppressor diode + LED, with stainless steel screw	8.16	Plug adaptor for valve suppressors type A Contact clearance 18 mm	8.37
Moulded vehicle cable Type FLRY as single conductor 2x0.75mm2 Design A (18mm), 3-pin without PE, 0°	8.17	EN 175301-803 (DIN 43 650) Plug adaptor for valve suppressors type BI (11 mm)	8.37
Without circuit, with stainless steel screw	8.17	Contact arrangement in 0° and 180° construction	8.38
with moulded vehicle cable Type FLRY as single conductor 3x0.75mm2	8.17	Motor suppression for the direct installation in the motor junction plate	8.39
Construction A (18 mm)	8.18	5.5 kW to 7.5 kW, 3 AC x 500 V	8.39
PVC connecting lead	8.18	Protection device: Varistor	8.39
with bridged ground conductor (PE)	8.18	Motor suppression for the screwing in in the motor terminal box also suitable for frequency converters up to 7.5 kW, 3 AC x 575 V	8.40
Construction A (18 mm)	8.19	Protection device: Varistor	8.40
PUR connecting lead	8.19	Motor suppression for the direct installation in the motor junction plate	8.41
with bridged ground conductor (PE)	8.19	7.5 kW, 3 AC x 500 V	8.41
Energy reducer, construction A (18 mm), PUR cable	8.20	Protection device: RC module	8.41
Energy reduction approx. 50 %, protection device, LED status indication	8.20	Motor suppression for the screwing in in the motor terminal box up to 7.5 kW, 3 AC x 575 V	8.42
0° – 180° field installation, open cable end	8.20	Protection device: RC module	8.42
Construction A (18 mm)	8.21	Motor suppression in the M1, M2 and M3 enclosure for AC motors up to 30 kW, 3 AC x 500 V	8.43
PUR connecting lead	8.21	Protection device: RC module	8.43
Pressure switch / fill level monitor	8.21	Universal motor suppression: direct attachment to the switch (e.g. Siemens SIRIUS 3RT 10)	8.44
Construction A (18 mm)	8.22	Protection device: Varistor	8.44
PUR connecting lead	8.22	As substructure for protection types up to 45 mm wide	8.45
Switching amplifier, short-circuit-proof, 0°–180° installation	8.22	2.5 kW, 3 AC x 400 V	8.45
Construction B (10 mm)	8.23	Protection device: Varistor	8.45
PUR/PVC cable	8.23	As substructure for protection types up to 45 mm wide up to 15 kW, 3 AC x 575 V	8.46
Protection device: suppressor diode + LED	8.23	Protection device: RC module	8.46
Construction BI (11 mm)	8.24	Adjustable switch-on delays, time range 0.5 s - 20 s	8.47
PUR/PVC cable	8.24	Enclosure type: S2, V1	8.47
Protection device: suppressor diode + LED	8.24	for AC and DC operation	8.47
Construction C (8 mm)	8.25		
PUR/PVC cable	8.25		
with bridged ground conductor (PE)	8.25		
Construction CI (9.4 mm)	8.26		
PUR/PVC cable	8.26		
with bridged ground conductor (PE)	8.26		
Adjustable male, design A (18 mm)	8.27		
Ground wire terminator (PE) adjustable in 90° steps by turning the coding disk	8.27		
Protection device: without circuit / Z-Diode+LED / Varistor+LED	8.27		
Adjustable plug	8.28		
Construction A (18 mm)	8.28		

## 9 Installation accessories

Cablefix Vario	
Feed-through for all prefabricated cables and wires with connectors	9.3
Cablefix Vario	
Feed-through for all prefabricated cables and wires with connectors	9.4
Cablefix flanges	9.5
Plastic fittings TOP-T-P, metric version	9.6

# Contents

Plastic fittings TOP-T-P, PG version	9.7
Plastic fitting TOP-TR-P	9.8
Plastic accessory locknut GK, metric version	9.9
Plastic accessory locknut GK, PG version	9.10
Plastic accessory reducing ring RR, metric	9.11
Plastic accessory Blank plug BL	9.12
Metal fitting TOP-T	9.13
Metal fitting TOP-TR	9.14
Metal fitting with shield termination TOP-T-S-EMV1	9.15
Metal fitting with shield termination TOP-T-S-EMV2	9.16
Metal accessory Locknut GMS	9.17
Metal accessory Locknut GMS EMC	9.18
Metal accessory reducing ring RR	9.19
Metal accessory expansion EW	9.20
Metal accessory blank plug BLMS	9.21
Plastic and metal accessory multiple sealing insert MFDE	9.22
Plastic and metal accessory sealing insert ASI DE	9.23
Control panel installation	9.24
Cable tie	9.25
Identification of hook-up wires and cables	9.26
Laser labels	9.27
Marker strips	9.28
<b>10 EMC accessories</b>	
EMC shield rail	10.3
EMC shield rail with cable clamping options for a wide variety of shield clamps	10.3
Mounting bracket	10.4
Mounting bracket for fastening the EMC rail in the control cabinet	10.4
EMC shield rail	10.5
EMC shield rail with cable clamping options for a wide variety of shield clamps	10.5
Bracket	10.6
Retaining bracket for fastening the EMC rail	10.6
Shield clamp	10.7
Spring shield clamp	10.8
Shield connection for large-diameter cables	10.8
Snap-on element for snapping onto hat rail for attaching a screening clamp	10.9
Snap-on element can be snapped onto LSC profiles	10.10
Earthing strip, copper braiding, tin-plated	10.11
Single wire Cu ETP UNI 5649-71, similar to DIN 72333	10.11
Earthing strip, copper braiding, tin-plated	10.12
Single wire Cu ETP UNI 5649-71, similar to DIN 72333	10.12
Cable clip	10.13
<b>11 Technical information</b>	
<b>12 Article Number index</b>	

**Our General Terms of Business and Terms of Payment shall apply for all contracts and orders (AGBs).**

**You can find these on our homepage at [www.luetze.com](http://www.luetze.com)**



# 1. Control cables

	Jacket	Shielding	Approval	Application	
<b>LÜTZE SILFLEX® B PVC</b>	PVC		CE	For Stationary and Flexible Applications within Machine- and Plant Wiring	1.3
<b>LÜTZE SILFLEX® N PVC</b>	PVC		CE	For Stationary and Flexible Applications within Machine- and Plant Wiring	1.4
<b>LÜTZE SILFLEX® N (C) PVC</b>	PVC	•	CE	For Stationary and Flexible Applications within Machine- and Plant Wiring	1.5
<b>LÜTZE SILFLEX® N PVC MULTINORM</b>	PVC		CE, UL, VDE	For Stationary and Flexible Applications within Machine- and Plant Wiring International approvals	1.6
<b>LÜTZE SILFLEX® N (C) PVC MULTINORM</b>	PVC	•	CE, UL, VDE	For Stationary and Flexible Applications within Machine- and Plant Wiring International approvals	1.7
<b>LÜTZE SILFLEX® N PUR</b>	PUR		CE	For Stationary and Flexible Applications within Machine- and Plant Wiring For extremely harsh operating conditions High oil resistance	1.8
<b>LÜTZE SILFLEX® N (C) PUR</b>	PUR	•	CE	For Stationary and Flexible Applications within Machine- and Plant Wiring For extremely harsh operating conditions High oil resistance	1.9
<b>LÜTZE SUPERFLEX® N PVC</b>	PVC		CE	Continuous Moving in Drag Chains For medium to high requirements	1.11
<b>LÜTZE SUPERFLEX® N (C) PVC</b>	PVC	•	CE	Continuous Moving in Drag Chains For medium to high requirements	1.12
<b>LÜTZE SUPERFLEX® N PVC</b>	PVC		CE, UL	Continuous Moving in Drag Chains For high requirements	1.13
<b>LÜTZE SUPERFLEX® N (C) PVC</b>	PVC	•	CE, UL	Continuous Moving in Drag Chains For high requirements	1.14
<b>LÜTZE SUPERFLEX® PLUS N PUR 300 V</b>	PUR		CE, UL	Continuous Moving in Drag Chains For highest requirements and extremely harsh operating conditions	1.15
<b>LÜTZE SUPERFLEX® PLUS N PUR 600 V</b>	PUR		CE, UL	Continuous Moving in Drag Chains For highest requirements and extremely harsh operating conditions	1.16
<b>LÜTZE SUPERFLEX® PLUS N (C) PUR 300 V</b>	PUR	•	CE, UL	Continuous Moving in Drag Chains For highest requirements and extremely harsh operating conditions	1.17
<b>LÜTZE SUPERFLEX® PLUS N (C) PUR 600 V</b>	PUR	•	CE, UL	Continuous Moving in Drag Chains For highest requirements and extremely harsh operating conditions	1.18



# PVC control cables · unshielded

## LÜTZE SILFLEX® B PVC



### Application

- Machine and device construction, transport and conveyor technology, HVAC technology
- In dry and damp rooms
- As a monitoring, measurement and control cable for industrial applications
- For flexible application without continuous flexing

### Properties

- PVC Flame-retardant, self-extinguishing
- Resistant to most oils, greases, acids and alkalis
- Silicone free
- RoHS-compliant

### Technical data

Voltage	
U <sub>0</sub> /U	300/500 V
Test voltage	4000 V
Insulation resistance	min. 20 MΩ × km
Temperature range	
moving	-15 °C to +70 °C
fixed	-40 °C to +80 °C
Minimum bending radius	
moving	D × 10
fixed	D × 4
Burning behavior	Flame-retardant according to VDE 0482 Part 265-2, DIN EN 50265-2, IEC 60332-1

### Construction

- Bare copper wire, finely stranded according to DIN VDE 0295 class 5, IEC 60228 class 5
- Conductor insulation Special PVC TI2 according to VDE 0281-1
- Colored according to DIN VDE 0293-308
- 2-wire: brown, blue
- 3-wire: greenyellow, brown, blue
- 4-wire: greenyellow, brown, black, grey
- 5-wire: greenyellow, brown, blue, black, grey
- Ground conductor green/yellow according to DIN EN 50334 in the top layer
- G = with green/yellow ground conductor, × = without ground conductor
- Conductors cabled in layers
- Jacket special PVC TM2 according to VDE 0281-1, matte, adhesion-free surface
- Jacket color grey RAL 7001

Part-No.	Number of conductors/cross-section	Outer Ø ca. mm	Weight kg/100 m	Cu-Index kg/100 m
<b>0.5 mm<sup>2</sup></b>				
100013	2×0.5	4.9	3.5	0.9
100001	3G0.5	5.2	4.1	1.4
100002	4G0.5	5.8	5.0	2.2
<b>0.75 mm<sup>2</sup></b>				
100024	2×0.75	5.3	4.3	1.4
100025	3G0.75	5.8	5.4	2.2
100012	3×0.75	5.8	5.4	2.2
100026	4G0.75	6.4	6.6	2.9
100027	5G0.75	6.9	8.0	3.6
<b>1.0 mm<sup>2</sup></b>				
100050	2×1.0	5.6	5.0	1.9
100051	3G1.0	6.2	6.4	2.9
100983	3×1.0	6.2	6.4	2.9
100052	4G1.0	6.7	7.7	3.8
100053	5G1.0	7.3	9.4	4.8
<b>1.5 mm<sup>2</sup></b>				
100079	3G1.5	6.8	8.1	4.3
100080	4G1.5	7.4	10.0	5.8
100081	5G1.5	8.3	12.5	7.2
<b>2.5 mm<sup>2</sup></b>				
100105	3G2.5	8.3	13.0	7.2
100106	4G2.5	9.1	15.9	9.6
100107	5G2.5	10.2	19.8	12.0
<b>4 mm<sup>2</sup></b>				
100118	4G4	11.0	24.2	15.4
100119	5G4	12.3	30.1	19.2
<b>6 mm<sup>2</sup></b>				
100123	4G6	12.7	34.1	23.0
100124	5G6	14.3	42.3	28.8

CE These products are in conformity with the EU Low Voltage Directive 2006/95/EC

# PVC control cables - unshielded

## LÜTZE SILFLEX® N PVC



### Application

- Machine and device construction, transport and conveyor technology, HVAC technology
- In dry and damp rooms
- As a monitoring, measurement and control cable for industrial applications
- For flexible application without continuous flexing

### Properties

- PVC Flame-retardant, self-extinguishing
- Resistant to most oils, greases, acids and alkalis
- Silicone free
- RoHS-compliant

### Technical data

Voltage	
U <sub>0</sub> /U	300/500 V
Test voltage	3000 V
Insulation resistance	min. 20 MΩ × km
Temperature range	
moving	-15 °C to +70 °C
fixed	-40 °C to +80 °C
Minimum bending radius	
moving	D × 10
fixed	D × 4
Burning behavior	Flame-retardant according to VDE 0482 part 265-2, DIN EN 50265-2, IEC 60332-1

### Construction

- Bare copper wire, finely stranded according to DIN VDE 0295 class 5, IEC 60228 class 5
- Conductor insulation Special PVC TI2 according to VDE 0281-1
- Conductors black with white number print according to DIN EN 50334
- Ground conductor green/yellow according to DIN EN 50334 in the top layer  
G = with green/yellow ground conductor, × = without ground conductor
- Conductors cabled in layers
- Jacket special PVC TM2 according to VDE 0281-1, matte, adhesion-free surface
- Jacket color grey RAL 7001

Part-No.	Number of conductors/cross-section	Outer Ø ca. mm	Weight kg/100 m	Cu-Index kg/100 m
<b>0.5 mm<sup>2</sup></b>				
100363	2×0.5	5.0	3.5	1.0
100364	3G0.5	5.2	4.1	1.4
100365	4G0.5	5.6	5.0	1.9
108208	4×0.5	5.7	5.0	1.9
100366	5G0.5	6.3	6.2	2.4
100215	7G0.5	7.0	7.9	3.4
100369	10G0.5	8.5	11.3	4.8
100370	12G0.5	8.9	12.7	5.8
100373	18G0.5	10.9	19.0	8.6
100358	25G0.5	12.7	24.8	12.0
<b>0.75 mm<sup>2</sup></b>				
100384	2×0.75	5.6	4.3	1.4
100385	3G0.75	5.6	5.1	2.2
100386	4G0.75	6.3	6.5	2.9
100736	4×0.75	6.3	6.5	2.9
100387	5G0.75	6.9	8.0	3.6
100389	7G0.75	7.5	9.8	5.0
100391	10G0.75	9.2	14.3	7.2
100392	12G0.75	9.9	16.7	8.6
100395	18G0.75	11.7	23.8	13.0
100398	25G0.75	14.0	33.4	18.0
<b>1.0 mm<sup>2</sup></b>				
100405	2×1.0	5.9	5.0	1.9
100406	3G1.0	5.9	6.0	2.9
100407	4G1.0	6.7	7.7	3.8
100737	4×1.0	6.7	7.7	3.8
100408	5G1.0	7.3	9.4	4.8
100410	7G1.0	8.1	12.1	6.7
100411	8G1.0	8.8	13.7	7.7
100412	10G1.0	10.0	17.6	9.6
100413	12G1.0	10.5	20.0	11.5
100415	16G1.0	11.9	26.0	15.4
100416	18G1.0	12.8	29.7	17.3
100417	25G1.0	14.8	40.5	24.0
100419	34G1.0	17.2	54.6	32.6
<b>1.5 mm<sup>2</sup></b>				
100429	2×1.5	6.0	6.6	2.9
100430	3G1.5	6.8	8.1	4.3
100431	4G1.5	7.4	10.0	5.8
100432	5G1.5	8.3	12.5	7.2
100433	7G1.5	9.0	15.7	10.1
100437	12G1.5	11.7	26.4	17.3
100440	18G1.5	14.4	39.1	25.9
100443	25G1.5	16.9	54.4	36.0
<b>2.5 mm<sup>2</sup></b>				
118389	2×2.5	7.7	9.9	4.8
100453	3G2.5	8.3	12.6	7.2
100454	4G2.5	9.0	15.6	9.6
100455	5G2.5	10.1	19.6	12.0
100456	7G2.5	11.2	25.3	16.8
100458	12G2.5	14.6	42.3	28.8
<b>4 mm<sup>2</sup></b>				
100871	2×4	9.5	14.8	7.7
100990	3G4	9.8	18.8	11.5
100464	4G4	11.0	24.2	15.4
100465	5G4	12.1	29.5	19.2
<b>6 mm<sup>2</sup></b>				
100468	4G6	12.8	33.9	23.0
100469	5G6	14.3	42.3	28.8

CE These products are in conformity with the EU Low Voltage Directive 2006/95/EC

# PVC control cables - shielded

## LÜTZE SILFLEX® N (C) PVC



### Application

- Machine and device construction, transport and conveyor technology, HVAC technology
- In dry and damp rooms
- As a monitoring, measurement and control cable for industrial applications
- For flexible application without continuous flexing
- Anywhere where electrical interference fields can influence the signal transmission

### Properties

- The overall braided copper shield prevents both the interference of signals and measured values as well as the emission of interfering signals
- PVC Flame-retardant, self-extinguishing
- Resistant to most oils, greases, acids and alkalis
- Silicone free
- RoHS-compliant

### Technical data

Voltage	
U <sub>0</sub> /U	300/500 V
Test voltage	3000 V
Insulation resistance	min. 20 MΩ × km
Temperature range	
moving	-5 °C to +70 °C
fixed	-40 °C to +80 °C
Minimum bending radius	
moving	D × 15
fixed	D × 6
Burning behavior	Flame-retardant according to VDE 0482 part 265-2, DIN EN 50265-2, IEC 60332-1

### Construction

- Bare copper wire, finely stranded according to DIN VDE 0295 class 5, IEC 60228 class 5
- Conductor insulation Special PVC T12 according to VDE 0281-1
- Conductors black with white number print according to DIN EN 50334
- Ground conductor green/yellow according to DIN EN 50334 in the top layer  
G = with green/yellow ground conductor, × = without ground conductor
- Conductors cabled in layers
- Braid from tinned copper wire, optical coverage ≥ 85 %
- Jacket special PVC TM2 according to VDE 0281-1, matte, adhesion-free surface
- Jacket color grey RAL 7001

Part-No.	Number of conductors/cross-section	Outer Ø ca. mm	Weight kg/100 m	Cu-Index kg/100 m
<b>0.5 mm<sup>2</sup></b>				
116191	(2×0.5)	5.5	4.5	2.2
116139	(3G0.5)	5.8	5.2	2.7
116297	(4G0.5)	6.3	6.7	3.7
116238	(5G0.5)	6.9	7.9	4.2
116235	(7G0.5)	7.5	10.0	5.6
116151	(12G0.5)	9.7	16.0	9.0
116152	(18G0.5)	11.5	22.4	12.4
116250	(25G0.5)	13.4	30.8	17.8
<b>0.75 mm<sup>2</sup></b>				
116174	(2×0.75)	5.9	5.7	3.2
116100	(3G0.75)	6.3	6.8	3.9
116102	(4G0.75)	6.8	8.1	4.6
116103	(5G0.75)	7.5	10.1	5.9
116104	(7G0.75)	8.2	12.3	7.3
116105	(12G0.75)	10.7	19.8	11.9
116106	(18G0.75)	12.6	28.6	17.1
116107	(25G0.75)	14.8	39.4	24.6
<b>1.0 mm<sup>2</sup></b>				
116234	(2×1.0)	6.3	6.5	3.7
116110	(3G1.0)	6.7	7.7	4.6
116112	(4G1.0)	7.3	9.8	6.1
116113	(5G1.0)	8.0	11.7	7.1
116114	(7G1.0)	8.7	14.8	9.5
116115	(12G1.0)	11.4	23.8	15.2
116116	(18G1.0)	13.7	35.7	23.1
116117	(25G1.0)	15.8	46.6	30.6
<b>1.5 mm<sup>2</sup></b>				
116121	(3G1.5)	7.4	10.1	6.6
116123	(4G1.5)	8.1	12.4	8.0
116124	(5G1.5)	8.9	15.4	10.0
116125	(7G1.5)	9.8	19.5	13.3
116126	(12G1.5)	12.8	31.5	21.5
116127	(18G1.5)	15.4	47.5	32.5
116128	(25G1.5)	17.8	63.1	44.3
<b>2.5 mm<sup>2</sup></b>				
116132	(3G2.5)	8.9	14.8	10.0
116133	(4G2.5)	9.8	18.9	12.9
116134	(5G2.5)	10.8	22.8	15.3
116135	(7G2.5)	11.8	29.1	20.5
<b>4 mm<sup>2</sup></b>				
116150	(4G4)	11.5	27.4	19.1
<b>6 mm<sup>2</sup></b>				
116153	(4G6)	13.8	41.2	28.8

CE These products are in conformity with the EU Low Voltage Directive 2006/95/EC

# PVC control cables - unshielded

## LÜTZE SILFLEX® N PVC MULTINORM With approvals for Europe and North America



### Application

- Machine and device construction, transport and conveyor technology, HVAC technology
- In dry and damp rooms
- As a monitoring, measurement and control cable for industrial applications
- For flexible application without continuous flexing

### Properties

- Certified as component cable for use in North America
- Easy stripping and fast installation
- High flexibility for complex installation distances and small bending radii
- Improved oil resistance due to specifically developed PVC jacket
- Resistant to many oils, coolants and solvents
- Hydrolysis and microbe resistant
- Silicone free
- RoHS-compliant

### Technical data

UL approval	AWM 2587
Voltage	
according to UL	600 V 90 °C
according to VDE	300/500 V 70 °C
Test voltage	6000 V
Insulation resistance	min. 20 MΩ × km
Temperature range	
moving according to UL	-5 °C to +90 °C
fixed according to UL	-40 °C to +90 °C
moving according to VDE	-5 °C to +70 °C
fixed according to VDE	-25 °C to +70 °C
Minimum bending radius	
moving	D × 10
fixed	D × 4
Approvals	cULus AWM Style 2587 CSA AWM I/II A/B FT1 CE Oil Res II RoHS
Burning behavior	IEC 60332-1, IEC 60332-3-24, CSA FT1, UL-VW-1

### Construction

- Bare copper wire, finely stranded according to DIN VDE 0295 class 5, IEC 60228 class 5
- Conductor insulation Special PVC according to T12 and UL 1581
- Conductors black with white number print according to DIN EN 50334
- Ground conductor green/yellow according to DIN EN 50334 in the top layer
- G = with green/yellow ground conductor, × = without ground conductor
- Conductors cabled in layers
- Jacket special PVC according to VDE 0289 TM2 and UL 1581
- Jacket color grey RAL 7001

Part-No.	Number of conductors/cross-section	Outer Ø ca. mm	Weight kg/100 m	Cu-Index kg/100 m
<b>0.5 mm<sup>2</sup></b>				
109700	2×0.5	5.0	3.8	1.0
109701	3G0.5	5.3	4.6	1.4
109702	4G0.5	5.7	5.5	1.9
109703	5G0.5	6.3	6.8	2.4
109704	7G0.5	6.8	8.7	3.4
109705	12G0.5	8.7	14.8	5.8
109707	18G0.5	10.4	21.3	8.6
109708	25G0.5	12.1	29.4	12.0
<b>0.75 mm<sup>2</sup></b>				
109711	2×0.75	5.4	4.7	1.5
109712	3G0.75	5.7	5.7	2.2
109713	4G0.75	6.2	7.0	2.9
109714	5G0.75	6.8	8.9	3.6
109715	7G0.75	7.4	11.2	5.0
109716	12G0.75	9.5	19.5	8.6
109718	18G0.75	11.4	28.2	12.9
109719	25G0.75	13.3	39.1	18.0
<b>1.0 mm<sup>2</sup></b>				
109720	2×1.0	5.7	5.5	1.9
109721	3G1.0	6.1	6.9	2.9
109722	4G1.0	6.6	8.5	3.8
109723	5G1.0	7.2	10.6	4.8
109724	7G1.0	7.8	13.4	6.7
109725	12G1.0	10.3	23.5	11.5
109727	18G1.0	12.3	34.6	17.3
109728	25G1.0	14.3	47.0	24.0
109729	34G1.0	16.9	65.3	32.6
<b>1.5 mm<sup>2</sup></b>				
109730	2×1.5	6.3	7.2	2.9
109731	3G1.5	6.7	9.4	4.3
109732	4G1.5	7.3	11.6	5.8
109733	5G1.5	8.0	14.6	7.2
109734	7G1.5	8.7	18.5	10.1
109735	12G1.5	11.5	32.3	17.3
109737	18G1.5	13.8	47.6	25.9
109738	25G1.5	16.0	65.3	36.0
<b>2.5 mm<sup>2</sup></b>				
109740	3G2.5	8.0	14.6	7.2
109741	4G2.5	8.7	18.1	9.6
109742	5G2.5	9.6	22.7	12.0
109743	7G2.5	10.7	29.7	16.8
109744	12G2.5	14.4	51.5	28.8
<b>4 mm<sup>2</sup></b>				
109749	3G4	9.3	21.6	11.5
109750	4G4	10.5	27.4	15.4
109751	5G4	11.5	33.9	19.2
109752	7G4	12.8	44.5	26.9
<b>6 mm<sup>2</sup></b>				
109753	4G6	12.4	39.9	23.0
109754	5G6	13.7	49.8	28.8
<b>10 mm<sup>2</sup></b>				
109323	4×10	15.9	66.2	38.4
109859	5G10	17.9	83.8	48.0
<b>16 mm<sup>2</sup></b>				
109860	4G16	18.7	98.2	61.4
<b>25 mm<sup>2</sup></b>				
109861	4G25	23.8	155.9	96.0
<b>35 mm<sup>2</sup></b>				
109864	4G35	26.7	209.8	134.4
<b>50 mm<sup>2</sup></b>				
109865	4G50	32.6	299.9	192.0

CE These products are in conformity with the EU Low Voltage Directive 2006/95/EC

# PVC control cables - shielded

## LÜTZE SILFLEX® N (C) PVC MULTINORM With approvals for Europe and North America



### Application

- Machine and device construction, transport and conveyor technology, HVAC technology
- In dry and damp rooms
- As a monitoring, measurement and control cable for industrial applications
- For flexible application without continuous flexing
- Anywhere where electrical interference fields can influence the signal transmission

### Properties

- Certified as component cable for use in North America
- Easy stripping and fast installation
- High flexibility for complex installation distances and small bending radii
- Improved oil resistance due to specifically developed PVC jacket
- Resistant to many oils, coolants and solvents
- Hydrolysis and microbe resistant
- Silicone free
- RoHS-compliant

### Technical data

UL approval	AWM 2587
Voltage	
according to UL	600 V 90 °C
according to VDE	300/500 V 70 °C
Test voltage	4000 V
Insulation resistance	min. 20 MΩ × km
Temperature range	
moving according to UL	-5 °C to +90 °C
fixed according to UL	-40 °C to +90 °C
moving according to VDE	-5 °C to +70 °C
fixed according to VDE	-25 °C to +70 °C
Minimum bending radius	
moving	D × 15
fixed	D × 6
Burning behavior	IEC 60332-1, IEC 60332-3-24, CSA FT1
Approvals	cULus AWM Style 2587 UL-VW-1 CSA AWM I/II A/B FT1 CE Oil Res II RoHS

### Construction

- Bare copper wire, finely stranded according to DIN VDE 0295 class 5, IEC 60228 class 5
- Conductor insulation Special PVC according to TI2 and UL 1581
- Conductors black with white number print according to DIN EN 50334
- Ground conductor green/yellow according to DIN EN 50334 in the top layer  
G = with green/yellow ground conductor, × = without ground conductor
- Conductors cabled in layers
- Fleece wrap
- Braid from tinned copper wire, optical coverage ≥ 85 %
- Jacket special PVC according to VDE 0289 TM2 and UL 1581
- Jacket color grey RAL 7001

Part-No.	Number of conductors/cross-section	Outer Ø ca. mm	Weight kg/100 m	Cu-Index kg/100 m
<b>0.5 mm<sup>2</sup></b>				
109800	(2×0.5)	5.6	4.7	2.2
109801	(3G0.5)	5.9	5.4	2.7
109802	(4G0.5)	6.3	6.8	3.7
109803	(5G0.5)	6.9	8.2	4.2
109804	(7G0.5)	7.4	10.1	5.6
109805	(12G0.5)	9.3	16.4	8.9
109807	(18G0.5)	11.0	22.8	12.2
109808	(25G0.5)	12.7	31.0	16.1
<b>0.75 mm<sup>2</sup></b>				
109812	(3G0.75)	6.3	6.8	3.9
109813	(4G0.75)	6.8	8.4	4.6
109814	(5G0.75)	7.4	10.2	5.8
109815	(7G0.75)	8.0	12.6	7.3
109816	(12G0.75)	10.3	19.9	11.8
109818	(18G0.75)	12.2	29.1	17.0
109819	(25G0.75)	14.3	39.7	24.4
<b>1.0 mm<sup>2</sup></b>				
109821	(3G1.0)	6.7	8.0	4.6
109822	(4G1.0)	7.2	10.0	6.1
109823	(5G1.0)	7.8	11.7	7.1
109824	(7G1.0)	8.4	15.0	9.4
109825	(12G1.0)	10.9	24.2	15.1
109827	(18G1.0)	12.9	35.7	21.3
109828	(25G1.0)	15.1	47.1	30.4
<b>1.5 mm<sup>2</sup></b>				
109831	(3G1.5)	7.3	10.3	6.6
109832	(4G1.5)	7.9	12.9	6.0
109833	(5G1.5)	8.6	15.6	9.9
109834	(7G1.5)	9.5	20.0	13.2
109835	(12G1.5)	12.3	32.2	21.3
109837	(18G1.5)	14.8	48.5	32.3
109838	(25G1.5)	17.0	63.0	43.2
<b>2.5 mm<sup>2</sup></b>				
109840	(3G2.5)	8.6	15.1	9.9
109841	(4G2.5)	9.3	19.4	12.7
109842	(5G2.5)	10.4	23.0	15.1
109843	(7G2.5)	11.3	29.6	20.4
109844	(12G2.5)	15.2	50.8	35.2
<b>4 mm<sup>2</sup></b>				
109862	(4G4)	11.1	27.9	18.9
<b>6 mm<sup>2</sup></b>				
109863	(4G6)	13.2	40.5	28.6

CE These products are in conformity with the EU Low Voltage Directive 2006/95/EC

# PUR control cables - unshielded

## LÜTZE SILFLEX® N PUR



### Application

- Machine and device construction, transport and conveyor technology, HVAC technology
- In areas with high concentrations of people or material assets, where corrosive gases need to be avoided in the event of fire
- As a monitoring, measurement and control cable for industrial applications
- Especially for rough environments
- For flexible applications without continuous flexing

### Properties

- Low capacitance, very good electrical properties
- Flexible in cold environments
- Halogen-free, no corrosive gases
- Low adhesion, Abrasion-resistant, Tear resistant
- Hydrolysis-resistant, microbe-resistant, and rot-resistant
- Weatherproof, ozone and UV resistant (normal lighting conditions)
- Good ruggedness and salt water resistance
- Excellent coolant and lubricant resistance
- Resistant to most oils, greases, alcohol-free benzines and kerosene
- Silicone free
- RoHS-compliant

### Technical data

Voltage	
U <sub>0</sub> /U	300/500 V
Test voltage	3000 V
Insulation resistance	min. 100 MΩ × km
Temperature range	
moving	-25 °C to +80 °C
fixed	-40 °C to +80 °C
Minimum bending radius	
moving	D × 10
fixed	D × 4
Halogen free	according DIN EN 50267-2-1

### Construction

- Bare copper wire, finely stranded according to DIN VDE 0295 class 5, IEC 60228 class 5
- Conductor insulation Special-TPE based on VDE 0207
- Conductors black with white number print according to DIN EN 50334
- Ground conductor green/yellow according to DIN EN 50334 in the top layer
- G = with green/yellow ground conductor, × = without ground conductor
- Conductors cabled in layers
- Jacket special-PUR, matte, adhesion-free surface
- Jacket color grey RAL 7001

Part-No.	Number of conductors/cross-section	Outer Ø ca. mm	Weight kg/100 m	Cu-Index kg/100 m
<b>0.5 mm<sup>2</sup></b>				
110437	2×0.5	4.5	2.6	1.0
110196	3G0.5	4.7	3.2	1.5
110457	4G0.5	5.1	4.0	1.9
110372	5G0.5	5.9	5.2	2.4
111016	7G0.5	6.4	6.6	3.4
111707	12G0.5	8.7	11.8	5.8
110644	18G0.5	10.0	17.2	8.6
110459	25G0.5	12.1	23.6	12.0
<b>0.75 mm<sup>2</sup></b>				
110168	2×0.75	5.0	3.3	1.4
110197	3G0.75	5.3	4.2	2.2
110169	4G0.75	5.8	5.5	2.9
110991	5G0.75	6.4	6.7	3.6
110424	7G0.75	7.2	8.9	5.0
110506	12G0.75	9.5	15.4	8.6
110992	18G0.75	11.2	23.0	13.0
110526	25G0.75	13.5	31.6	18.0
<b>1.0 mm<sup>2</sup></b>				
110443	2×1.0	5.4	3.9	2.0
110182	3G1.0	5.8	5.3	2.9
110418	4G1.0	6.3	6.6	3.8
110184	5G1.0	6.8	8.1	4.8
110185	7G1.0	7.7	10.8	6.7
110188	12G1.0	10.3	19.0	11.5
110189	18G1.0	12.3	27.9	17.3
110191	25G1.0	14.5	38.7	24.0
<b>1.5 mm<sup>2</sup></b>				
110177	3G1.5	6.4	7.1	4.3
110186	4G1.5	7.1	9.3	5.8
110178	5G1.5	8.0	11.4	7.2
110179	7G1.5	8.7	15.1	10.1
110180	12G1.5	11.7	26.6	17.3
110181	18G1.5	14.0	39.0	25.9
110183	25G1.5	16.4	53.9	36.0
<b>2.5 mm<sup>2</sup></b>				
111102	3G2.5	7.8	11.4	7.2
110192	4G2.5	8.7	14.7	9.6
110193	5G2.5	9.6	18.1	12.0
110194	7G2.5	10.7	24.1	16.8
<b>4 mm<sup>2</sup></b>				
110195	4G4	11.0	22.4	15.4
<b>6 mm<sup>2</sup></b>				
110450	4G6	12.7	32.4	23.0

CE These products are in conformity with the EU Low Voltage Directive 2006/95/EC

# PUR control cables - shielded

## LÜTZE SILFLEX<sup>®</sup> N (C) PUR



### Application

- Machine and device construction, transport and conveyor technology, HVAC technology
- In areas with high concentrations of people or material assets, where corrosive gases need to be avoided in the event of fire
- As a monitoring, measurement and control cable for industrial applications
- Especially for rough environments
- For flexible applications without continuous flexing
- Anywhere where electrical interference fields can influence the signal transmission

### Properties

- The overall shield of braided copper wires prevents both the interference of signals and measured values as well as the radiation of interfering signals
- High active and passive interference resistance (EMC)
- Low capacitance, very good electrical properties
- Flexible in cold environments
- Halogen-free, no corrosive gases
- Low adhesion, abrasion-resistant, nick-resistant, tear resistant
- Hydrolysis-resistant, microbe-resistant, and rot-resistant
- Weatherproof, ozone and UV resistant (normal lighting conditions)
- Good ruggedness and salt water resistance
- Excellent coolant and lubricant resistance
- Resistant to most oils, greases, alcohol-free benzines and kerosene
- Silicone free
- RoHS-compliant

### Technical data

Voltage	
U <sub>0</sub> /U	300/500 V
Test voltage	3000 V
Insulation resistance	min. 100 MΩ × km
Temperature range	
moving	-25 °C to +80 °C
fixed	-40 °C to +80 °C
Minimum bending radius	
moving	D × 15
fixed	D × 6
Halogen free	according DIN EN 50267-2-1

### Construction

- Bare copper wire, finely stranded according to DIN VDE 0295 class 5, IEC 60228 class 5
- Conductor insulation Special-TPE based on VDE 0207
- Conductors black with white number print according to DIN EN 50334
- Ground conductor green/yellow according to DIN EN 50334 in the top layer
- G = with green/yellow ground conductor, × = without ground conductor
- Conductors cabled in layers
- Braid from tinned copper wire, optical coverage ≥ 85 %
- Jacket special-PUR, matte, adhesion-free surface
- Jacket color grey RAL 7001

Part-No.	Number of conductors/cross-section	Outer Ø ca. mm	Weight kg/100 m	Cu-Index kg/100 m
<b>0.5 mm<sup>2</sup></b>				
111651	(2×0.5)	5.2	3.8	2.3
111652	(3G0.5)	5.5	4.5	2.8
111653	(4G0.5)	5.9	6.0	3.7
111654	(5G0.5)	6.5	7.0	4.8
111656	(7G0.5)	7.2	9.1	5.6
111657	(12G0.5)	9.3	14.6	9.0
111658	(18G0.5)	10.8	20.6	12.4
111659	(25G0.5)	12.7	28.9	17.8
<b>0.75 mm<sup>2</sup></b>				
111660	(2×0.75)	5.6	4.7	2.8
111661	(3G0.75)	6.0	6.0	3.9
111662	(4G0.75)	6.5	7.2	4.6
111663	(5G0.75)	7.2	9.2	5.8
111664	(7G0.75)	7.8	11.8	7.4
111665	(12G0.75)	10.1	18.4	11.9
111666	(18G0.75)	12.0	26.6	17.2
111667	(25G0.75)	14.2	37.2	24.6
<b>1.0 mm<sup>2</sup></b>				
111668	(2×1.0)	6.0	5.7	3.7
111669	(3G1.0)	6.3	6.9	4.6
111670	(4G1.0)	6.8	8.8	6.1
111671	(5G1.0)	7.6	10.6	7.1
111672	(7G1.0)	8.2	13.5	9.5
111673	(12G1.0)	10.9	22.0	15.3
111674	(18G1.0)	12.7	33.5	23.1
111675	(25G1.0)	15.3	43.7	30.6
<b>1.5 mm<sup>2</sup></b>				
111676	(2×1.5)	6.6	7.0	4.7
111677	(3G1.5)	7.0	9.4	6.6
111678	(4G1.5)	7.6	11.4	8.1
111679	(5G1.5)	8.6	14.4	10.0
111680	(7G1.5)	9.3	18.2	13.4
111681	(12G1.5)	12.3	29.6	21.5
111682	(18G1.5)	14.4	45.2	32.6
<b>2.5 mm<sup>2</sup></b>				
111684	(3G2.5)	8.6	13.9	10.1
111685	(4G2.5)	9.3	17.6	12.9
111686	(5G2.5)	10.4	21.4	15.3
111687	(7G2.5)	11.2	27.8	20.5
<b>4 mm<sup>2</sup></b>				
111688	(4G4)	11.8	25.7	19.1
<b>6 mm<sup>2</sup></b>				
111690	(4G6)	13.4	38.3	28.9

CE These products are in conformity with the EU Low Voltage Directive 2006/95/EC

# LÜTZE SUPERFLEX® and LÜTZE SUPERFLEX® PLUS



## LÜTZE SUPERFLEX®

← *connected*

**LÜTZE SUPERFLEX® sets Industry Standards:  
longevity, reliability, flexibility**

LÜTZE SUPERFLEX® flexing cables are specifically designed for use in continuous motion applications such as drag chains.

Find here more informations  
about LÜTZE SUPERFLEX®  
<http://bit.ly/ZUdgUK>





# PVC control cables - C-track compatible - unshielded

## LÜTZE SUPERFLEX® N PVC For medium to high requirements

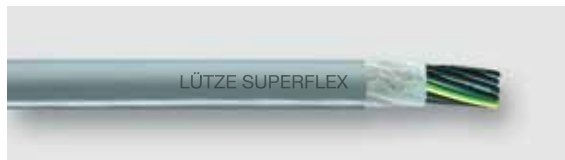

### Application

- Machine and device construction, transport and conveyor technology, HVAC technology
- In dry and damp rooms
- As a monitoring, measurement and control cable in continuously moving applications
- For installation in energy chains with constant linear movement

### Properties

- Construction and material suitable for continuous movement application.
- PVC Flame-retardant, self-extinguishing
- Resistant to most oils, greases, acids and alkalis (see tech. information)
- Silicone free
- RoHS-compliant

### Technical data

#### Voltage

U<sub>0</sub>/U 300/500 V

Test voltage 3000 V

Insulation resistance min. 20 MΩ × km

#### Temperature range

moving -15 °C to +80 °C  
fixed -30 °C to +80 °C

#### Minimum bending radius

moving D × 10  
fixed D × 4

#### Radiation-resistance

8 × 10<sup>7</sup> cJ/kg

#### Burning behavior

Flame-retardant according to  
VDE 0482 part 265-2-2  
DIN EN 50265-2-2  
IEC 60332-2-2

### Construction

- Bare copper wire, super finely stranded according to DIN VDE 0295 class 6, IEC 60228 class 6
- Conductor insulation Special PVC T12 according to VDE 0281-1
- Conductors black with white number print according to DIN EN 50334
- Ground conductor green/yellow according to DIN EN 50334 in the top layer  
G = with green/yellow ground conductor, × = without ground conductor
- Conductors cabled in layers without mechanical stress, layer pitch optimised
- Fleece wrap over cable core
- Jacket special-PVC TM2 and TM4 according to VDE 0281
- Jacket color grey RAL 7001

Part-No.	Number of conductors/cross-section	Outer Ø ca. mm	Weight kg/100 m	Cu-Index kg/100 m
<b>0.5 mm<sup>2</sup></b>				
101049	3G0.5	5.0	3.8	1.5
118383	4G0.5	5.4	4.7	2.0
118393	5G0.5	5.9	5.6	2.5
118384	7G0.5	6.8	7.3	3.4
101351	12G0.5	8.1	11.1	5.9
101048	18G0.5	9.4	15.6	8.8
108055	25G0.5	11.1	21.3	12.3
<b>0.75 mm<sup>2</sup></b>				
100765	2×0.75	5.4	4.4	1.5
100766	3G0.75	5.5	5.0	2.2
111045	4G0.75	6.0	6.1	2.9
100767	5G0.75	6.5	7.3	3.7
100768	7G0.75	7.5	10.0	5.1
100998	12G0.75	9.1	14.9	8.8
100778	18G0.75	10.6	21.3	13.2
100856	25G0.75	12.6	29.0	18.3
<b>1.0 mm<sup>2</sup></b>				
100788	2×1.0	5.7	5.2	2.0
100789	3G1.0	6.0	6.4	3.0
100761	4G1.0	6.5	7.6	4.0
100777	5G1.0	7.0	9.0	5.0
100790	7G1.0	8.2	12.7	6.9
100791	12G1.0	9.8	18.5	11.9
100782	18G1.0	11.5	27.1	17.8
100784	25G1.0	13.7	36.8	24.8
<b>1.5 mm<sup>2</sup></b>				
101424	2×1.5	6.3	6.5	2.9
100796	3G1.5	6.6	8.2	4.4
100787	4G1.5	7.2	10.1	5.9
100808	5G1.5	7.8	12.3	7.4
100792	7G1.5	9.2	17.0	10.3
100793	12G1.5	11.2	25.6	17.6
100794	18G1.5	13.0	36.8	26.5
100795	25G1.5	15.6	51.4	36.8
<b>2.5 mm<sup>2</sup></b>				
100987	2×2.5	8.0	10.8	4.8
100893	3G2.5	8.3	13.3	7.3
100707	4G2.5	9.1	16.5	9.7
100769	5G2.5	9.9	19.9	12.2
100797	7G2.5	11.8	28.1	17.0
100807	12G2.5	14.3	42.2	29.2
100900	18G2.5	16.8	62.4	43.8
<b>4 mm<sup>2</sup></b>				
108049	4G4	11.8	30.0	15.4

CE These products are in conformity with the EU Low Voltage Directive 2006/95/EC

# PVC control cables - C-track compatible - shielded

## LÜTZE SUPERFLEX® N (C) PVC For medium to high requirements



### Application

- Machine and device construction, transport and conveyor technology, HVAC technology
- In dry and damp rooms
- As a monitoring, measurement and control cable in continuously moving applications
- For installation in energy chains with constant linear movement
- Anywhere where electrical interference fields can influence the signal transmission

### Properties

- Construction and material suitable for continuous movement application.
- High active and passive interference resistance
- PVC Flame-retardant, self-extinguishing
- Resistant to most oils, greases, acids and alkalis (see tech. information)
- Silicone free
- RoHS-compliant

### Technical data

Voltage	
U <sub>0</sub> /U	300/500 V
Test voltage	3000 V
Insulation resistance	min. 20 MΩ × km
Temperature range	
moving	-15 °C to +80 °C
fixed	-30 °C to +80 °C
Minimum bending radius	
moving	D × 12
fixed	D × 6
Radiation-resistance	8 × 10 <sup>7</sup> cJ/kg
Burning behavior	Flame-retardant according to VDE 0482 part 265-2-2 DIN EN 50265-2-2 IEC 60332-2-2

### Construction

- Bare copper wire, super finely stranded according to DIN VDE 0295 class 6, IEC 60228 class 6
- Conductor insulation Special PVC TI2 according to VDE 0281-1
- Conductors black with white number print according to DIN EN 50334
- Ground conductor green/yellow according to DIN EN 50334 in the top layer  
G = with green/yellow ground conductor, × = without ground conductor
- Conductors cabled in layers without mechanical stress, layer pitch optimised
- Sub jacket PVC
- Braid from tinned copper wire, optical coverage ≥ 85 %
- Fleece wrap over cable core
- Jacket special-PVC TM2 and TM4 according to VDE 0281
- Jacket color grey RAL 7001

Part-No.	Number of conductors/cross-section	Outer Ø ca. mm	Weight kg/100 m	Cu-Index kg/100 m
<b>0.5 mm<sup>2</sup></b>				
110446	(2×0.5)	6.6	7.1	2.2
101288	(3G0.5)	6.8	6.8	2.8
108800	(4G0.5)	7.0	7.4	3.4
118039	(5G0.5)	7.6	9.1	4.0
108801	(7G0.5)	8.5	11.0	5.5
108802	(12G0.5)	10.0	15.0	8.0
<b>0.75 mm<sup>2</sup></b>				
110489	(2×0.75)	7.1	7.5	2.8
108803	(3G0.75)	7.2	8.2	3.6
108000	(4G0.75)	7.0	7.4	3.4
111245	(5G0.75)	8.3	11.4	5.4
108001	(7G0.75)	8.6	13.1	7.0
110563	(12G0.75)	8.6	13.1	7.0
108002	(18G0.75)	12.1	27.2	16.9
110564	(25G0.75)	14.0	35.6	22.7
<b>1.0 mm<sup>2</sup></b>				
111246	(2×1.0)	7.3	8.3	3.5
111215	(3G1.0)	7.6	9.4	4.5
110567	(4G1.0)	8.1	11.0	5.7
118042	(5G1.0)	8.6	12.6	6.8
118239	(7G1.0)	9.2	15.4	8.9
111001	(12G1.0)	11.5	24.1	15.4
111247	(18G1.0)	13.0	32.6	21.9
111248	(25G1.0)	15.3	43.8	30.4
<b>1.5 mm<sup>2</sup></b>				
110947	(2×1.5)	8.0	10.3	4.8
110954	(3G1.5)	8.4	11.9	6.6
110499	(4G1.5)	9.0	14.4	8.0
118194	(5G1.5)	10.4	18.8	10.5
111303	(7G1.5)	11.2	23.2	13.7
111304	(12G1.5)	14.0	35.5	22.1
111305	(18G1.5)	16.0	49.4	32.5
111306	(25G1.5)	19.3	68.1	46.5
<b>2.5 mm<sup>2</sup></b>				
110608	(3G2.5)	10.0	18.6	10.3
108003	(4G2.5)	10.9	22.3	13.0
110701	(5G2.5)	11.0	25.9	15.8
111329	(7G2.5)	13.0	32.6	21.0

CE These products are in conformity with the EU Low Voltage Directive 2006/95/EC

# PVC control cables - C-track compatible - unshielded

## LÜTZE SUPERFLEX® N PVC For high requirements



### Application

- Machine and device construction, transport and conveyor technology, HVAC technology
- In dry and damp rooms
- As a monitoring, measurement and control cable for industrial applications
- For installation in energy chains with constant linear movement

### Properties

- Very small cable diameters due to special TPE conductor insulation (HGI) according to UL standard
- Reduced friction due to high glide conductor insulation (HGI) for high mechanical loads
- Flexibility due to super finely stranded wire construction
- Low capacitance, very good electrical properties
- Especially developed PVC jacket according to UL class 43
- Filler without wicking
- Low adhesion, abrasion-resistant, nick-resistant, tear resistant
- Hydrolysis-resistant, microbe-resistant, and rot-resistant
- Use in dry or damp environment
- Silicone free
- RoHS-compliant

### Technical data

UL approval	AWM 20207
Nominal voltage	600 V 80 °C
Test voltage	3000 V
Insulation resistance	min. 100 MΩ × km
Temperature range	
moving	-5 °C to +80 °C
fixed	-40 °C to +80 °C
Minimum bending radius	
moving	D × 7.5
fixed	D × 4
Burning behavior	Flame-retardant according to UL VW-1; DIN EN 50265-2-1
Approvals	cURus AWM Style 20207 IEC 60332-1, FT1

### Construction

- Bare copper wire, super finely stranded according to DIN VDE 0295 class 6, IEC 60228 class 6
- Conductor insulation Special TPE, high glide
- Conductors black with white number print according to DIN EN 50334
- Ground conductor green/yellow according to DIN EN 50334 in the top layer  
G = with green/yellow ground conductor, × = without ground conductor
- Conductors cabled in layers without mechanical stress, pitch layer optimised
- Fleece wrap over cable core
- Jacket special PVC according VDE 0207 TM5 and UL class 43
- Jacket color grey RAL 7001

Part-No.	Number of conductors/cross-section	Outer Ø ca. mm	Weight kg/100 m	Cu-Index kg/100 m
<b>0.5 mm<sup>2</sup></b>				
A1382003	3G0.5	5.7	4.5	1.5
A1382004	4G0.5	6.3	5.5	2.0
A1382005	5G0.5	6.8	6.4	2.5
A1382007	7G0.5	7.9	8.3	3.4
A1382012	12G0.5	9.5	12.3	5.9
A1382018	18G0.5	11.1	17.5	8.8
A1382025	25G0.5	13.2	23.8	12.3
<b>1.0 mm<sup>2</sup></b>				
A1381803	3G1.0	6.6	6.6	2.9
A1381804	4G1.0	7.2	8.1	4.0
A1381805	5G1.0	7.8	9.5	5.0
A1381807	7G1.0	9.2	13.5	6.9
A1381812	12G1.0	11.1	19.5	11.9
A1381818	18G1.0	13.0	27.9	17.8
A1381825	25G1.0	15.5	38.4	24.7
A1381834	34G1.0	17.8	50.4	33.7
A1381841	41G1.0	19.0	59.3	41.2
<b>1.5 mm<sup>2</sup></b>				
A1381603	3G1.5	7.2	8.7	4.4
A1381604	4G1.5	7.9	10.6	5.9
A1381605	5G1.5	8.7	12.8	7.4
A1381607	7G1.5	10.2	18.0	10.3
A1381612	12G1.5	12.4	26.7	17.6
A1381618	18G1.5	14.5	37.9	26.5
A1381625	25G1.5	17.4	52.1	34.4
<b>2.5 mm<sup>2</sup></b>				
A1381404	4G2.5	9.1	16.0	9.8
A1381405	5G2.5	10.1	26.8	12.2
A1381407	7G2.5	12.0	25.3	17.0
<b>4 mm<sup>2</sup></b>				
A1381204	4G4	10.8	23.2	15.6
A1381207	7G4	14.0	39.8	27.3

CE These products are in conformity with the EU Low Voltage Directive 2006/95/EC

# PVC control cables - C-track compatible - shielded

## LÜTZE SUPERFLEX® N (C) PVC For high requirements



### Application

- Machine and device construction, transport and conveyor technology, HVAC technology
- In dry and damp rooms
- As a monitoring, measurement and control cable for industrial applications
- For installation in energy chains with constant linear movement
- Anywhere where electrical interference fields can influence the signal transmission

### Properties

- Very small cable diameters due to special TPE conductor insulation (HGI) according to UL standard
- Reduced friction due to high glide conductor insulation (HGI) for high mechanical loads
- Low capacitance, very good electrical properties
- Especially developed PVC jacket according to UL class 43
- Filler without wick effect
- Low adhesion, abrasion-resistant, nick-resistant, tear resistant
- Hydrolysis-resistant, microbe-resistant, and rot-resistant
- Use in dry or damp environment
- Silicone free
- RoHS-compliant

### Technical data

UL approval	AWM 2570
Nominal voltage	600 V 80 °C
Test voltage	3000 V
Insulation resistance	min. 100 MΩ × km
Temperature range	
moving	-5 °C to +80 °C
fixed	-40 °C to +80 °C
Minimum bending radius	
moving	D × 10
fixed	D × 6
Burning behavior	Flame-retardant according to UL Cable Flame, DIN EN 50265-2-1, FT1
Approvals	cURus AWM Style 2570 IEC 60332-1, FT1

### Construction

- Bare copper wire, super finely stranded according to DIN VDE 0295 class 6, IEC 60228 class 6
- Conductor insulation Special TPE, high glide
- Conductors black with white number print according to DIN EN 50334
- Ground conductor green/yellow according to DIN EN 50334 in the top layer  
G = with green/yellow ground conductor, × = without ground conductor
- Conductors cabled in layers without mechanical stress, pitch layer optimised
- Fleece wrap over cable core
- Sub jacket PVC
- Braid from tinned copper wire, optical coverage ≥ 85 %
- Jacket special PVC according VDE 0207 TM5 and UL class 43
- Jacket color grey RAL 7001

Part-No.	Number of conductors/cross-section	Outer Ø ca. mm	Weight kg/100 m	Cu-Index kg/100 m
<b>0.5 mm<sup>2</sup></b>				
A1392003	(3G0.5)	7.4	7.7	3.1
A1392004	(4G0.5)	7.8	8.7	3.7
A1392005	(5G0.5)	8.5	10.2	4.4
A1392007	(7G0.5)	9.7	13.5	6.4
A1392012	(12G0.5)	11.3	18.5	9.6
A1392018	(18G0.5)	13.1	25.2	13.9
A1392025	(25G0.5)	15.1	30.1	17.8
<b>1.0 mm<sup>2</sup></b>				
A1391803	(3G1.0)	8.2	10.3	4.8
A1391804	(4G1.0)	8.8	14.7	6.0
A1391805	(5G1.0)	9.6	14.7	8.0
A1391807	(7G1.0)	11.0	18.9	10.5
A1391812	(12G1.0)	13.0	26.8	16.4
A1391818	(18G1.0)	14.9	36.8	24.0
A1391825	(25G1.0)	16.2	47.4	33.5
<b>1.5 mm<sup>2</sup></b>				
A1391603	(3G1.5)	8.8	12.6	6.5
A1391604	(4G1.5)	9.6	15.5	8.9
A1391605	(5G1.5)	10.4	18.2	10.7
A1391607	(7G1.5)	11.9	23.5	14.2
A1391612	(12G1.5)	14.1	34.7	22.5
A1391618	(18G1.5)	16.2	47.4	33.5
A1391625	(25G1.5)	19.4	64.3	46.5
<b>2.5 mm<sup>2</sup></b>				
A1391404	(4G2.5)	11.0	21.7	13.4
A1391405	(5G2.5)	11.9	25.4	16.2
A1391407	(7G2.5)	13.6	32.2	21.3
<b>4 mm<sup>2</sup></b>				
A1391204	(4G4)	12.6	30.2	20.1
A1391207	(7G4)	15.9	33.2	33.2

CE These products are in conformity with the EU Low Voltage Directive 2006/95/EC

# PUR control cables - C-track compatible - unshielded

## LÜTZE SUPERFLEX® PLUS N PUR 300 V For highest requirements



### Application

- Machine and device construction, transport and conveyor technology, HVAC technology
- In areas with high concentrations of people or material assets, where corrosive gases need to be avoided in the event of fire
- As a monitoring, measurement and control cable for industrial applications
- Especially for rough environments
- For installation in energy chains with constant linear movement

### Properties

- Reduced friction due to high glide conductor insulation (HGI) for high mechanical loads
- Low capacitance, very good electrical properties
- Flame-retardant, self-extinguishing
- Halogen-free, no corrosive gases
- Very good flexing strength
- Low adhesion, abrasion-resistant, nick-resistant, tear resistant
- Hydrolysis-resistant, microbe-resistant, and rot-resistant
- Weatherproof, ozone and UV resistant (normal lighting conditions)
- Good ruggedness and salt water resistance
- Excellent coolant and lubricant resistance
- Resistant to most oils, greases, alcohol-free benzines and kerosene
- Silicone free
- RoHS-compliant

### Technical data

UL approval	AWM 20233
Nominal voltage	300 V 80 °C
Voltage	
U <sub>0</sub> /U	300/500 V
Test voltage	3000 V
Insulation resistance	min. 1000 MΩ × km
Temperature range	
moving	-25 °C to +80 °C
fixed	-40 °C to +80 °C
Minimum bending radius	
moving	D × 7.5
fixed	D × 4
Radiation-resistance	5×10 <sup>8</sup> cJ/kg
Burning behavior	Flame-retardant according to VDE 0482 part 265-2; DIN EN 50265-2, IEC 60332-1, UL 1581 section Cable Flame-Test, CSA FT 1
Halogen free	according to EN 50267-2-1

### Construction

- Bare copper wire, super finely stranded according to DIN VDE 0295 class 6, IEC 60228 class 6
- Conductor insulation Special TPE, high glide
- Conductors black with white number print according to DIN EN 50334
- Ground conductor green/yellow according to DIN EN 50334 in the top layer  
G = with green/yellow ground conductor, × = without ground conductor
- Conductors cabled in layers without mechanical stress, layer pitch optimised
- Fleece wrap over cable core
- Jacket full PUR
- Jacket color grey RAL 7001

Part-No.	Number of conductors/cross-section	Outer Ø ca. mm	Weight kg/100 m	Cu-Index kg/100 m
<b>0.5 mm<sup>2</sup></b>				
113431	2×0.5	4.8	2.9	1.0
113441	3G0.5	5.0	3.4	1.5
113442	4G0.5	5.4	4.1	2.0
113443	5G0.5	5.8	4.8	2.5
113444	7G0.5	6.7	6.6	3.4
113446	12G0.5	8.0	9.7	5.9
113438	18G0.5	9.3	13.8	8.8
113447	25G0.5	11.0	18.9	12.3
<b>0.75 mm<sup>2</sup></b>				
113432	2×0.75	5.2	3.7	1.5
113445	3G0.75	5.5	4.4	2.2
113439	3×0.75	5.5	4.4	2.2
113435	4G0.75	5.9	5.4	2.9
113422	5G0.75	6.5	6.6	3.3
113437	7G0.75	7.5	8.8	5.1
113425	12G0.75	9.0	13.4	8.8
113428	18G0.75	10.5	19.0	13.2
113448	25G0.75	12.4	26.0	18.3
<b>1.0 mm<sup>2</sup></b>				
113484	2×1.0	5.6	4.2	2.0
113400	3G1.0	5.9	5.4	3.0
113433	4G1.0	6.4	6.8	4.0
113401	5G1.0	7.0	8.1	5.0
113402	7G1.0	8.2	11.2	6.9
113403	12G1.0	9.8	16.9	11.9
113404	18G1.0	11.4	24.4	17.8
113405	25G1.0	13.6	33.4	24.8

CE These products are in conformity with the EC Low Voltage Directive 73/23/EWG or 93/68/EWG respectively

# PUR control cables - C-track compatible - unshielded

## LÜTZE SUPERFLEX® PLUS N PUR 600 V For highest requirements



### Application

- Machine and device construction, transport and conveyor technology, HVAC technology
- In areas with high concentrations of people or material assets, where corrosive gases need to be avoided in the event of fire
- As a monitoring, measurement and control cable for industrial applications
- Especially for rough environments
- For installation in energy chains with constant linear movement

### Properties

- Reduced friction due to high glide conductor insulation (HGI) for high mechanical loads
- Low capacitance, very good electrical properties
- Flame-retardant, self-extinguishing
- Halogen-free, no corrosive gases
- Very good flexing strength
- Low adhesion, abrasion-resistant, nick-resistant, tear resistant
- Hydrolysis-resistant, microbe-resistant, and rot-resistant
- Weatherproof, ozone and UV resistant (normal lighting conditions)
- Good ruggedness and salt water resistance
- Excellent coolant and lubricant resistance
- Resistant to most oils, greases, alcohol-free benzines and kerosene
- Silicone free
- RoHS-compliant

### Technical data

UL approval	AWM 20234
Nominal voltage	600 V 80 °C
Voltage	
U <sub>0</sub> /U	300/500 V
Test voltage	6000 V
Insulation resistance	min. 1000 MΩ × km
Temperature range	
moving	-25 °C to +80 °C
fixed	-40 °C to +80 °C
Minimum bending radius	
moving	D × 7.5
fixed	D × 4
Radiation-resistance	5 × 10 <sup>8</sup> cJ/kg
Burning behavior	Flame-retardant according to VDE 0482 part 265-2; DIN EN 50265-2, IEC 60332-1, UL 1581 section Cable Flame-Test, CSA FT 1
Halogen free	according to EN 50267-2-1

### Construction

- Bare copper wire, super finely stranded according to DIN VDE 0295 class 6, IEC 60228 class 6
- Conductor insulation Special TPE, high glide
- Conductors black with white number print according to DIN EN 50334
- Ground conductor green/yellow according to DIN EN 50334 in the top layer
- G = with green/yellow ground conductor, × = without ground conductor
- Conductors cabled in layers without mechanical stress, layer pitch optimised
- Fleece wrap over cable core
- Jacket full PUR
- Jacket color grey RAL 7001

Part-No.	Number of conductors/cross-section	Outer Ø ca. mm	Weight kg/100 m	Cu-Index kg/100 m
<b>1.0 mm<sup>2</sup></b>				
113570	2×1.0	7.1	6.1	2.0
113571	3G1.0	7.4	7.3	3.0
113572	4G1.0	8.0	8.7	4.0
113573	5G1.0	8.7	10.5	5.0
113574	7G1.0	10.0	13.9	6.9
113575	12G1.0	12.0	20.5	11.9
113576	18G1.0	13.8	28.9	17.9
113577	25G1.0	16.4	39.3	24.8
<b>1.5 mm<sup>2</sup></b>				
113485	2×1.5	7.7	7.6	2.9
113406	3G1.5	8.0	9.2	4.4
113412	4G1.5	8.8	11.3	5.9
113407	5G1.5	9.5	13.6	7.4
113408	7G1.5	11.0	18.4	10.3
113409	12G1.5	13.2	27.2	17.6
113410	18G1.5	15.3	38.9	26.5
113411	25G1.5	18.2	54.0	36.8
<b>2.5 mm<sup>2</sup></b>				
113483	3G2.5	9.2	13.3	7.3
113415	4G2.5	10.0	16.3	9.7
113416	5G2.5	10.9	19.7	12.2
113417	7G2.5	12.8	27.3	17.0
113426	12G2.5	15.3	40.7	29.2
113479	18G2.5	17.8	58.9	43.8

# PUR control cables - C-track compatible - shielded

## LÜTZE SUPERFLEX® PLUS N (C) PUR 300 V For highest requirements



### Application

- Machine and device construction, transport and conveyor technology, HVAC technology
- In areas with high concentrations of people or material assets, where corrosive gases need to be avoided in the event of fire
- As a monitoring, measurement and control cable for industrial applications
- Especially for rough environments
- For installation in energy chains with constant linear movement
- Anywhere where electrical interference fields can influence the signal transmission

### Properties

- Reduced friction due to high glide conductor insulation (HGI) for high mechanical loads
- High active and passive interference resistance (EMC)
- Braided shield optimised for continuous flexing applications
- Low capacitance, very good electrical properties
- Flame-retardant, self-extinguishing
- Halogen-free, no corrosive gases
- Very good alternating bending strength
- Low adhesion, abrasion-resistant, nick-resistant, tear resistant
- Hydrolysis-resistant, microbe-resistant, and rot-resistant
- Weatherproof, ozone and UV resistant (normal lighting conditions)
- Good ruggedness and salt water resistance
- Excellent coolant and lubricant resistance
- Resistant to most oils, greases, alcohol-free benzines and kerosene
- Silicone free
- RoHS-compliant

### Technical data

UL approval	AWM 20233
Nominal voltage	300 V 80 °C
Voltage	
U <sub>0</sub> /U	300/500 V
Test voltage	3000 V
Insulation resistance	min. 1000 MΩ × km
Temperature range	
moving	-25 °C to +80 °C
fixed	-40 °C to +80 °C
Minimum bending radius	
moving	D × 10
fixed	D × 6
Radiation-resistance	5×10 <sup>8</sup> cJ/kg
Burning behavior	Flame retardant according to VDE 0482 Teil 265-2; DIN EN 50265-2; IEC 60332-1, UL 1581 section VW-1 Cable Flame-Test, CSA FT 1
Halogen free	according to EN 50267-2-1

### Construction

- Bare copper wire, super finely stranded according to DIN VDE 0295 class 6, IEC 60228 class 6
- Conductor insulation Special TPE, high glide
- Conductors black with white number print according to DIN EN 50334
- Ground conductor green/yellow according to DIN EN 50334 in the top layer  
G = with green/yellow ground conductor, × = without ground conductor
- Conductors cabled in layers without mechanical stress, layer pitch optimised
- Fleece wrap over cable core
- Sub jacket TPE
- Braid from tinned copper wire, optical coverage ≥ 85 %
- Jacket full PUR
- Jacket color grey RAL 7001

Part-No.	Number of conductors/cross-section	Outer Ø ca. mm	Weight kg/100 m	Cu-Index kg/100 m
<b>0.5 mm<sup>2</sup></b>				
113300	(3G0.5)	6.6	5.6	2.7
113347	(4G0.5)	7.0	6.4	3.3
113301	(5G0.5)	7.5	7.3	3.9
113302	(7G0.5)	8.3	9.1	5.1
113303	(12G0.5)	9.7	12.8	7.9
113304	(18G0.5)	11.0	17.9	11.9
113305	(25G0.5)	12.0	23.4	15.9
<b>0.75 mm<sup>2</sup></b>				
113328	(2×0.75)	6.9	6.3	2.8
113306	(3G0.75)	7.5	7.2	3.6
113430	(3×0.75)	7.5	7.2	3.6
113325	(4G0.75)	7.8	8.4	4.5
113345	(4×0.75)	7.8	8.4	4.5
113307	(5G0.75)	8.3	9.7	5.3
113308	(7G0.75)	9.4	12.4	7.1
113309	(12G0.75)	11.3	18.8	12.0
113310	(18G0.75)	13.0	25.4	16.9
113311	(25G0.75)	14.9	33.4	22.8
<b>1.0 mm<sup>2</sup></b>				
113312	(3G1.0)	7.8	8.4	4.5
113324	(4G1.0)	8.3	9.9	5.6
113313	(5G1.0)	9.1	11.4	6.8
113314	(7G1.0)	10.2	14.7	9.1
113315	(12G1.0)	12.1	22.5	15.4
113316	(18G1.0)	14.0	30.6	22.0
113317	(25G1.0)	15.8	41.5	30.5

# PUR control cables - C-track compatible - shielded

## LÜTZE SUPERFLEX® PLUS N (C) PUR 600 V For highest requirements

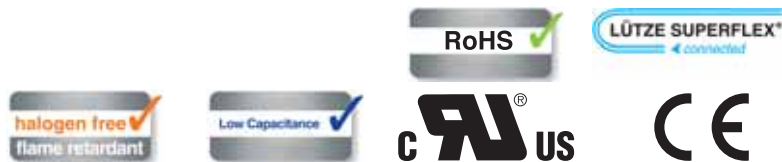

### Application

- Machine and device construction, transport and conveyor technology, HVAC technology
- In areas with high concentrations of people or material assets, where corrosive gases need to be avoided in the event of fire
- As a monitoring, measurement and control cable for industrial applications
- Especially for rough environments
- For installation in energy chains with constant linear movement
- Anywhere where electrical interference fields can influence the signal transmission

### Properties

- Reduced friction due to high glide conductor insulation (HGI) for high mechanical loads
- High active and passive interference resistance (EMC)
- Braided shield optimised for continuous flexing applications
- Low capacitance, very good electrical properties
- Flame-retardant, self-extinguishing
- Halogen-free, no corrosive gases
- Very good alternating bending strength
- Low adhesion, abrasion-resistant, nick-resistant, tear resistant
- Hydrolysis-resistant, microbe-resistant, and rot-resistant
- Weatherproof, ozone and UV resistant (normal lighting conditions)
- Good ruggedness and salt water resistance
- Excellent coolant and lubricant resistance
- Resistant to most oils, greases, alcohol-free benzines and kerosene
- Silicone free
- RoHS-compliant

### Technical data

UL approval	AWM 20234
Nominal voltage	600 V 80 °C
Voltage	
$U_0/U$	300/500 V
Test voltage	6000 V
Insulation resistance	min. 1000 M $\Omega$ × km
Temperature range	
moving	-25 °C to +80 °C
fixed	-40 °C to +80 °C
Minimum bending radius	
moving	D × 10
fixed	D × 6
Radiation-resistance	5 × 10 <sup>8</sup> cJ/kg
Burning behavior	Flame-retardant according to VDE 0482 part 265-2; DIN EN 50265-2; IEC 60332-1, UL 1581 section Cable Flame-Test, CSA FT 1
Halogen free	according to EN 50267-2-1

### Construction

- Bare copper wire, super finely stranded according to DIN VDE 0295 class 6, IEC 60228 class 6
- Conductor insulation Special TPE, high glide
- Conductors black with white number print according to DIN EN 50334
- Ground conductor green/yellow according to DIN EN 50334 in the top layer  
G = with green/yellow ground conductor, × = without ground conductor
- Conductors cabled in layers without mechanical stress, layer pitch optimised
- Fleece wrap over cable core
- Sub jacket TPE
- Braid from tinned copper wire, optical coverage ≥ 85 %
- Jacket full PUR
- Jacket color grey RAL 7001

Part-No.	Number of conductors/cross-section	Outer $\varnothing$ ca. mm	Weight kg/100 m	Cu-Index kg/100 m
<b>1.0 mm<sup>2</sup></b>				
113360	(3G1.0)	9.0	10.8	4.7
113361	(4G1.0)	9.6	12.6	5.8
113362	(5G1.0)	10.4	14.6	7.8
113363	(7G1.0)	11.8	19.7	10.1
113364	(12G1.0)	13.8	27.4	15.8
113365	(18G1.0)	15.7	37.7	22.4
113366	(25G1.0)	18.5	51.9	33.2
<b>1.5 mm<sup>2</sup></b>				
113346	(2×1.5)	9.3	11.5	4.7
113318	(3G1.5)	9.7	13.1	6.3
113331	(4G1.5)	10.5	16.0	8.7
113319	(5G1.5)	11.2	18.7	10.4
113320	(7G1.5)	12.8	24.2	13.8
113321	(12G1.5)	14.9	35.4	22.0
113322	(18G1.5)	17.2	48.7	32.4
113323	(25G1.5)	20.1	65.3	46.3
<b>2.5 mm<sup>2</sup></b>				
113341	(3G2.5)	10.9	18.4	9.6
113332	(4G2.5)	11.8	22.3	12.9
113339	(5G2.5)	12.6	25.9	15.7
113340	(7G2.5)	14.6	35.2	21.2
113344	(12G2.5)	17.4	52.9	35.6
113342	(18G2.5)	19.9	73.1	53.2



## 2. Electronic cables

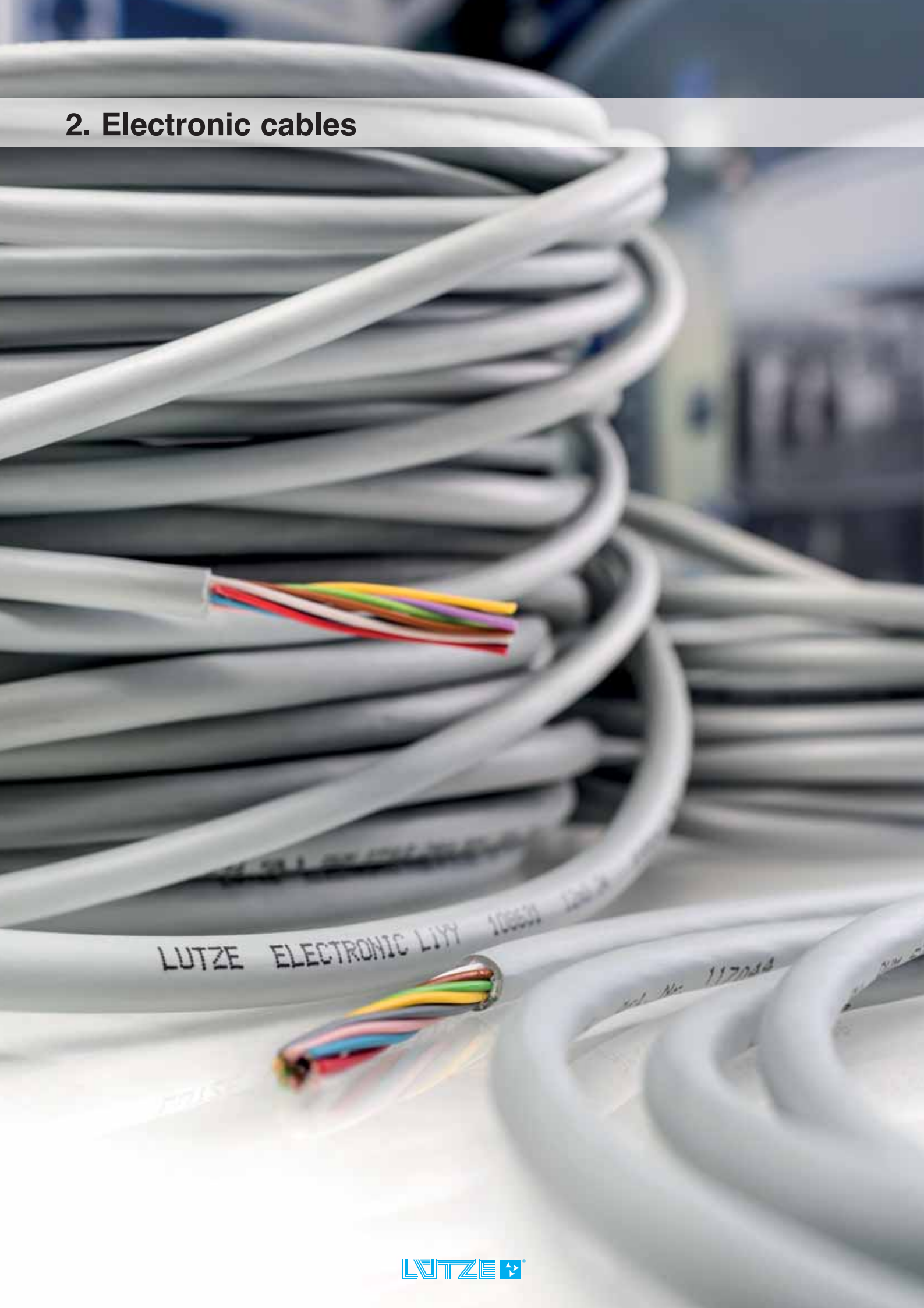

LUTZE ELECTRONIC LIYY 10050 10050

Lot No 117084

## 2. Electronic cables

	Jacket	Shielding	Approval	Application	
LÜTZE ELECTRONIC LiYY	PVC		CE	For Stationary and Flexible Applications within Machine- and Plant Wiring	2.3
LÜTZE ELECTRONIC LiY (C) Y	PVC	•	CE	For Stationary and Flexible Applications within Machine- and Plant Wiring	2.4
LÜTZE ELECTRONIC LiY (C) Y TP	PVC	•	CE	For Stationary and Flexible Applications within Machine- and Plant Wiring	2.5
LÜTZE ELECTRONIC LiYY	PVC		CE, UL	For Stationary and Flexible Applications within Machine- and Plant Wiring International approvals	2.6
LÜTZE ELECTRONIC LiY (C) Y	PVC	•	CE, UL	For Stationary and Flexible Applications within Machine- and Plant Wiring International approvals	2.7
LÜTZE ELECTRONIC LiY (C) Y TP	PVC	•	CE, UL	For Stationary and Flexible Applications within Machine- and Plant Wiring International approvals	2.8
LÜTZE SUPERFLEX® TRONIC PUR	PUR		CE, UL	Continuous Moving in Drag Chains For highest requirements and extremely harsh operating conditions	2.10
LÜTZE SUPERFLEX® TRONIC (C) PUR	PUR	•	CE, UL	Continuous Moving in Drag Chains For highest requirements and extremely harsh operating conditions	2.11
LÜTZE SUPERFLEX® TRONIC (C) PUR TP	PUR	•	CE, UL	Continuous Moving in Drag Chains For highest requirements and extremely harsh operating conditions	2.12

# PVC electronic cables - unshielded

## LÜTZE ELECTRONIC LiYY Unshielded electronic cable



### Application

- In all areas of electronics, measuring, control and regulation technologies
- In low voltage switchgears, communications engineering
- In dry and damp rooms
- For flexible application for free movement and without tensile loading

### Properties

- PVC Flame-retardant, self-extinguishing
- Resistant to most oils, greases, acids and alkalis
- Silicone free
- RoHS-compliant

### Technical data

#### Voltage

up to 0.34 mm <sup>2</sup>	300 V
from 1,5 mm <sup>2</sup>	500 V

#### Test voltage

up to 0.34 mm <sup>2</sup>	1200 V
after 0.5 mm <sup>2</sup>	2000 V

Insulation resistance min. 20 MΩ × km

Operating capacitance approx. 120 – 150 pF/m

#### Temperature range

moving	-5 °C to +70 °C
fixed	-30 °C to +70 °C

#### Minimum bending radius

moving	D × 12
fixed	D × 4

#### Burning behavior

Flame-retardant according to VDE 0482 part 265-2, DIN EN 50265-2, IEC 60332-1

### Construction

- Bare copper wire, finely stranded according to DIN VDE 0295 class 5, IEC 60228 class 5  
(\*exception: 0.34 mm<sup>2</sup> = 7×0.25∅)
- Conductor insulation Special PVC
- Conductors color-coded according to DIN 47100
- Conductors cabled in layers
- Jacket special PVC TM2 according to VDE 0281-1, matte, adhesion-free surface
- Jacket color grey RAL 7001

Part-No.	Number of conductors/cross-section	Outer Ø ca. mm	Weight kg/100 m	Cu-Index kg/100 m
<b>0.14 mm<sup>2</sup></b>				
110000	3×0.14	3.4	1.5	0.4
110001	4×0.14	3.6	1.7	0.5
110002	5×0.14	3.9	2.2	0.7
110003	6×0.14	4.2	2.5	0.8
110004	7×0.14	4.2	2.6	0.9
110415	8×0.14	4.5	2.9	1.1
110005	10×0.14	5.2	3.5	1.3
110006	12×0.14	5.6	4.3	1.6
110008	16×0.14	6.1	5.2	2.2
110009	18×0.14	6.4	5.7	2.4
110010	20×0.14	6.9	7.3	2.7
110011	24×0.14	7.6	8.9	3.2
<b>0.25 mm<sup>2</sup></b>				
110988	2×0.25	3.8	2.5	0.5
110070	3×0.25	4.0	2.9	0.7
110071	4×0.25	4.3	3.1	1.0
110072	5×0.25	4.7	3.8	1.2
110073	6×0.25	5.1	4.2	1.4
110089	7×0.25	5.1	4.8	1.7
110074	8×0.25	5.7	5.4	1.9
110075	10×0.25	6.8	6.5	2.4
110076	12×0.25	7.0	7.5	2.9
110078	16×0.25	7.7	9.5	3.8
110079	18×0.25	8.1	9.9	4.3
110080	20×0.25	8.5	11.5	4.8
110081	24×0.25	9.4	14.3	5.8
<b>0.34 mm<sup>2</sup> *</b>				
110927	2×0.34	4.2	2.8	0.7
110122	3×0.34	4.4	3.0	1.0
110123	4×0.34	4.8	4.0	1.3
110249	5×0.34	5.5	4.4	1.6
110125	6×0.34	5.9	5.3	2.0
110127	8×0.34	6.4	6.5	2.6
110129	10×0.34	7.6	7.7	3.3
110131	12×0.34	7.8	9.7	3.9
110719	16×0.34	8.7	11.4	5.2
110135	18×0.34	9.1	13.5	5.9
110945	20×0.34	9.6	14.6	6.5
<b>0.5 mm<sup>2</sup></b>				
108125	2×0.5	4.7	2.5	1.0
100327	3×0.5	5.0	3.5	1.4
100338	4×0.5	5.6	4.2	1.9
101052	5×0.5	6.1	4.9	2.4
100918	6×0.5	6.9	6.5	2.9
108126	7×0.5	6.9	7.3	3.4
100920	8×0.5	7.4	8.3	3.8
100922	10×0.5	8.6	12.0	4.8
100964	12×0.5	9.0	13.0	5.8
100948	16×0.5	10.2	15.2	7.7
108128	20×0.5	11.3	18.0	9.6
100951	24×0.5	12.5	25.0	12.0

CE These products are in conformity with the EU Low Voltage Directive 2006/95/EC

# PVC electronic cables - shielded

## LÜTZE ELECTRONIC LiY (C) Y Shielded electronic cable



### Application

- For interference-free transmission in all areas of electronics, measuring, control and regulation technology
- In low voltage switchgears and communications engineering
- In dry and damp rooms
- For flexible application for free movement and without tensile loading

### Properties

- PVC Flame-retardant, self-extinguishing
- High active and passive interference resistance (EMC)
- Resistant to most acids and alkalis
- Silicone free
- RoHS-compliant

### Technical data

Voltage	
up to 0.34 mm <sup>2</sup>	300 V
from 1,5 mm <sup>2</sup>	500 V
Test voltage	
up to 0.34 mm <sup>2</sup>	1200 V
after 0.5 mm <sup>2</sup>	2000 V
Insulation resistance	min. 20 MΩ × km
Operating capacitance	approx. 120 – 150 pF/m
Temperature range	
moving	-5 °C to +70 °C
fixed	-30 °C to +70 °C
Minimum bending radius	
moving	D × 15
fixed	D × 6
Burning behavior	
	Flame-retardant according to VDE 0482 part 265-2, DIN EN 50265-2, IEC 60332-1

### Construction

- Bare copper wire, finely stranded according to DIN VDE 0295 class 5, IEC 60228 class 5  
(\*exception: 0.34 mm<sup>2</sup> = 7×0.25Ø)
- Conductor insulation Special PVC
- Conductors color-coded according to DIN 47100
- Conductors cabled in layers, foil tape
- Braid from tinned copper wire, optical coverage ≥ 80 %
- Jacket special PVC TM2 according to VDE 0281-1, matte, adhesion-free surface
- Jacket color grey RAL 7001

Part-No.	Number of conductors/cross-section	Outer Ø ca. mm	Weight kg/100 m	Cu-Index kg/100 m
<b>0.14 mm<sup>2</sup></b>				
111206	(2×0.14)	3.7	2.1	1.3
108147	(3×0.14)	3.9	2.5	1.4
108149	(4×0.14)	4.1	2.9	1.6
110929	(5×0.14)	4.4	3.5	2.0
111086	(6×0.14)	4.7	3.8	2.2
110658	(7×0.14)	4.7	4.1	2.4
110722	(8×0.14)	5.0	4.5	2.6
110710	(10×0.14)	5.9	5.6	2.9
110736	(12×0.14)	6.1	6.1	3.2
118466	(16×0.14)	6.8	8.1	4.9
118481	(18×0.14)	7.1	9.2	5.4
110478	(21×0.14)	7.4	10.6	6.0
118438	(25×0.14)	8.3	12.0	7.8
<b>0.25 mm<sup>2</sup></b>				
110993	(2×0.25)	4.3	2.0	1.5
118430	(3×0.25)	4.5	3.5	1.8
118439	(4×0.25)	4.8	4.4	2.2
108154	(5×0.25)	5.2	5.0	2.5
118406	(6×0.25)	5.8	5.8	3.0
110650	(7×0.25)	5.8	6.0	3.2
118407	(8×0.25)	6.2	6.7	3.5
110475	(10×0.25)	7.3	8.1	4.2
118467	(12×0.25)	7.5	9.1	5.0
111082	(14×0.25)	7.8	11.6	6.4
100552	(16×0.25)	8.2	13.3	7.1
118476	(18×0.25)	8.6	13.7	8.0
111327	(21×0.25)	9.0	17.1	10.5
110471	(25×0.25)	10.7	19.0	11.7
<b>0.34 mm<sup>2</sup> *</b>				
110787	(2×0.34)	4.7	3.3	1.7
110371	(3×0.34)	4.9	4.1	2.1
110743	(4×0.34)	5.5	4.8	2.5
118408	(5×0.34)	6.0	5.8	3.0
118409	(6×0.34)	6.4	6.4	3.6
118410	(7×0.34)	6.4	7.0	4.2
118411	(8×0.34)	7.1	9.3	4.5
118421	(10×0.34)	8.1	11.0	6.3
110790	(12×0.34)	8.3	12.0	7.0
101280	(16×0.34)	9.2	14.7	8.7
110717	(18×0.34)	10.2	17.2	10.8
118427	(21×0.34)	10.7	19.6	12.7
101281	(24×0.34)	11.7	22.9	14.0
<b>0.5 mm<sup>2</sup></b>				
118320	(2×0.5)	5.2	4.2	2.9
118413	(3×0.5)	5.7	5.5	3.5
118412	(4×0.5)	6.1	6.8	4.5
110720	(5×0.5)	6.8	8.2	5.0
110374	(7×0.5)	7.4	10.9	6.8
118471	(8×0.5)	7.9	12.3	7.5
101423	(10×0.5)	9.1	13.5	9.3
118991	(12×0.5)	9.4	16.0	10.7
110742	(18×0.5)	11.5	23.0	15.2
110514	(25×0.5)	13.5	33.5	21.1

CE These products are in conformity with the EU Low Voltage Directive 2006/95/EC

# PVC electronic cables - shielded

## LÜTZE ELECTRONIC LiY (C) Y TP Shielded electronic cable, paired



### Application

- For interference-free transmission in all areas of electronics, measuring, monitoring and control technology
- In low voltage switchgear, communications engineering
- In dry and damp rooms
- For flexible use with free movement without tensile load

### Properties

- PVC Flame-retardant, self-extinguishing
- High active and passive interference resistance (EMC)
- High crosstalk attenuation due to twisted pairs
- Resistant to most oils, greases, acids and alkalis
- Silicone free
- RoHS-compliant

### Technical data

#### Voltage

up to 0.34 mm <sup>2</sup>	300 V
from 1,5 mm <sup>2</sup>	500 V

#### Test voltage

up to 0.34 mm <sup>2</sup>	1200 V
after 0.5 mm <sup>2</sup>	2000 V

Insulation resistance min. 20 MΩ × km

Operating capacitance approx. 120 – 150 pF/m

#### Temperature range

moving	-5 °C to +70 °C
fixed	-30 °C to +70 °C

#### Minimum bending radius

moving	D × 15
fixed	D × 6

#### Burning behavior

Flame-retardant according to VDE 0482 part 265-2; DIN EN 50265-2; IEC 60332-1

### Construction

- Bare copper wire, finely stranded according to DIN VDE 0295 class 5, IEC 60228 class 5  
(\*exception: 0.34 mm<sup>2</sup> = 7×0.25∅)
- Conductor insulation Special PVC
- Conductors color-coded according to DIN 47100
- Conductors stranded pairs, foil tape
- Braid from tinned copper wire, optical coverage ≥ 80 %
- Jacket special PVC TM2 according to VDE 0281-1, matte, adhesion-free surface
- Jacket color grey RAL 7032

Part-No.	Number of conductors/cross-section	Outer Ø ca. mm	Weight kg/100 m	Cu-Index kg/100 m
<b>0.14 mm<sup>2</sup></b>				
110600	(2×2×0.14)	5.3	3.4	1.9
110601	(3×2×0.14)	5.8	4.3	2.3
110602	(4×2×0.14)	6.2	5.0	3.2
101321	(5×2×0.14)	6.4	7.0	3.7
110604	(6×2×0.14)	7.1	8.1	4.8
110659	(8×2×0.14)	7.6	9.3	6.2
110606	(10×2×0.14)	8.7	11.5	7.1
110607	(12×2×0.14)	8.9	12.5	10.1
110609	(16×2×0.14)	10.2	14.8	11.9
<b>0.25 mm<sup>2</sup></b>				
110618	(2×2×0.25)	6.3	4.6	2.8
110619	(3×2×0.25)	7.1	6.4	3.4
110620	(4×2×0.25)	7.6	7.3	4.0
118195	(5×2×0.25)	7.9	8.8	5.0
110622	(6×2×0.25)	8.5	9.8	6.8
118251	(8×2×0.25)	9.2	11.8	8.4
110625	(10×2×0.25)	11.2	16.5	11.0
110626	(12×2×0.25)	11.5	19.0	12.8
110629	(20×2×0.25)	13.9	28.9	18.7
<b>0.34 mm<sup>2</sup> *</b>				
110633	(2×2×0.34)	7.1	6.4	3.1
110634	(3×2×0.34)	7.8	8.6	4.6
110635	(4×2×0.34)	8.5	11.3	6.1
110637	(6×2×0.34)	9.5	13.7	7.8
118252	(8×2×0.34)	10.8	16.1	9.7
110665	(10×2×0.34)	12.5	23.0	13.1
118297	(25×2×0.34)	18.3	45.5	26.6
<b>0.5 mm<sup>2</sup></b>				
110641	(2×2×0.5)	7.9	7.5	5.4
110642	(3×2×0.5)	8.7	9.8	7.0
110643	(4×2×0.5)	9.4	12.3	9.1
110248	(5×2×0.5)	10.5	15.4	10.5
110660	(6×2×0.5)	11.1	16.2	12.0
110645	(8×2×0.5)	12.2	19.0	14.4
118244	(10×2×0.5)	14.1	25.6	17.8
118322	(12×2×0.5)	14.9	35.2	19.9
110647	(16×2×0.5)	16.5	40.0	25.1

CE These products are in conformity with the EU Low Voltage Directive 2006/95/EC

# PVC electronic cables - unshielded

## LÜTZE ELECTRONIC LiYY

### Unshielded electronic cable UL recognized



#### Application

- In all areas of electronics, measuring, monitoring and regulation technologies
- In low voltage switchgears, communications engineering
- In dry and damp rooms
- For flexible application for free movement and without tensile loading

#### Properties

- Minimal cable diameter due to thin-walled PVC conductor insulation according to UL
- Outer jacket special-PVC Class 43 according to UL
- Very good oil resistance
- Resistant to most acids and alkalis (see tech. information)
- Silicone free
- RoHS-compliant

#### Technical data

UL approval	AWM 2464
Nominal voltage	300 V 80 °C
Test voltage	2000 V
Insulation resistance	min. 20 MΩ × km
Temperature range	
moving	-10 °C to +70 °C
fixed	-40 °C to +80 °C
Minimum bending radius	
moving	D × 12
fixed	D × 4
Burning behavior	Flame-retardant according to VDE 0482 part 265-2, DIN EN 50265-2, IEC 60332-1, UL 1581 section VW-1 Flame-Test, CSA FT 1

#### Construction

- Bare copper wire, finely stranded according to DIN VDE 0295 class 5, IEC 60228 class 5  
(\*exception: 0.34 mm<sup>2</sup> = 7×0.25Ø)
- Conductor insulation Special PVC
- Conductors color-coded according to DIN 47100
- Conductors cabled in layers
- Jacket special-PVC
- Jacket color grey RAL 7001

Part-No.	Number of conductors/cross-section	Outer Ø ca. mm	Weight kg/100 m	Cu-Index kg/100 m
<b>0.14 mm<sup>2</sup></b>				
108600	2×0.14	3.6	1.9	0.3
108601	3×0.14	3.8	2.2	0.4
108602	4×0.14	4.0	2.5	0.5
108603	5×0.14	4.3	2.4	0.7
108604	6×0.14	4.6	2.9	0.8
108605	8×0.14	5.0	3.6	1.1
108606	10×0.14	5.6	4.3	1.4
108607	12×0.14	5.8	4.8	1.6
108608	16×0.14	6.3	5.9	2.2
108609	18×0.14	6.6	6.5	2.4
108610	25×0.14	7.6	8.6	3.4
<b>0.25 mm<sup>2</sup></b>				
108612	2×0.25	4.2	2.7	0.5
108613	3×0.25	4.4	3.1	0.7
108614	4×0.25	4.7	3.6	1.0
108615	5×0.25	5.1	4.2	1.2
108616	6×0.25	5.5	5.1	1.4
108617	8×0.25	5.9	5.9	1.9
108618	10×0.25	6.8	7.0	2.4
108619	12×0.25	7.0	8.0	2.9
108620	16×0.25	7.5	10.2	3.8
108621	18×0.25	8.1	10.7	4.3
108622	25×0.25	9.6	14.6	6.0
<b>0.34 mm<sup>2</sup>*</b>				
108624	2×0.34	4.7	3.4	0.7
108625	3×0.34	5.0	4.0	1.0
108626	4×0.34	5.4	4.7	1.3
108627	5×0.34	5.7	5.5	1.6
108628	6×0.34	6.3	6.4	2.0
108629	8×0.34	6.8	7.4	2.6
108630	10×0.34	7.8	8.9	3.3
108631	12×0.34	8.1	10.5	3.9
108632	16×0.34	9.0	13.6	5.2
108633	18×0.34	9.5	14.9	5.9
108634	25×0.34	11.3	19.9	8.2
<b>0.5 mm<sup>2</sup></b>				
108636	2×0.5	5.0	4.0	1.0
108637	3×0.5	5.4	4.9	1.5
108638	4×0.5	5.8	5.7	2.0
108639	5×0.5	6.3	6.7	2.4
108640	6×0.5	6.9	7.8	2.9
108641	8×0.5	7.4	9.5	3.8
108642	10×0.5	8.6	11.3	4.8
108643	12×0.5	9.1	13.1	5.8
108644	16×0.5	10.3	17.0	7.7
108645	18×0.5	11.0	20.7	8.6
108646	25×0.5	12.8	26.3	12.0
<b>0.75 mm<sup>2</sup></b>				
108648	2×0.75	5.6	3.7	1.4
108649	3×0.75	5.9	4.5	2.2
108650	4×0.75	6.4	5.5	2.9
108651	5×0.75	7.0	7.0	3.6
108652	6×0.75	7.4	7.6	4.3
108653	8×0.75	8.5	9.5	5.8
108654	10×0.75	9.8	11.5	7.2
108655	12×0.75	10.1	13.3	8.6
108656	16×0.75	11.2	16.9	11.5
108657	18×0.75	11.8	18.9	13.0
108658	25×0.75	14.4	25.8	18.0

CE These products are in conformity with the EU Low Voltage Directive 2006/95/EC

# PVC electronic cables - shielded

## LÜTZE ELECTRONIC LiY (C) Y Shielded electronic cable UL recognized



### Application

- For interference-free transmission in all areas of electronics, measuring, monitoring and regulation technology
- In low voltage switchgears, communications engineering
- In dry and damp rooms
- For flexible application for free movement and without tensile loading
- Especially for industrial environments with high interference potential in machine, plant and device construction

### Properties

- Minimal cable diameter due to thin-walled PVC conductor insulation according to UL
- High active and passive interference resistance
- Outer jacket special-PVC Class 43 according to UL
- Very good oil resistance
- Resistant to most acids and alkalis (see tech. information)
- Silicone free
- RoHS-compliant

### Technical data

UL approval	AWM 2464
Nominal voltage	300 V 80 °C
Test voltage	2000 V
Insulation resistance	min. 20 MΩ × km
Operating capacitance	approx. 120 – 150 pF/m
Temperature range	
moving	-10 °C to +70 °C
fixed	-40 °C to +80 °C
Minimum bending radius	
moving	D × 15
fixed	D × 6
Burning behavior	Flame-retardant according to VDE 0482 part 265-2, DIN EN 50265-2, IEC 60332-1, UL 1581 section VW-1 Flame-Test, CSA FT 1

### Construction

- Bare copper wire, finely stranded according to DIN VDE 0295 class 5, IEC 60228 class 5
- (\*exception: 0.34 mm<sup>2</sup> = 7×0.25∅)
- Conductor insulation Special PVC
- Conductors color-coded according to DIN 47100
- Conductors cabled in layers
- Braid from tinned copper wire, optical coverage ≥ 85 %
- Jacket special-PVC
- Jacket color grey RAL 7001

Part-No.	Number of conductors/cross-section	Outer Ø ca. mm	Weight kg/100 m	Cu-Index kg/100 m
<b>0.14 mm<sup>2</sup></b>				
108670	(2×0.14)	4.1	2.7	1.2
108671	(3×0.14)	4.3	3.0	1.3
108672	(4×0.14)	4.5	3.4	1.5
108673	(5×0.14)	4.8	4.0	1.7
108674	(6×0.14)	5.1	4.3	2.0
108675	(8×0.14)	5.6	5.1	2.4
108676	(10×0.14)	6.1	6.0	2.9
108677	(12×0.14)	6.2	6.5	3.2
108678	(16×0.14)	6.9	9.0	3.9
108679	(18×0.14)	7.3	11.5	4.3
108680	(25×0.14)	8.6	15.4	5.5
<b>0.25 mm<sup>2</sup></b>				
108682	(2×0.25)	4.7	3.2	1.5
108683	(3×0.25)	4.9	3.7	1.8
108684	(4×0.25)	5.2	4.4	2.2
108685	(5×0.25)	5.6	5.2	2.6
108686	(6×0.25)	6.0	6.1	2.9
108687	(8×0.25)	6.5	6.8	3.6
108688	(10×0.25)	7.5	8.0	4.3
108689	(12×0.25)	7.7	9.2	5.0
108690	(16×0.25)	8.4	11.9	6.4
108691	(18×0.25)	9.1	12.9	8.0
108692	(25×0.25)	10.6	17.2	9.8
<b>0.34 mm<sup>2</sup> *</b>				
108694	(2×0.34)	5.2	4.0	2.1
108695	(3×0.34)	5.4	4.3	2.2
108696	(4×0.34)	5.8	5.8	2.7
108697	(5×0.34)	6.2	6.6	3.2
108698	(6×0.34)	6.8	7.9	3.9
108699	(8×0.34)	7.2	8.9	4.5
108700	(10×0.34)	8.6	11.6	6.3
108701	(12×0.34)	8.8	12.6	6.7
108702	(16×0.34)	9.4	16.0	7.7
108703	(18×0.34)	10.1	17.3	9.2
108704	(25×0.34)	11.8	24.7	12.1
<b>0.5 mm<sup>2</sup></b>				
108706	(2×0.5)	5.6	4.7	2.2
108707	(3×0.5)	5.9	5.6	2.8
108708	(4×0.5)	6.3	6.7	3.4
108709	(5×0.5)	6.9	7.8	4.4
108710	(6×0.5)	7.5	9.1	6.8
108711	(8×0.5)	8.0	10.2	8.5
108712	(10×0.5)	9.0	13.7	10.0
108713	(12×0.5)	9.7	16.8	11.2
108714	(16×0.5)	10.7	20.3	14.0
108715	(18×0.5)	11.4	22.8	15.2
108716	(25×0.5)	13.6	30.0	19.5
<b>0.75 mm<sup>2</sup></b>				
108718	(2×0.75)	6.1	6.4	3.8
108719	(3×0.75)	6.5	7.6	4.9
108720	(4×0.75)	7.0	9.2	5.8
108721	(5×0.75)	7.5	10.9	6.7
108722	(6×0.75)	8.3	11.3	8.7
108723	(8×0.75)	8.9	14.5	11.0
108724	(10×0.75)	10.6	18.7	13.0
108725	(12×0.75)	10.7	21.8	15.4
108726	(16×0.75)	12.0	27.5	18.3
108727	(18×0.75)	12.9	32.7	19.5
108728	(25×0.75)	15.4	45.4	28.0

CE These products are in conformity with the EU Low Voltage Directive 2006/95/EC

# PVC electronic cables - shielded

## LÜTZE ELECTRONIC LiY (C) Y TP

### Shielded electronic cable UL recognized, paired



#### Application

- For interference-free transmission in all areas of electronics, measuring, monitoring and regulation technology
- In low voltage switchgears, communications engineering
- In dry and damp rooms
- For flexible application for free movement and without tensile loading
- Especially for industrial environments with high interference potential in machine, plant and device construction

#### Properties

- Minimal cable diameter due to thin-walled PVC conductor insulation according to UL
- High active and passive interference resistance
- Outer jacket special-PVC Class 43 according to UL
- Very good oil resistance
- Resistant to most acids and alkalis (see tech. information)
- Silicone free
- RoHS-compliant

#### Technical data

UL approval	AWM 2464
Nominal voltage	300 V 80 °C
Test voltage	2000 V
Insulation resistance	min. 20 MΩ × km
Operating capacitance	approx. 120 – 150 pF/m
Temperature range	
moving	-10 °C to +70 °C
fixed	-40 °C to +80 °C
Minimum bending radius	
moving	D × 15
fixed	D × 6
Burning behavior	Flame-retardant according to VDE 0482 part 265-2, DIN EN 50265-2, IEC 60332-1, UL 1581 section VW-1 Flame-Test, CSA FT 1

#### Construction

- Bare copper wire, finely stranded according to DIN VDE 0295 class 5, IEC 60228 class 5 (\*exception: 0.34 mm<sup>2</sup> = 7×0.25Ø)
- Conductor insulation Special PVC
- Conductors color-coded according to DIN 47100
- Conductors paired, pairs cabled in layers
- Braid from tinned copper wire, optical coverage ≥ 85 %
- Jacket special-PVC
- Jacket color grey RAL 7001

Part-No.	Number of conductors/cross-section	Outer Ø ca. mm	Weight kg/100 m	Cu-Index kg/100 m
<b>0.25 mm<sup>2</sup></b>				
108751	(2x2×0.25)	6.0	4.9	2.8
108753	(4x2×0.25)	7.3	8.2	4.0
108754	(5x2×0.25)	7.9	8.7	5.0
108755	(6x2×0.25)	8.1	9.5	7.0
108756	(8x2×0.25)	9.3	12.7	7.5
<b>0.34 mm<sup>2</sup> *</b>				
108761	(2x2×0.34)	6.7	6.1	2.6
108763	(4x2×0.34)	8.4	12.8	6.1
108764	(5x2×0.34)	9.4	12.5	6.6
108765	(6x2×0.34)	9.9	13.7	7.5
108766	(8x2×0.34)	10.8	17.1	9.7
<b>0.5 mm<sup>2</sup></b>				
108771	(2x2×0.5)	7.7	7.9	4.6
108773	(4x2×0.5)	9.7	13.4	8.7
108774	(5x2×0.5)	10.2	14.9	10.4
108775	(6x2×0.5)	11.1	18.6	11.8
108776	(8x2×0.5)	12.5	21.8	14.0
<b>0.75 mm<sup>2</sup></b>				
108934	(2x2×0.75)	8.5	10.2	6.7
108935	(4x2×0.75)	10.7	14.9	11.0
108936	(5x2×0.75)	11.6	22.2	12.6
108937	(6x2×0.75)	12.7	23.0	14.6
108938	(8x2×0.75)	13.2	27.0	18.0

CE These products are in conformity with the EU Low Voltage Directive 2006/95/EC



# LÜTZE SUPERFLEX® and LÜTZE SUPERFLEX® PLUS



## LÜTZE SUPERFLEX®

← *connected*

**LÜTZE SUPERFLEX® sets Industry Standards:  
longevity, reliability, flexibility**

LÜTZE SUPERFLEX® flexing cables are specifically designed for use in continuous motion applications such as drag chains.

Find here more informations  
about LÜTZE SUPERFLEX®  
<http://bit.ly/ZUdgUK>



# PUR electronic cables - C-track compatible - Unshielded

## LÜTZE SUPERFLEX® TRONIC PUR Unshielded electronic cable UL recognized For highest requirements



### Application

- Robots, drag chains as well as everywhere where signals are transmitted to continuously moving system or machine parts
- Machine and device construction, transport and conveyor technology, heating, climate technology
- In dry and damp rooms
- As monitoring, measurement and control cable for continuous flexing applications

### Properties

- Low capacitance, very good electrical properties
- Flame-retardant, self-extinguishing
- Halogen-free, no corrosive gases
- Very good alternating bending strength
- Low adhesion, abrasion-resistant, nick-resistant, tear resistant
- Hydrolysis-resistant, microbe-resistant, and rot-resistant
- Good ruggedness and salt water resistance
- Excellent coolant and lubricant resistance
- Resistant to most oils, greases, alcohol-free benzines and kerosene
- Silicone free
- RoHS-compliant

### Technical data

UL approval	AWM 20549
Nominal voltage	300 V 80 °C
Test voltage	3000 V
Insulation resistance	min. 1000 MΩ × km
Temperature range	
moving	-25 °C to +80 °C
fixed	-40 °C to +80 °C
Minimum bending radius	
moving	D × 10
fixed	D × 4
Burning behavior	Flame-retardant according to DIN EN 60332-2-2, UL Horizontal Flame Test
Halogen free	according to EN 50267-2-1

### Construction

- Bare copper wire, super finely stranded according to DIN VDE 0295 class 6, IEC 60228 class 6
- Conductor insulation Special TPE, high glide
- Conductors color-coded according to DIN 47100
- Conductors cabled in layers without mechanical stress, layer pitch optimised
- Fleece wrap over cable core
- Jacket special-PUR, matte, adhesion-free surface
- Jacket color grey RAL 7001

Part-No.	Number of conductors/cross-section	Outer Ø ca. mm	Weight kg/100 m	Cu-Index kg/100 m
<b>AWG 26 / 0,14 mm<sup>2</sup></b>				
117030	2×0.14	3.6	1.4	0.3
117031	3×0.14	3.7	1.6	0.4
117032	4×0.14	4.1	1.9	0.6
117033	5×0.14	4.4	2.2	0.7
117034	7×0.14	5.0	2.9	1.0
117035	10×0.14	5.7	3.7	1.4
117036	12×0.14	5.9	4.1	1.7
117027	15×0.14	6.5	4.9	2.2
117037	18×0.14	6.8	5.7	2.7
117038	25×0.14	8.1	7.9	3.6
<b>AWG 24 / 0,25 mm<sup>2</sup></b>				
117039	2×0.25	3.8	1.8	0.5
117040	3×0.25	4.0	2.1	0.8
117041	4×0.25	4.4	2.5	1.0
117042	5×0.25	4.7	2.9	1.3
117043	7×0.25	5.4	3.8	1.8
117044	10×0.25	6.3	5.0	2.5
117045	12×0.25	6.4	5.6	3.0
117028	15×0.25	7.1	6.5	3.5
117046	18×0.25	7.4	7.9	4.5
117047	25×0.25	8.8	10.8	6.3
<b>AWG 22 / 0,34 mm<sup>2</sup></b>				
117048	2×0.34	4.1	2.1	0.7
117049	3×0.34	4.3	2.4	1.0
117050	4×0.34	4.6	2.9	1.3
117051	5×0.34	5.0	3.4	1.7
117052	7×0.34	5.7	4.5	2.4
117053	10×0.34	6.7	5.9	3.4
117054	12×0.34	6.9	6.8	4.0
117029	15×0.34	7.6	8.4	5.0
117055	18×0.34	7.9	9.6	6.1
117056	25×0.34	9.5	13.2	8.4

CE These products are in conformity with the EU Low Voltage Directive 2006/95/EC

# PVC electronic cables - C-track compatible - Shielded

## LÜTZE SUPERFLEX® TRONIC (C) PUR Shielded electronic cable UL recognized For highest requirements



### Application

- Robots, drag chains as well as everywhere where signals are transmitted to continuously moving system or machine parts
- Machine and device construction, transport and conveyor technology, heating, climate technology
- In dry and damp rooms
- As monitoring, measurement and control cable for continuous flexing applications
- Especially for industrial environments with high EMI potential in machine, plant and device construction

### Properties

- High active and passive interference resistance (EMC)
- Braided shield optimised for continuous flexing applications
- Low capacitance, very good electrical properties
- Flame-retardant, self-extinguishing
- Halogen-free, no corrosive gases
- Very good alternating bending strength
- Low adhesion, abrasion-resistant, nick-resistant, tear resistant
- Hydrolysis-resistant, microbe-resistant, and rot-resistant
- Good ruggedness and salt water resistance
- Excellent coolant and lubricant resistance
- Resistant to most oils, greases, alcohol-free benzines and kerosene
- Silicone free
- RoHS-compliant

### Technical data

UL approval	AWM 20549
Nominal voltage	300 V 80 °C
Test voltage	3000 V
Insulation resistance	min. 1000 MΩ × km
Temperature range	
moving	-25 °C to +80 °C
fixed	-40 °C to +80 °C
Minimum bending radius	
moving	D × 12
fixed	D × 6
Burning behavior	Flame-retardant according to DIN EN 60332-2-2, UL Horizontal Flame Test
Halogen free	according to EN 50267-2-1

### Construction

- Bare copper wire, super finely stranded according to DIN VDE 0295 class 6, IEC 60228 class 6
- Conductor insulation Special-TPE
- Conductors color-coded according to DIN 47100
- Conductors cabled in layers without mechanical stress, layer pitch optimised
- Fleece wrap over cable core
- Braid from tinned copper wire, optical coverage ≥ 85 %
- Jacket special-PUR, matte, adhesion-free surface
- Jacket color grey RAL 7001

Part-No.	Number of conductors/cross-section	Outer Ø ca. mm	Weight kg/100 m	Cu-Index kg/100 m
<b>0.14 mm<sup>2</sup></b>				
117090	(2×0.14)	4.0	2.0	1.0
117091	(3×0.14)	4.2	2.3	1.2
117092	(4×0.14)	4.5	2.6	1.4
117093	(5×0.14)	4.8	3.0	1.7
117094	(7×0.14)	5.5	3.9	2.1
117095	(10×0.14)	6.2	4.8	2.8
117096	(12×0.14)	6.3	5.3	3.1
117097	(18×0.14)	7.2	7.1	4.2
117098	(25×0.14)	8.5	9.4	5.6
<b>0.25 mm<sup>2</sup></b>				
117099	(2×0.25)	4.3	2.4	1.3
117100	(3×0.25)	4.5	2.8	1.6
117101	(4×0.25)	4.8	3.3	1.9
117102	(5×0.25)	5.1	3.7	2.3
117103	(7×0.25)	5.8	4.8	3.0
117104	(10×0.25)	6.7	6.1	4.0
117105	(12×0.25)	6.8	6.8	5.3
117106	(18×0.25)	7.8	9.4	6.3
117107	(25×0.25)	9.4	13.2	9.5
<b>0.34 mm<sup>2</sup></b>				
117108	(2×0.34)	4.5	2.6	1.5
117109	(3×0.34)	4.7	2.1	1.9
117110	(4×0.34)	5.0	3.7	2.3
117111	(5×0.34)	5.4	4.3	2.8
117112	(7×0.34)	6.2	5.7	3.7
117113	(10×0.34)	7.1	7.2	5.0
117114	(12×0.34)	7.3	8.0	5.6
117115	(18×0.34)	8.4	11.2	8.0
117116	(25×0.34)	10.0	15.8	11.5

CE These products are in conformity with the EU Low Voltage Directive 2006/95/EC

# PVC electronic cables - C-track compatible - Shielded

## LÜTZE SUPERFLEX® TRONIC (C) PUR TP Shielded electronic cable UL recognized, paired For highest requirements



### Application

- Robots, drag chains as well as everywhere where signals are transmitted to continuously moving system or machine parts
- Machine and device construction, transport and conveyor technology, heating, climate technology
- In dry and damp rooms
- As monitoring, measurement and control cable for continuous flexing applications
- Especially for industrial environments with high EMI potential in machine, plant and device construction

### Properties

- High active and passive interference resistance (EMC)
- High crosstalk attenuation due to twisted pairs
- Braided shield optimised for continuous flexing applications
- Low capacitance, very good electrical properties
- Flame-retardant, self-extinguishing
- Halogen-free, no corrosive gases
- Very good alternating bending strength
- Low adhesion, abrasion-resistant, nick-resistant, tear resistant
- Hydrolysis-resistant, microbe-resistant, and rot-resistant
- Good ruggedness and salt water resistance
- Excellent coolant and lubricant resistance
- Resistant to most oils, greases, alcohol-free benzines and kerosene
- Silicone free
- RoHS-compliant

### Technical data

UL approval	AWM 20233
Nominal voltage	300 V 80 °C
Test voltage	3000 V
Insulation resistance	min. 1000 MΩ × km
Temperature range	
moving	-25 °C to +80 °C
fixed	-40 °C to +80 °C
Minimum bending radius	
moving	D × 12
fixed	D × 6
Burning behavior	Flame-retardant according to VDE 0482 Part 265-2, DIN EN 50265-2, IEC 60332-1, UL 1581 Cable Flame, FT1
Halogen free	according to EN 50267-2-1

### Construction

- Bare copper wire, super finely stranded according to DIN VDE 0295 class 6, IEC 60228 class 6
- Conductor insulation Special-TPE
- Conductors color-coded according to DIN 47100
- Zero-potential paired stranding, layer pitch optimised
- Fleece wrap over cable core
- Braid from tinned copper wire, optical coverage ≥ 85 %
- Jacket special-PUR, matte, adhesion-free surface
- Jacket color grey RAL 7001

Part-No.	Number of conductors/cross-section	Outer Ø ca. mm	Weight kg/100 m	Cu-Index kg/100 m
<b>0.25 mm<sup>2</sup></b>				
117170	(2×2×0.25)	6.2	4.4	2.2
117171	(3×2×0.25)	6.5	5.0	2.8
117172	(4×2×0.25)	6.8	5.7	3.4
117173	(5×2×0.25)	7.7	7.3	4.0
117177	(6×2×0.25)	8.1	8.0	4.7
117174	(8×2×0.25)	9.4	11.3	6.0
117175	(10×2×0.25)	10.5	12.4	7.9
117176	(12×2×0.25)	10.8	14.1	9.1
<b>0.34 mm<sup>2</sup></b>				
117180	(2×2×0.34)	6.5	4.7	2.6
117181	(3×2×0.34)	6.8	5.8	3.4
117182	(4×2×0.34)	7.4	7.0	4.2
117183	(5×2×0.34)	8.0	8.2	5.1
117184	(6×2×0.34)	8.6	9.6	5.9
117185	(8×2×0.34)	10.0	13.0	8.3
117186	(10×2×0.34)	10.9	14.9	10.0
117187	(12×2×0.34)	11.2	16.8	11.4
<b>0.5 mm<sup>2</sup></b>				
117190	(2×2×0.5)	7.1	5.9	3.4
117191	(3×2×0.5)	7.5	7.1	4.5
117303	(4×2×0.5)	8.2	8.8	5.7
117192	(5×2×0.5)	9.0	10.4	6.8
117193	(6×2×0.5)	9.9	13.6	8.0
117194	(8×2×0.5)	11.2	17.0	11.2
117195	(10×2×0.5)	12.2	19.3	13.5
117196	(12×2×0.5)	12.6	22.3	15.6
<b>0.75 mm<sup>2</sup></b>				
117199	(2×2×0.75)	8.3	8.3	4.7
117201	(3×2×0.75)	8.8	9.9	6.3
117202	(4×2×0.75)	9.7	12.8	8.2
117203	(5×2×0.75)	10.6	14.6	10.5
117204	(6×2×0.75)	11.5	18.1	12.3
117205	(8×2×0.75)	13.4	23.9	17.6

CE These products are in conformity with the EU Low Voltage Directive 2006/95/EC

### 3. Actuator sensor cables



### 3. Actuator sensor cables

	Jacket	Shielding	Approval	Application	
LÜTZE SUPERFLEX® TRONIC AS PUR	PUR		CE, UL	Actuator sensor wiring Continuous flexing applications such as c-tracks	3.3
LÜTZE SUPERFLEX® TRONIC AS (C) PUR	PUR	•	CE UL	Actuator sensor wiring Continuous flexing applications such as c-tracks	3.4

# PUR actuator-sensor cables - c-track suitable

## LÜTZE SUPERFLEX® TRONIC AS PUR, unshielded For highest requirements



### Application

- Connecting cable for the actuator-sensor technology
- For continuous flexible use e.g. in c-tracks or free movement in the automation technology, transport and conveyor technology, machine tool manufacture
- PUR jacket optimally suited for rough operating conditions and aggressive coolants and lubricants

### Properties

- Very good alternating bending strength
- Good pressure and roll-over resistance
- Low adhesion, abrasion-resistant, nick-resistant, tear resistant
- Hydrolysis-resistant, microbe-resistant, and rot-resistant
- Weatherproof, ozone and UV resistant (normal lighting conditions)
- Good ruggedness and salt water resistance
- Excellent coolant and lubricant resistance
- Resistant to most oils, greases, alcohol-free benzines and kerosene
- Silicone free
- Halogen free
- RoHS-compliant

### Technical data

UL approval	AWM 20549
Nominal voltage	300 V 80 °C
Test voltage	3000 V
Insulation resistance	min. 100 MΩ × km
Temperature range	
moving	-20 °C to +80 °C
fixed	-40 °C to +80 °C
Minimum bending radius	
moving	D × 8
fixed	D × 4
Burning behavior	Flame retardant according to DIN EN 60332-2-2, UL Horizontal Flame-Test, CSA FT 2
Halogen free	according to EN 50267-2-1

### Construction

- Bare copper wire, super finely stranded according to DIN VDE 0295 class 6, IEC 60228 class 6
- Conductor insulation Special-TPE
- Conductors color-coded based on EN 60947-5-2
- Conductors cabled in layers without mechanical stress, layer pitch optimised
- Jacket special-PUR, matte, adhesion-free surface
- Jacket color black RAL 9005

Part-No.	Number of strands/cross-section/ strand colors	Outer Ø ca. mm	Weight kg/100 m	Cu-Index kg/100 m
<b>0.25 mm<sup>2</sup></b>				
117240	3×0.25 brown, blue, black	4.0	1.9	0.8
117241	4×0.25 white, brown, blue, black	4.3	2.3	1.0
117242	8×0.25 white, brown, green, yellow, grey, pink, blue, red	5.9	4.1	2.1
<b>0.34 mm<sup>2</sup></b>				
117243	3×0.34 brown, blue, black	4.2	2.2	1.0
117244	4×0.34 white, brown, blue, black	4.5	2.7	1.3
117245	5×0.34 brown, white, blue, black, grey	4.9	3.2	1.7
117246	5×0.34 brown, white, blue, black, greenyellow	4.9	3.2	1.7
<b>Actuator-sensor connecting cables</b>				
110872	3G1.0+8×0.34 1.0: brown, blue, greenyellow 0.34: white, black, green, yellow, grey, pink, violet, red	8.2	9.9	5.5
110874	3G1.0+16×0.34 1.0: brown, blue, greenyellow 0.34: white, green, yellow, grey, pink, red, black, violet, greypink, redblue, whitegreen, brownngreen, whiteyellow, yellowbrown, whitegrey, greybrown	9.7	13.5	8.1

CE These products are in conformity with the EU Low Voltage Directive 2006/95/EC

# PUR actuator-sensor cables - C-track suitable

## LÜTZE SUPERFLEX® TRONIC AS (C) PUR, shielded For highest requirements



### Application

- Connecting cable for the actuator-sensor technology
- For continuous flexible use e.g. in c-tracks or free movement in the automation technology, transport and conveyor technology, machine tool manufacture
- PUR jacket optimally suited for rough operating conditions and aggressive coolants and lubricants

### Properties

- Very good alternating bending strength
- High active and passive interference resistance (EMC)
- Good pressure and roll-over resistance
- Low adhesion, abrasion-resistant, nick-resistant, tear-propagation-resistant
- Hydrolysis-resistant, microbe-resistant, and rot-resistant
- Weatherproof, ozone and UV resistant (normal lighting conditions)
- Good resistance to use and salt water
- Excellent coolant and lubricant resistance
- Resistant to most oils, greases, alcohol-free benzines and kerosene
- Silicone free
- Halogen free
- RoHS compliant

### Technical data

UL approval	AWM 20549
Nominal voltage	300 V 80 °C
Test voltage	3000 V
Insulation resistance	min. 100 MΩ × km
Temperature range	
moving	-20 °C to +80 °C
fixed	-40 °C to +80 °C
Minimum bending radius	
moving	D × 12
fixed	D × 6
Burning behavior	Flame retardant according to DIN EN 60332-2-2, UL Horizontal Flame-Test, CSA FT 2
Halogen free	according to EN 50267-2-1

### Construction

- Bare copper wire, super finely stranded according to DIN VDE 0295 class 6, IEC 60228 class 6
- Conductor insulation Special-TPE
- Conductors color-coded based on EN 60947-5-2
- Conductors cabled in layers without mechanical stress, layer pitch optimised
- Fleece wrap over cable core
- Braid from tinned copper wire, optical coverage ≥ 85 %
- Jacket special-PUR, matte, adhesion-free surface
- Jacket color black RAL 9005

Part-No.	Number of strands/cross-section/ strand colors	Outer Ø ca. mm	Weight kg/100 m	Cu-Index kg/100 m
<b>0.25 mm<sup>2</sup></b>				
117250	(3×0.25) brown, blue, black	4.6	2.8	1.7
117251	(4×0.25) white, brown, blue, black	4.9	3.3	2.0
117252	(8×0.25) white, brown, green, yellow, grey, pink, blue, red	6.3	5.5	3.5
<b>0.34 mm<sup>2</sup></b>				
117253	(3×0.34) brown, blue, black	4.8	3.2	2.0
117254	(4×0.34) white, brown, blue, black	5.1	3.8	2.4
117255	(5×0.34) brown, white, blue, black, grey	5.5	4.5	2.8

CE These products are in conformity with the EU Low Voltage Directive 2006/95/EC



## 4. Bus and network cables



## 4. Bus and network cables

	Jacket	Shielding	Approval	Application	
<b>LÜTZE ELECTRONIC ASI BUS TPE</b>	TPE		CE	For Stationary and Flexible Applications within Machine- and Plant Wiring According to ASI BUS standard	4.3
<b>LÜTZE ELECTRONIC Profibus (C) PVC</b>	PVC	•	CE	For Stationary and Flexible Applications within Machine- and Plant Wiring According to Profibus standard	4.4
<b>LÜTZE ELECTRONIC Profibus (C) PVC</b>	PVC	•	CE	For Stationary and Flexible Applications within Machine- and Plant Wiring According to Profibus standard	4.5
<b>LÜTZE SUPERFLEX® Profibus (C) PUR</b>	PUR	•	CE, UL	Continuous Moving in Drag Chains According to Profibus standard with international approvals For highest requirements	4.6
<b>LÜTZE ELECTRONIC CAN-BUS (C) PVC</b>	PVC	•	CE, UL	For Stationary and Flexible Applications within Machine- and Plant Wiring According to CAN-BUS standard with international approvals	4.7
<b>LÜTZE SUPERFLEX® CAN-BUS (C) PUR</b>	PUR		CE, UL	Continuous Moving in Drag Chains According to CAN-BUS standard with international approvals For extremely harsh operating conditions	4.8
<b>LÜTZE ELECTRONIC INTERBUS (C) PVC</b>	PVC	•	CE, UL	For Stationary and Flexible Applications within Machine- and Plant Wiring According to INTERBUS standard with International approvals	4.9
<b>LÜTZE SUPERFLEX® INTERBUS (C) PUR</b>	PUR	•	CE, UL	Continuous Moving in Drag Chains According to INTERBUS standard with international approvals For extremely harsh operating conditions	4.10
<b>LÜTZE ELECTRONIC DeviceNet™ (C) PVC</b>	PVC	•	CE, UL	For Stationary and Flexible Applications within Machine- and Plant Wiring According to DeviceNet™ standard with International approvals	4.11
<b>LÜTZE SUPERFLEX® DeviceNet™ (C) PUR</b>	PUR	•	CE, UL	Continuous Moving in Drag Chains According to DeviceNet™ standard with international approvals For extremely harsh operating conditions	4.12
<b>LÜTZE ELECTRONIC ETHERNET (C) PVC</b>	PVC	•	CE, UL, AWM	For Stationary and Flexible Applications within Machine- and Plant Wiring Industrial Ethernet/Profinet/EtherCat Industrial Ethernet/Ethernet IP Cat 5e, Cat 6a, Cat 7	4.13
<b>LÜTZE SUPERFLEX® ETHERNET (C) PUR</b>	PUR	•	CE, UL, AWM	Continuous Moving in Drag Chains Industrial Ethernet/Profinet/EtherCat Industrial Ethernet/Ethernet IP Cat 5e, Cat 6 For extremely harsh operating conditions	4.14

\* Registered Trade Marks

# Bus cables - ASI BUS

## LÜTZE ELECTRONIC ASI BUS TPE



### Application

- System cables for connection of actuator interface components
- Application in the automation technology, in tool and machine construction, plants and device construction, transport and conveyor technology

### Properties

- Inverse polarity-proof flat cable
- Fast contacting due to penetration technology
- TPE construction especially suitable in areas in which oils, greases and cooling lubricants occur
- Silicone free
- RoHS-compliant

### Technical data

Rated voltage	300 V
Test voltage	2000 V
Temperature range	
moving	-15 °C to +80 °C
fixed	-30 °C to +80 °C
Minimum bending radius	
moving	D × 12
fixed	D × 6
Loop resistance	27.4 mΩ/m

### Construction

- Tinned copper wire
- Braid 1.5 mm<sup>2</sup> according to VDE 0295 Class 6
- Conductor insulation PVC
- Jacket TPE profiled
- Jacket color  
black RAL 9005: for auxiliary energy 30 V<sub>DC</sub>  
yellow RAL 1021: data and energy transfer

Part-No.	Number of strands/cross-section/ strand colors	Weight kg/100 m	Cu-Index kg/100 m	Jacket
<b>1.5 mm<sup>2</sup></b>				
104216	2×1.5 blue, brown	6.2	2.8	yellow
104217	2×1.5 blue, brown	6.2	2.8	black

CE These products are in conformity with the EU Low Voltage Directive 2006/95/EC

# Bus cables - Profibus

## LÜTZE ELECTRONIC Profibus (C) PVC



### Application

- For the cabling of industrial field bus systems like PROFIBUS DP, F.I.P.
- With solid conductor AWG22/1 for fixed wiring or with stranded conductor for moving applications without continuous flexing in the automation technology, transport and conveyor technology, machine tool manufacture

### Properties

- High active and passive interference resistance (EMC)
- Silicone free
- RoHS-compliant

### Technical data

Rated voltage	250 V
Test voltage	1500 V
Impedance	AWG 22: nom. 150 Ω 1.0 mm <sup>2</sup> : nom. 100 Ω
Loop resistance	AWG 22: <110 Ω/km 1.0 mm <sup>2</sup> : 39 Ω/km
Operating capacitance	AWG 22: nom. 30 pF/m 1.0 mm <sup>2</sup> : nom. 52 pF/m
Temperature range	
moving	-5 °C to +70 °C
fixed	-30 °C to +80 °C
Minimum bending radius	
moving	D × 12
fixed	D × 6
Burning behavior	Flame-retardant according to VDE 0482 part 265-2, HM version: halogen free, low smoke

### Construction

- Bare copper wire
- Wire according to AWG or DIN
- Conductor insulation special polyolefin
- ST Static foil shield
- Braid from tinned copper wire, optical coverage ≥ 70 %
- PVC jacket or HM version with special thermoplastic
- Jacket color violet RAL 4001, blue RAL 5015, black RAL 9005 (see item description)

Part-No.	Number of strands/cross-section/ strand colors	Jacket color	Outer Ø ca. mm	Weight kg/100 m	Cu-Index kg/100 m
<b>Profibus DP/FMS/FIP</b>					
104214	(1×2×AWG22/7)StC red/green	violet RAL 4001	7.8	6.8	3.0
<b>Profibus DP/FMS/FIP with inner jacket, halogen-free jacket (HM)</b>					
104267	(1×2×AWG22/1)StC FC red/green	violet RAL 4001	7.8	7.7	3.0
<b>Profibus PA</b>					
104277	(1×2×AWG18/1) red/green	blue RAL 5015	8.0	8.4	4.5
104278	(1×2×AWG18/1) red/green	black RAL 9005	8.0	8.4	4.5

CE These products are in conformity with the EU Low Voltage Directive 2006/95/EC

# PVC Bus cables - Profibus

## LÜTZE ELECTRONIC Profibus (C) PVC



### Application

- For the cabling of industrial field bus systems like PROFIBUS DP, F.I.P.
- With solid conductor AWG22/1 for hard wiring or with 7-wire stranded conductor for moving use without continuous flexing in the automation technology, transport and conveyor technology, machine tool manufacture

### Properties

- High active and passive interference resistance (EMC)
- Silicone free
- RoHS-compliant

### Technical data

Rated voltage	300 V
Test voltage	1500 V
Impedance	nom. 150 Ω
Loop resistance	
Solid 22/1	<110 Ω/km
Flexible 24/7	<165 Ω/km
Operating capacitance	nom. 30 pF/m
Temperature range	
moving	-10 °C to +70 °C
fixed	-40 °C to +80 °C
Minimum bending radius	
moving	D × 15
fixed	D × 7.5
Burning behavior	CMX: FT1 UL 1581, IEC 60332-3-24 CMG: FT4 UL 1685, CSA UL, IEC 60332-1
Approvals	cULus

### Construction

- Bare copper wire
- Wire according to AWG
- Conductor insulation Special polyolefin
- Inner jacket for versions with fast assembly FC
- ST static shield
- Braid shield from tinned copper, optical coverage ca. 70 %.
- Jacket special-PVC
- Jacket color violet RAL 4001

Part-No.	Number of strands/cross-section/ strand colors	Outer Ø ca. mm	Weight kg/100 m	Cu-Index kg/100 m
<b>Profibus DP/FMS/FIP, single wire UL/CMX, AWM 20601 300 V</b>				
104378	(1×2×AWG22/1) red/green	8.0	5.8	3.0
<b>Profibus DP/FMS/FIP, Flexible UL/CMG 75 °C, AWM 21694 600 V</b>				
104344	(1×2×AWG24/7) red/green	8.0	7.2	3.0
<b>Profibus DP/FMS/FIP, Fast Connection FC UL/CMG, AWM 20201 600 V</b>				
104293	(1×2×AWG22/1) red/green	7.8	7.4	3.0

CE These products are in conformity with the EU Low Voltage Directive 2006/95/EC

# PUR Bus cables - Profibus - C-track compatible

## LÜTZE SUPERFLEX® Profibus (C) PUR For highest requirements



### Application

- For the cabling of industrial field bus systems like PROFIBUS DP, SINEC L2, F.I.P.
- For continuous flexible use e.g. in c-tracks or free movement in automation technology, transport and conveyor technology, machine tool manufacture

### Properties

- High active and passive interference resistance (EMC)
- Silicone free
- Halogen free
- RoHS-compliant

### Technical data

Rated voltage	300 V
Test voltage	1500 V
Impedance	nom. 150 Ω
Loop resistance	<165 Ω/km
Operating capacitance	<30 pF/m
Temperature range	
moving	-30 °C to +70 °C
fixed	-40 °C to +80 °C
Minimum bending radius	
moving	D × 7.5
fixed	D × 5
moves quick assembly FC	D × 15
fixed	D × 7.5
Burning behavior	VW-1, FT 1 UL 1581, IEC 60332-1
Halogen free	according to EN 50267-2-1
Approvals	cULus CMX, UL AWM 21198 300 V 80 °C

### Construction

- Bare copper wire
- Wire according to AWG  
Wire AWG 24/19 = 0.64 mm Ø
- Conductor insulation special polyolefin
- Inner jacket versions with fast assembly FC
- ST foil shield
- Braid shield from tinned copper, optical coverage approx. ≥ 85 %, at FC 70 %
- Jacket special-PUR, matte, adhesion-free surface
- Jacket color violet, RAL 4001

Part-No.	Number of strands/cross-section/ strand colors	Outer Ø ca. mm	Weight kg/100 m	Cu-Index kg/100 m
<b>Profibus, high flexing UL/CMX</b>				
104265	(1×2×AWG24/19) red/green	8.0	6.5	3.0
<b>Profibus Fast Connection FC UL/CMX</b>				
104287	(1×2×AWG24/19) red/green	8.0	8.0	3.0
<b>Profibus ET200 UL AWM 21198</b>				
104275	((1×2×AWG24/19)St+3G0.75)C red/green, blue/black/greenyellow	9.8	14.4	6.6

CE These products are in conformity with the EU Low Voltage Directive 2006/95/EC

# PVC Bus cables - CAN-BUS

## LÜTZE ELECTRONIC CAN-BUS (C) PVC



CANopen



### Application

- For wiring of industrial field bus systems like CAN-BUS
- For fixed wiring or moving applications without continuous flexing in the automation technology, transport and conveyor technology, machine tool manufacture

### Properties

- High active and passive interference resistance (EMC)
- Silicone free
- RoHS-compliant

### Technical data

Rated voltage	300 V
Test voltage	1500 V
Impedance	nom. 120 Ω
Loop resistance	
AWG 24/7	<175.2 Ω/km
AWG 22/7	<110.8 Ω/km
Operating capacitance	<60 pF/m
Temperature range	
moving	-10 °C to +70 °C
fixed	-40 °C to +75 °C
Minimum bending radius	
moving	D × 15
fixed	D × 7.5
Burning behavior	Flame-retardant according to VDE 0482 part 265-2; IEC 60332-1
Approvals	cULus CMX

### Construction

- Bare copper wire
- Wire according to AWG or DIN
- Conductor insulation Special polyolefin
- Conductors stranded pairs, foil tape
- Braid from tinned copper wire, optical coverage ≥ 85 %
- Jacket special PVC TM2 according to VDE 0281-1, matte, adhesion-free surface
- Jacket color violet, RAL 4001

Part-No.	Number of strands/cross-section/ strand colors	Outer Ø ca. mm	Weight kg/100 m	Cu-Index kg/100 m
<b>CAN-BUS UL/CMX, 40 m max.</b>				
104386	(1×2×AWG24/7) white/brown	5.4	4.3	2.0
104387	(2×2×AWG24/7) white/brown, green/yellow	7.5	6.8	3.5
<b>CAN-BUS UL/CMX, 200 m max.</b>				
104388	(1×2×AWG22/7) white/brown	6.1	5.8	2.6
104389	(2×2×AWG22/7) white/brown, green/yellow	8.8	8.6	4.6

CE These products are in conformity with the EU Low Voltage Directive 2006/95/EC

# PUR Bus cables - CAN-BUS - C-track compatible

## LÜTZE SUPERFLEX® CAN-BUS (C) PUR For highest requirements



CANopen



### Application

- For wiring of industrial field bus systems like CAN-BUS
- for continuous flexible use e.g. in c-tracks or free movement in the automation technology, transport and conveyor technology, machine tool manufacture

### Properties

- High active and passive interference resistance (EMC)
- Silicone free
- Halogen free
- RoHS-compliant

### Technical data

Rated voltage	300 V
Test voltage	3000 V
Impedance	nom. 120 Ω
Operating capacitance	<60 pF/m
Temperature range	
moving	-30 °C to +70 °C
fixed	-40 °C to +75 °C
Minimum bending radius	
moving	D × 15
fixed	D × 7.5
Burning behavior	Flame-retardant according to VDE 0482 part 265-2; IEC 60332-1 UL 1581 section VW-1 Flame-Test, CSA FT 1
Halogen free	according to EN 50267-2-1
Approvals	cULus CMX

Part-No.	Number of strands/cross-section/ strand colors	Outer Ø ca. mm	Weight kg/100 m	Cu-Index kg/100 m
<b>CAN-BUS UL/CMX, 40 m max.</b>				
104390	(1×2×AWG24) white/brown	5.4	4.4	2.4
104391	(2×2×AWG24) white/brown, green/yellow	7.2	7.2	3.3

### Construction

- Bare copper wire
- Conductor insulation Special polyolefin
- Stranded pair conductors or star quad, foil tape
- Braid from tinned copper wire, optical coverage ≥ 85 %
- Jacket special-PUR, matte, adhesion-free surface
- Jacket color violet RAL 4001

CE These products are in conformity with the EU Low Voltage Directive 2006/95/EC



# PVC Bus cables - INTERBUS

## LÜTZE ELECTRONIC INTERBUS (C) PVC



### Application

- For wiring of industrial field bus systems such as Interbus
- For fixed installation or moving use without continuous flexing in the automation technology, transport and conveyor technology, machine tool manufacture

### Properties

- High active and passive interference resistance (EMC)
- Silicone free
- RoHS-compliant

### Technical data

UL approval	AWM 21500
Nominal voltage	300 V 60 °C
Test voltage	1500 V
Impedance	nom. 100 Ω
Loop resistance	<165 Ω/km
Operating capacitance	<60 pF/m
Temperature range	
moving	-10 °C to +70 °C
fixed	-40 °C to +80 °C
Minimum bending radius	
moving	D × 15
fixed	D × 7.5
Burning behavior	Flame-retardant according to VDE 0482 part 265-2; IEC 60332-1 UL Horizontal Flame

### Construction

- Bare copper wire
- Wire according to AWG or DIN
- Conductor insulation Special polyolefin
- Conductors stranded pairs, foil tape
- Braid from tinned copper wire, optical coverage ≥ 85 %
- Jacket special PVC TM2 according to VDE 0281-1, matte, adhesion-free surface
- Jacket color violet RAL 4001

Part-No.	Number of strands/cross-section/ strand colors	Outer Ø ca. mm	Weight kg/100 m	Cu-Index kg/100 m
104207	(3×2×0.22) white/brown, green/yellow, grey/pink	7.5	5.5	3.2

CE These products are in conformity with the EU Low Voltage Directive 2006/95/EC

# PUR bus cables - INTERBUS - C-track compatible

## LÜTZE SUPERFLEX® INTERBUS (C) PUR



### Application

- For wiring of industrial field bus systems such as Interbus
- For continuous flexible use e.g. in c-tracks or free movement in the automation technology, transport and conveyor technology, machine tool manufacture

### Properties

- High active and passive interference resistance (EMC)
- Silicone free
- Halogen free
- RoHS-compliant

### Technical data

UL approval	AWM 20549
Nominal voltage	300 V 80 °C
Test voltage	3000 V
Impedance	nom. 100 Ω
Loop resistance	<155 Ω/km
Operating capacitance	<60 pF/m
Temperature range	
moving	-20 °C to +80 °C
fixed	-40 °C to +80 °C
Minimum bending radius	
moving	D × 12
fixed	D × 6
Burning behavior	Flame-retardant according to VDE 0482 part 265-2; IEC 60332-1 UL 1581 section VW-1 Flame-Test, CSA FT 1
Halogen free	according to EN 50267-2-1

### Construction

- Bare copper wire
- Wire according to AWG or DIN
- Conductor insulation Special polyolefin
- Conductors stranded pairs, foil tape
- Braid from tinned copper wire, optical coverage ≥ 85 %
- Jacket special-PUR, matte, adhesion-free surface
- Jacket color violet RAL 4001

Part-No.	Number of strands/cross-section/ strand colors	Outer Ø ca. mm	Weight kg/100 m	Cu-Index kg/100 m
104258	(3×2×0.24) white/brown; green/yellow; grey/pink	7.7	6.5	2.9
104259	(3G1.0+3×2×0.24) white/brown; green/yellow; grey/pink	8.5	9.9	6.5

CE These products are in conformity with the EU Low Voltage Directive 2006/95/EC

# PVC bus cables - DeviceNet™

## LÜTZE ELECTRONIC DeviceNet™ (C) PVC



### Application

- For the wiring of industrial devices, sensors, control devices (SPS), valves
- DeviceNet™ is the leading BUS system for industry automation in the USA
- For fixed wiring or moving applications without continuous flexing in the automation technology, transport and conveyor technology, machine tool manufacture

### Properties

- High active and passive interference resistance (EMC)
- Silicone free
- RoHS compliant

### Technical data

Rated voltage	300 V
Test voltage	2000 V
Impedance	nom. 120 Ω
Loop resistance	
AWG 16	<22.6 Ω/km
AWG 18	<54.4 Ω/km
AWG 22	<114.8 Ω/km
AWG 24	<181.8 Ω/km
Operating capacitance	<40 pF/m
Temperature range	
moving	-10 °C to +75 °C
fixed	-40 °C to +75 °C
Minimum bending radius	
moving	D × 10
fixed	D × 5
Burning behavior	Flame-retardant according to VDE 0482 part 265-2, IEC 60332-3-24 UL 1581 section VW-1 Flame-Test, CSA FT 4
Approvals	cULus CMG UL AWM 20201 600 V 60 °C

### Construction

- Tinned copper wire
- Conductor insulation Special polyolefin (BUS element)
- Overall shield: Braid from galvanised Cu wire, optical coverage ≥ 70 %
- Jacket special-PVC, matte, adhesion-free surface
- Jacket color violet RAL 4001

Part-No.	Number of strands/cross-section/ strand colors	Outer Ø ca. mm	Weight kg/100 m	Cu-Index kg/100 m
<b>DeviceNet™ Thick UL/CMG, PLTC</b>				
104288	((2xAWG18)+(2xAWG16)) white/blue, red/black	12.2	20.1	8.8
<b>DeviceNet™ Thin UL/CMG/CL2</b>				
104282	((2xAWG24)+(2xAWG22)) white/blue, red/black	7.0	6.6	3.2

CE These products are in conformity with the EU Low Voltage Directive 2006/95/EC

# PUR Bus cables - DeviceNet™ - C-track compatible

## LÜTZE SUPERFLEX® DeviceNet™ (C) PUR For highest requirements



### Application

- For the wiring of industrial devices, sensors, control devices (SPS), valves
- DeviceNet™ is the leading BUS system for industry automation in the USA
- For continuous flexible use e.g. in c-tracks or free movement in the automation technology, transport and conveyor technology, machine tool manufacture

### Properties

- High active and passive interference resistance (EMC)
- Silicone free
- RoHS compliant

### Technical data

Impedance	nom. 120 Ω
Operating capacitance	<40 pF/m
Rated voltage	300 V
Test voltage	3000 V
Temperature range	
moving	-20 °C to +80 °C
fixed	-40 °C to +75 °C
Minimum bending radius	
moving	D × 10
fixed	D × 5
Burning behavior	Flame-retardant according to VDE 0482 part 265-2; IEC 60332-1; UL 1581 section VW-1 Flame-Test; CSA FT 1
Halogen free	according to EN 50267-2-1, EN 60684-2
Approvals	cULus CMX

### Construction

- Tinned copper wire
- Special polyolefin (BUS element)
- BUS element statically shielded
- Total shield: Braid from galvanised Cu wire, optical coverage ≥ 85 %
- Jacket special-PUR, matte, adhesion-free surface
- Jacket color violet RAL 4001

Part-No.	Number of strands/cross-section/ strand colors	Outer Ø ca. mm	Weight kg/100 m	Cu-Index kg/100 m
<b>DeviceNet™ Thick UL/CMX</b>				
104279	((2×AWG18)+(2×AWG16)) white/blue, red/black	11.3	18.0	2.1
<b>DeviceNet™ Thin UL/CMX</b>				
104289	((2×AWG24)+(2×AWG22)) white/blue, red/black	7.3	8.5	2.8

CE These products are in conformity with the EU Low Voltage Directive 2006/95/EC

# PVC Bus cables - ETHERNET

## LÜTZE ELECTRONIC ETHERNET (C) PVC



### Application

- For the cabling of industrial field bus systems with the globally accepted TCP/IP protocol
- For fixed installation or mobile use without continuous flexing in automation technology, transport, conveyor technology and machine tools

### Properties

- High active and passive interference resistance (EMC)
- Silicone free
- RoHS-compliant

### Technical data

Rated voltage	300 V
Test voltage	1500 V
Impedance	nom. 100 Ω
Loop resistance	
Wire AWG 22/1= 0.34 <sup>2</sup>	<110 Ω/km
Wire AWG 24/7= 0.22 <sup>2</sup>	<165 Ω/km
Wire AWG 26/7=0.14 <sup>2</sup>	<273 Ω/km
Operating capacitance	<50 pF/m
Temperature range	
moving	-5 °C to +70 °C
run	-30 °C to +80 °C
Minimum bending radius	
moving	D × 12
fixed	D × 6
Burning behavior	Flame-retardant according to VDE 0482 part 265-2; IEC 60332-1 UL 1581 section VW-1 Flame-Test, CSA FT 4
Approvals	cULus CMG cULus PLTC cURus AWM

### Construction

- Bare copper wire
- Wire according to AWG
- Conductor insulation Special polyolefin
- ST static shield
- Braid from tinned copper wire, optical coverage ≥ 85 %
- Jacket PVC, matte, adhesion-free surface
- Jacket color green RAL 6018

Part-No.	Number of strands/cross-section/ strand colors	Outer Ø ca. mm	Weight kg/100 m	Cu-Index kg/100 m
<b>ELECTRONIC Industrial Ethernet/Profinet/EtherCat</b>				
104301	(2x2xAWG22/1)StC CMG, PLTC, AWM 20201 600 V Cat5 100 MHz, SF/UTQ Star quad, FC, ProfiNet type A Transmission pair white/blue, yellow/ orange	6.5	6.5	3.7
104307	(2x2xAWG22/7)StC CMG, PLTC, AWM 20201 600 V Cat5 100 MHz, SF/UTQ Star quad, FC, ProfiNet type B Transmission pair white/blue, yellow/ orange	6.5	6.5	3.1
104397	(4x(2xAWG22/1)St)C CMG, PLTC, AWM 2570 600 V Cat6a 600 MHz, S/FTP whiteblue/blue, whiteorange/orange, whitegreen/green, whitebrown/brown	9.6	9.6	5.3
<b>ELECTRONIC Industrial Ethernet/Ethernet IP</b>				
104335	(4x2xAWG26/7 St)C CMG Cat5e 100 MHz, SF/UTP whiteblue/blue, whiteorange/orange, whitegreen/green, whitebrown/brown	6.3	5.5	3.0
104336	(4x2xAWG24/7 St)C CMG Cat5e 100 MHz, SF/UTP whiteblue/blue, whiteorange/orange, whitegreen/green, whitebrown/brown	7.3	6.9	3.8
104338	(4x(2xAWG26/7)St)C CMG Cat6a 500 MHz, S/FTP whiteblue/blue, whiteorange/orange, whitegreen/green, whitebrown/brown	6.4	5.3	3.3
104331	(4x(2xAWG26/7)St)C CMG Cat7 600 MHz, S/FTP whiteblue/blue, whiteorange/orange, whitegreen/green, whitebrown/brown	7.0	6.2	3.3

CE These products are in conformity with the EU Low Voltage Directive 2006/95/EC

# PUR Bus cables - ETHERNET - C-track compatible

## LÜTZE SUPERFLEX® ETHERNET (C) PUR For highest requirements



### Application

- For the cabling of industrial field bus systems with the globally accepted TCP/IP protocol
- For fixed installation or mobile use without continuous flexing in automation technology, transport, conveyor technology and machine tools

### Properties

- High active and passive interference resistance (EMC)
- Silicone free
- Halogen free
- RoHS-compliant

### Technical data

Rated voltage	250 V
Test voltage	1500 V
Impedance	nom. 100 Ω
Loop resistance	
AWG 22/7= 0.34 <sup>2</sup>	<110 Ω/km
AWG 22/19= 0.34 <sup>2</sup>	<110 Ω/km
AWG 24/19= 0.24 <sup>2</sup>	<159,5 Ω/km
AWG 26/19= 0.14 <sup>2</sup>	<280 Ω/km
Operating capacitance	<50 pF/m
Temperature range	
moving	-30 °C to +70 °C
fixed	-40 °C to +80 °C
Minimum bending radius	
moving	D × 12
fixed	D × 6
Burning behavior	Flame-retardant according to VDE 0482 part 265-2; IEC 60332-1, UL 1581 section VW-1 Flame-Test, CSA FT 1
Halogen free	according to EN 50267-2-1
Approvals	cULus CMX cURus AWM

Part-No.	Number of strands/cross-section/ strand colors	Outer Ø ca. mm	Weight kg/100 m	Cu-Index kg/100 m
<b>SUPERFLEX Industrial Ethernet/ProfiNet/Ethercat</b>				
104302	(2×2×AWG22/19)StC CMX Cat5 100 MHz, SF/UTQ Star quad Transmission pair white/blue, yellow/ orange	6.6	7.5	3.7
104303	(2×2×AWG22/7)StC CMX Cat5 100 MHz, SF/UTQ Star quad, Profinet type C Transmission pair white/blue, yellow/ orange	6.5	6.1	3.1
<b>SUPERFLEX Industrial Ethernet/Ethernet IP</b>				
104379	(2×2×AWG26/19) AWM 21198 Cat5e 100 MHz, SF/UTQ white, blue, yellow, orange	5.3	3.5	1.8
104337	(4×2×AWG24/19) AWM 21198 Cat5e 100 MHz, S/UTP whiteblue/blue, whiteorange/orange, whitegreen/green, whitebrown/brown	7.8	6.8	5.5
104396	(4×2×AWG26/19) AWM 21198 Cat5e 100 MHz, SF/UTP whiteblue/blue, whiteorange/orange, whitegreen/green, whitebrown/brown	6.7	5.4	2.8
104347	(4×2×AWG26/19) CMX Cat6 350 MHz, SF/UTP whiteblue/blue, whiteorange/orange, whitegreen/green, whitebrown/brown	7.9	6.3	4.2

### Construction

- Bare copper wire
- Wire according to AWG
- Conductor insulation Special polyolefin
- ST static shield
- Halogen-free sub jacket
- Braid from tinned copper wire, optical coverage ≥ 85 %
- Jacket special-PUR, matte, adhesion-free surface
- Jacket color green RAL 6018

CE These products are in conformity with the EU Low Voltage Directive 2006/95/EC

## 5. Motor, Servo and Feedback cables



## 5. Motor, Servo and Feedback cables

	Jacket	Shielding	Approval	Application	
LÜTZE SILFLEX® M PVC 0,6/1 kV	PVC		CE	For Stationary and Flexible Applications within Machine- and Plant Wiring	5.3
LÜTZE SILFLEX® M (C) PVC 0,6/1 kV	PVC	•	CE	For Stationary and Flexible Applications within Machine- and Plant Wiring	5.4
LÜTZE SILFLEX® M XLPE 3 (C) PVC 0,6/1 kV	PVC	•	CE	For Stationary and Flexible Applications within Machine- and Plant Wiring	5.5
LÜTZE-SILFLEX® M (C) PVC UL SERVO 0,6/1 kV	PVC	•	CE, UL	For Stationary and Flexible Applications within Machine- and Plant Wiring with international Approval	5.6
LÜTZE-SILFLEX® (C) PVC FEEDBACK	PVC	•	CE, UL	For Stationary and Flexible Applications within Machine- and Plant Wiring with international Approval	5.7
LÜTZE SUPERFLEX® PLUS M PUR UL 0,6/1 kV	PUR		CE, UL	Continuous Moving in Drag Chains Motor- / Power Supply Cable For highest requirements	5.9
LÜTZE SUPERFLEX® PLUS M (C) PUR UL SERVO 0,6/1 kV	PUR	•	CE, UL	Continuous Moving in Drag Chains Supply line for Siemens* and other systems For highest requirements	5.10
LÜTZE SUPERFLEX® PLUS M (C) PUR SERVO 0,6/1 kV	PUR	•	CE, UL	Continuous Moving in Drag Chains Supply line for Bosch-Rexroth* and other systems For highest requirements	5.11
LÜTZE SUPERFLEX® PLUS M (C) PUR SERVO 0,6/1 kV	PUR	•	CE, UL	Continuous Moving in Drag Chains Supply line for Lenze* and other systems For highest requirements	5.12
LÜTZE SUPERFLEX® PLUS M (C) PUR SERVO 0,6/1 kV	PUR	•	CE, UL	Continuous Moving in Drag Chains Supply line for SEW* and other systems For highest requirements	5.13
LÜTZE SUPERFLEX® PLUS (C) PUR HYBRID SERVO 0,6/1kV	PUR	•	CE, UL	Continuous Moving in Drag Chains Composite Supply Cable for Servo Motors with Hiperface DSL® interface For highest requirements	5.14
LÜTZE SUPERFLEX® PLUS PUR 0,6/1kV	PUR	•	CE, UL	Continuous Moving in Drag Chains Motor- / Power Supply Cable For highest requirements	5.15
LÜTZE SUPERFLEX® PLUS (C) PUR 0,6/1kV	PUR	•	CE, UL	Continuous Moving in Drag Chains Motor- / Power Supply Cable For highest requirements	5.16
LÜTZE SUPERFLEX® PLUS (C) PUR FEEDBACK	PUR	•	CE, UL	Continuous Moving in Drag Chains Feedback cables for Siemens* and other systems For highest requirements in Drive Technology	5.17
LÜTZE SUPERFLEX® PLUS (C) PUR FEEDBACK	PUR	•	CE, UL	Continuous Moving in Drag Chains Feedback cables for Bosch-Rexroth* and other systems For highest requirements in Drive Technology	5.18
LÜTZE SUPERFLEX® PLUS (C) PUR FEEDBACK	PUR	•	CE, UL	Continuous Moving in Drag Chains Feedback cables for Lenze* and other systems For highest requirements in Drive Technology	5.19
LÜTZE SUPERFLEX® PLUS (C) PUR FEEDBACK	PUR	•	CE, UL	Continuous Moving in Drag Chains Feedback cables for SEW* and other systems For highest requirements in Drive Technology	5.20
LÜTZE SUPERFLEX® PLUS (C) PUR FEEDBACK	PUR	•	CE, UL	Continuous Moving in Drag Chains Feedback cables for Allen Bradley* and other systems For highest requirements in Drive Technology	5.21
LÜTZE SUPERFLEX® PLUS (C) PUR FEEDBACK	PUR	•	CE, UL	Continuous Moving in Drag Chains Feedback cables for Heidenhain* and other systems For highest requirements in Drive Technology	5.22
LÜTZE SUPERFLEX® PLUS (C) PUR FEEDBACK	PUR	•	CE, UL	Continuous Moving in Drag Chains Feedback Cables for Various Systems For highest requirements in Drive Technology	5.23

\* Registered Trade Marks



# PVC motor cables - unshielded

## LÜTZE SILFLEX® M PVC 0,6/1 kV Motor/connecting/power supply cable



### Application

- Motor/connecting and power supply cable in machine engineering, transport and conveyor technology, HVAC technology
- In dry and damp rooms
- For flexible application without continuous flexing

### Properties

- PVC Flame-retardant, self-extinguishing
- Resistant to most oils, greases, acids and bases
- Silicone free
- RoHS compliant

### Technical data

#### Voltage

U<sub>0</sub>/U 0.6/1 kV

#### Test voltage

4000 V

#### Insulation resistance

min. 20 MΩ × km

#### Temperature range

moving -5 °C to +70 °C

fixed -25 °C to +70 °C

#### Minimum bending radius

moving D × 10

fixed D × 4

#### Burning behavior

Flame-retardant according to

VDE 0482 part 265-2,

DIN EN 50265-2

IEC 60332-1

### Construction

- Bare copper wire, super finely stranded according to DIN VDE 0295 Kl. 5 or IEC 60228 cl. 5
- Conductor insulation Special PVC
- Conductors black with white number print according to DIN EN 50334
- Ground conductor green/yellow according to DIN EN 50334
- Jacket special PVC TM5 according to VDE 0281-1, matte, adhesion-free surface
- Jacket color black RAL 9005

Part-No.	Number of conductors/cross-section	Outer Ø ca. mm	Weight kg/100 m	Cu-Index kg/100 m
101385	4G1.5	9.8	15.8	5.8
101386	4G2.5	11.4	23.5	9.6
101387	4G4	13.1	35.9	15.4
101388	4G6	14.8	48.6	23.0
101389	4G10	19.0	78.7	38.4
101190	5G10	20.8	88.2	48.0
101390	4G16	22.2	116.1	61.4
101191	5G16	24.8	161.6	76.8
101180	4G25	28.5	162.4	96.0
101192	5G25	31.4	207.5	120.0
101181	4G35	32.0	241.5	134.5
101193	5G35	35.5	289.0	168.0
101182	4G50	36.3	339.0	192.0

CE These products are in conformity with the EU Low Voltage Directive 2006/95/EC

# PVC motor cables - shielded

## LÜTZE SILFLEX® M (C) PVC 0,6/1 kV Shielded motor/connecting/power supply cable



### Application

- Motor/connecting and power supply cable in machine engineering, transport and conveyor technology, HVAC technology
- In dry and damp rooms
- Cables with integrated, shielded measurement circuit cable for motor protector devices
- For flexible application without continuous flexing

### Properties

- High active and passive interference resistance (EMC)
- PVC Flame-retardant, self-extinguishing
- Resistant to most oils, greases, acids and bases
- Silicone free
- RoHS compliant

### Technical data

#### Voltage

$U_0/U$  0.6/1 kV

Test voltage 4000 V

Insulation resistance min. 20 M $\Omega$  × km

#### Temperature range

moving -5 °C to +70 °C

fixed -40 °C to +80 °C

#### Minimum bending radius

moving  $D \times 15$

fixed  $D \times 4$

#### Burning behavior

Flame-retardant according to VDE 0482 part 265-2, DIN EN 50265-2, IEC 60332-1

Part-No.	Number of conductors/cross-section	Outer $\varnothing$ ca. mm	Weight kg/100 m	Cu-Index kg/100 m
116501	(4G1.5)	11.5	21.7	10.4
116502	(4G2.5)	13.3	31.6	17.0
116503	(4G4)	15.3	40.7	23.6
116504	(4G6)	17.6	52.1	31.9
116505	(4G10)	21.1	86.6	57.6
116506	(4G16)	24.5	120.0	80.7
116507	(4G25)	29.4	182.0	116.9
116508	(4G35)	32.2	239.9	168.6

### Construction

- Bare copper wire, super finely stranded according to DIN VDE 0295 Kl. 5 or IEC 60228 cl. 5
- Special PVC
- Conductors black with white number print according to DIN EN 50334
- Ground conductor green/yellow according to DIN EN 50334
- Inner jacket special PVC
- Braid from tinned copper wire, optical coverage  $\geq 85\%$
- Jacket special PVC according to VDE 0281-1, matte, adhesion-free surface
- Jacket color black RAL 9005

CE These products are in conformity with the EU Low Voltage Directive 2006/95/EC

# PVC motor and frequency converter cables shielded

## LÜTZE SILFLEX® M XLPE 3 (C) PVC 0,6/1 kV 2XSL(ST)CY-JB motor connecting cable for frequency converter



### Application

- Flexible motor supply cable in machine and device construction, transport and conveyor technology, HVAC technology
- In dry and damp rooms
- For flexible applications without continuous flexing
- Easy installation and cable routing
- Low capacitance for long cable guide
- Low-loss power transmission

### Properties

- Protective conductor divided by three for improved symmetry and reduced induction
- Special XLPE insulation with low capacitance
- Increased temperature resistance (90 °C) for the conductor and jacket material
- High dielectric strength
- High current carrying capacity
- Specially suited to usage with frequency converters
- High active and passive interference resistance (EMC)
- PVC Flame-retardant, self-extinguishing
- Resistant to most oils, greases, acids and bases
- Silicone free
- RoHS compliant

### Technical data

Voltage	
U <sub>0</sub> /U	0.6/1 kV
Test voltage	
	4000 V
Insulation resistance	
	min. 500 MΩ × km
Temperature range	
moving	-5 °C to +70 °C
fixed	-30 °C to +90 °C
Minimum bending radius	
moving	D × 10 ≤ 12 mm D × 15 ≤ 20 mm D × 20 > 20 mm
fixed	D × 5 ≤ 12 mm D × 7,5 ≤ 20 mm D × 10 > 20 mm
Burning behavior	
	Flame-retardant and self-extinguishing according to DIN EN 60332-1-2

### Construction

- Bare copper wire, super finely stranded according to DIN VDE 0295 Kl. 5 or IEC 60228 cl. 5
- Conductor insulation Special XLPE
- Conductors color-coded according to Cenelec HD 308
- Ground conductor green/yellow according to DIN EN 50334
- Aluminium concealed foil shield
- Braid from tinned copper wire, optical coverage ≥ 85 %
- Jacket special-PVC
- Jacket color black RAL 9005

Part-No.	Number of conductors/cross-section	Outer Ø ca. mm	Weight kg/100 m	Cu-Index kg/100 m
101501	(3×1.5+3G0.25)	9.3	21.2	9.1
101502	(3×2.5+3G0.5)	10.4	27.6	15.2
101503	(3×4+3G0.75)	11.9	44.6	22.4
101504	(3×6+3G1.0)	13.6	58.2	29.8
101505	(3×10+3G1.5)	16.1	79.4	49.1
101506	(3×16+3G2.5)	18.6	118.8	72.3
101507	(3×25+3G4)	24.4	171.3	113.8
101494	(3×35+3G6)	28.1	240.2	153.5
101495	(3×50+3G10)	32.0	271.8	220.8
101496	(3×70+3G10)	35.8	363.6	287.1
101508	(3×95+3G16)	40.9	355.6	395.3
101509	(3×120+3G16)	43.8	507.7	483.6

CE These products are in conformity with the EU Low Voltage Directive 2006/95/EC

# PVC servo cables - shielded

## LÜTZE SILFLEX® M (C) PVC SERVO 0.6/1 kV

Motor/energy supply cable for Siemens and other systems



### Application

- For Siemens 6FX5008\* standard system (and similar)
- Connection cable motor or motor/brake especially for frequency converters and SERVO drives in machine and plant construction, transport and conveyor technology
- Flexible construction for easy installation
- Suitable for static laying and slight movement of machine components (not C-track)
- Low capacitance for high dielectric strength for long cable guide from inverter to motor
- In dry and damp rooms
- Especially for industrial environments in mechanical and system engineering

### Properties

- Low capacitance for high dielectric strength
- High active and passive interference resistance (EMC)
- PVC, flame-retardant and self-extinguishing
- Orange RAL 2003 per DESINA
- Resistant to most oils, greases, alcohol-free benzines and kerosene
- Silicone free
- RoHS compliant

### Technical data

UL approval	AWM 2570
Nominal voltage	1000 V 80 °C
Voltage	
$U_0/U$	0.6/1 kV
Test voltage	4000 V
Insulation resistance	min. 500 M $\Omega$ × km
Temperature range	
moving	-5 °C to +80 °C
fixed	-25 °C to +80 °C
Minimum bending radius	
moving	D × 10
fixed	D × 6
Burning behavior	Flame-retardant according to VDE 0482 part 265-2, DIN EN 50265-2, IEC 60332-1, UL 1581 section 1080 VW-1, CSA FT 1

### Construction

- Bare copper wire, super finely stranded according to DIN VDE 0295 Kl. 5 or IEC 60228 cl. 5
- Conductor insulation Special TPM/PP
- Conductor marking Power conductors black with number print U/L1/C/L+, V/L2, W/L3/D/L-
- Ground conductor green/yellow according to DIN EN 50334 in the top layer
- G = with green/yellow ground conductor, × = without ground conductor
- Signal strands: white/black (1 pair)
- Fleece wrap over cable core
- Braid from tinned copper wire, optical coverage  $\geq$  85 %
- Jacket special-PVC, matte, adhesion-free surface
- Jacket color orange RAL 2003

Part-No.	Number of conductors/cross-section	SIEMENS designation	Outer Ø ca. mm	Weight kg/100 m	Cu-Index kg/100 m
<b>Construction without signal strands</b>					
116401	(4G1.5)	1BB11*	8.4	13.1	8.8
116402	(4G2.5)	1BB21*	10.6	21.9	13.2
116403	(4G4)	1BB31*	11.5	31.2	19.5
116404	(4G6)	1BB41*	13.2	38.0	28.0
116405	(4G10)	1BB51*	16.5	62.0	44.5
116406	(4G16)	1BB61*	21.2	106.0	71.5
116407	(4G25)	1BB25*	25.0	165.0	111.0
116408	(4G35)	1BB35*	31.8	231.0	154.0
<b>Construction with 1 signal pair</b>					
116415	(4G1.5+(2×1.5))	1BA11*	11.6	24.8	15.5
116416	(4G2.5+(2×1.5))	1BA21*	13.0	31.0	19.5
116417	(4G4+(2×1.5))	1BA31*	14.0	44.5	27.5
116418	(4G6+(2×1.5))	1BA41*	15.8	55.4	35.3
116419	(4G10+(2×1.5))	1BA51*	18.5	80.6	53.7
116420	(4G16+(2×1.5))	1BA61*	23.6	108.5	75.9
116421	(4G25+(2×1.5))	1BA25*	28.5	168.5	115.4

CE These products are in conformity with the EU Low Voltage Directive 2006/95/EC

\*Siemens article designations are registered trademarks of Siemens AG

# PVC feedback cables - shielded

## LÜTZE SILFLEX® (C) PVC FEEDBACK

Feedback cable for Siemens DRIVE-CLIQ 6FX5008 standard system



### Application

- Digital feedback cable compatible with Siemens DRIVE-CLIQ standard system
- In dry and damp rooms
- For flexible applications without continuous flexing

### Properties

- High active and passive interference resistance (EMC)
- PVC Flame-retardant, self-extinguishing
- Resistant to most oils, greases, acids and bases
- Silicone free
- RoHS compliant

### Technical data

UL approval	AWM 2502
Nominal voltage	30 V 80 °C
Test voltage	500 V
Insulation resistance	min. 20 MΩ × km
Temperature range	
moving	-5 °C to +80 °C
fixed	-25 °C to +80 °C
Minimum bending radius	
moving	D × 15
fixed	D × 7.5
Burning behavior	Flame-retardant according to VDE 0482 part 265-2, DIN EN 50265-2, IEC 60332-1,

### Construction

- Bare copper wire, super finely stranded according to DIN VDE 0295 Kl. 5 or IEC 60228 cl. 5
- Conductor insulation Special thermoplast
- Conductors color-coded
- Braid from tinned copper wire, optical coverage ≥ 85 %
- Jacket special PVC TM2 according to VDE 0281-1, matte, adhesion-free surface
- Jacket color green RAL 6018

Part-No.	Number of strands/cross-section/ strand colors	Outer Ø ca. mm	Weight kg/100 m	Cu-Index kg/100 m
<b>For Siemens system DRIVE-CLIQ 2DC00</b>				
104313	(2×2×AWG26) green/yellow/blue/pink	6.4	7.3	3.4
104341	(2×2×AWG26+2×AWG22) AWG26: green/yellow/blue/pink AWG22: red/black	6.8	8.5	4.2

# LÜTZE SUPERFLEX® and LÜTZE SUPERFLEX® PLUS



## LÜTZE SUPERFLEX®

← *connected*

**LÜTZE SUPERFLEX® sets Industry Standards:  
longevity, reliability, flexibility**

LÜTZE SUPERFLEX® flexing cables are specifically designed for use in continuous motion applications such as drag chains.

Find here more informations  
about LÜTZE SUPERFLEX®  
<http://bit.ly/ZUdgUK>



# PUR motor cables - C-track compatible - unshielded

## LÜTZE SUPERFLEX® PLUS M PUR 0.6/1 kV Motor/energy supply cable For highest requirements



### Application

- Motor connection cable, specifically for machine and device construction, transport and conveyor technology
- Due to full PUR jacket and TPE / HGI conductor insulation optimally suited for c-tracks, extremely rough operating conditions and aggressive coolants and lubricants
- Especially for industrial environments, machines and plants

### Properties

- Very good alternating bending strength
- Low adhesion, abrasion-resistant, nick-resistant, tear-propagation-resistant
- Hydrolysis-resistant, microbe-resistant, and rot-resistant
- Weatherproof, ozone and UV resistant (normal lighting conditions)
- Good ruggedness and salt water resistance
- Excellent coolant and lubricant resistance
- Resistant to most oils, greases, alcohol-free benzines and kerosene
- Silicone free
- RoHS compliant

### Technical data

UL approval	AWM 21223
Nominal voltage	1000 V 80 °C
Voltage	
$U_0/U$	0.6/1 kV
Test voltage	4000 V
Insulation resistance	min. 500 MΩ × km
Temperature range	
moving	-25 °C to +80 °C
fixed	-40 °C to +80 °C
Minimum bending radius	
moving	D × 7.5
fixed	D × 4
Burning behavior	Flame-retardant according to VDE 0482 part 265-2, DIN EN 50265-2, IEC 60332-1, UL 1581 section 1080 VW-1, CSA FT 1
Halogen free	according to EN 50267-2-1

### Construction

- Bare copper wire, super finely stranded according to DIN VDE 0295 class 6, IEC 60228 class 6
- Conductor insulation Special TPE/HGI, UL certified
- Conductors black with white print according to DIN EN 50334
- Ground conductor green/yellow according to DIN EN 50334
- Conductors cabled in layers without mechanical stress, layer pitch optimised
- Fleece wrap over cable core
- Jacket special-PUR, matte, adhesion-free surface
- Jacket color black RAL 9005

Part-No.	Number of conductors/cross-section	Outer Ø ca. mm	Weight kg/100 m	Cu-Index kg/100 m
111370	4G1.5	8.2	10.5	5.8
111371	4G2.5	10.0	15.2	9.7
111372	4G4	11.6	22.2	15.5
111545	5G4	13.0	26.8	19.4
111373	4G6	13.6	33.8	23.3
111430	5G6	14.4	37.8	29.2
111374	4G10	16.8	55.5	39.1
111429	5G10	18.8	69.5	48.8
111375	4G16	20.4	78.8	62.2
111548	5G16	24.2	112.6	77.5
111376	4G25	24.2	120.8	96.0
111377	4G35	30.5	172.5	136.5
111378	4G50	36.5	265.1	200.1

CE These products are in conformity to the EC Low Voltage Directive 73/23/EWG or 93/68/EWG respectively

# PUR servo cables - C-track compatible - shielded

## LÜTZE SUPERFLEX® PLUS M (C) PUR SERVO 0.6/1 kV Supply line for Siemens and other systems For highest requirements



### Application

- Connection cable motor or motor/brake especially for frequency converters and SERVO drives in machine and plant construction, transport and conveyor technology
- Due to optimized cable construction optimally suited for continuous flexing applications in C-tracks
- Very good resistance against aggressive coolants and lubricants
- Especially for industrial environments in mechanical and system engineering

### Properties

- High active and passive interference resistance (EMC)
- Braided shield optimised for continuous flexible use
- Very good alternating bending strength
- Low adhesion, abrasion-resistant, nick-resistant, tear-propagation-resistant
- Hydrolysis-resistant, microbe-resistant, and rot-resistant
- Weatherproof, ozone and UV resistant (normal lighting conditions)
- Good ruggedness and salt water resistance
- Excellent coolant and lubricant resistance
- Resistant to most oils, greases, alcohol-free benzines and kerosene
- Silicone free
- RoHS compliant

### Technical data

UL approval	AWM 21223
Nominal voltage	1000 V 80 °C
Voltage $U_0/U$	0.6/1 kV
Test voltage	4000 V
Insulation resistance	min. 500 MΩ × km
Temperature range	
moving	-25 °C to +80 °C
fixed	-40 °C to +80 °C
Minimum bending radius	
moving	D × 10
fixed	D × 6
Burning behavior	Flame-retardant according to VDE 0482 part 265-2, DIN EN 50265-2, IEC 60332-1, UL 1581 section 1080 VW-1, CSA FT 1
Halogen free	according to EN 50267-2-1

### Construction

- Bare copper wire, super finely stranded according to DIN VDE 0295 class 6, IEC 60228 class 6
- Conductor insulation Special TPE, high glide
- Power conductors black with numbered print U/L1/C/L+, V/L2, W/L3/D/L-
- Ground conductor green/yellow according to DIN EN 50334  
G = with green/yellow ground conductor, × = without ground conductor
- Control pair color-coded (bk, wh)
- Control pair with braided shield and foil tape
- Conductors cabled in layers without mechanical stress, layer pitch optimised
- Fleece wrap over cable core
- Braid from tinned copper wire, optical coverage ≥ 85 %
- Jacket special-PUR, matte, adhesion-free surface
- Jacket color orange RAL 2003

Part-No.	Number of conductors/cross-section	SIE-MENS designation	Outer Ø ca. mm	Weight kg/100 m	Cu-Index kg/100 m
<b>Construction without signal strands</b>					
111879	(4G1.0)	-----*	7.4	10.8	6.5
111460	(4G1.5)	1BB11*	8.6	11.7	8.3
111461	(4G2.5)	1BB21*	10.8	17.3	13.0
111462	(4G4)	1BB31*	12.2	24.5	19.3
111463	(4G6)	1BB41*	14.0	36.5	27.5
111464	(4G10)	1BB51*	17.6	54.9	45.0
111465	(4G16)	1BB61*	21.2	84.9	72.0
111466	(4G25)	1BB25*	25.0	129.9	108.0
111467	(4G35)	1BB35*	28.8	169.2	152.4
111468	(4G50)	1BB50*	33.9	244.2	216.8
<b>Assembly with 1 signal pair</b>					
111420	(4G1.5+(2×1.5))	1BA11*	11.4	21.0	14.9
111421	(4G2.5+(2×1.5))	1BA21*	12.9	23.5	19.3
111422	(4G4+(2×1.5))	1BA31*	14.5	32.0	25.5
111423	(4G6+(2×1.5))	1BA41*	16.1	43.0	33.9
111424	(4G10+(2×1.5))	1BA51*	19.5	68.0	52.6
111425	(4G16+(2×1.5))	1BA61*	23.6	95.6	77.3
111426	(4G25+(2×1.5))	1BA25*	28.5	136.5	113.0
111427	(4G35+(2×1.5))	1BA35*	31.0	274.6	159.0
111428	(4G50+(2×1.5))	1BA50*	34.5	373.7	224.0

CE These products are in conformity with the EU Low Voltage Directive 2006/95/EC

\*Siemens article designations are registered trademarks of Siemens

AG  
see current catalogue



# PVC servo cables - C-track compatible - shielded

## LÜTZE SUPERFLEX® PLUS M (C) PUR SERVO 0.6/1 kV Supply line for Bosch Rexroth and other systems For highest requirements



### Application

- For Indramat\* system (and similar)
- Connection cable motor/brake especially for frequency converters and SERVO drives in machine and plant construction, transport and conveyor technology
- Due to Full PUR jacket and TPE / HGI conductor insulation optimally suited for c-tracks, extremely rough operating conditions and aggressive coolants and lubricants
- Especially for industrial environments in mechanical and system engineering

### Properties

- High active and passive interference resistance (EMC)
- Braided shield optimised for continuous flexible use
- Very good alternating bending strength
- Low adhesion, abrasion-resistant, nick-resistant, tear-propagation-resistant
- Hydrolysis-resistant, microbe-resistant, and rot-resistant
- Weatherproof, ozone and UV resistant (normal lighting conditions)
- Good ruggedness and salt water resistance
- Excellent coolant and lubricant resistance
- Resistant to most oils, greases, alcohol-free benzines and kerosene
- Silicone free
- RoHS compliant

### Technical data

UL approval	AWM 21223
Nominal voltage	1000 V 80 °C
Voltage $U_0/U$	0.6/1 kV
Test voltage	4000 V
Insulation resistance	min. 500 MΩ × km
Temperature range	
moving	-25 °C to +80 °C
fixed	-40 °C to +80 °C
Minimum bending radius	
moving	D × 10
fixed	D × 6
Burning behavior	Flame-retardant according to IEC 60332-1-2, EN 50265-1-2, UL 1581, CSA C22.2 No. 210.2 Flame Rating FT1
Halogen free	according IEC 60754-1, EN 50267-2-1

### Construction

- Bare copper wire, super finely stranded according to DIN VDE 0295 class 6, IEC 60228 class 6
- Conductor insulation Special TPE, high glide
- Power conductors black with number print (1, 2, 3)
- Ground conductor green/yellow according to DIN EN 50334  
G = with green/yellow ground conductor, × = without ground conductor
- Control pairs digits printing (5, 6) (7, 8)
- Control pair with braided shield and foil tape
- Conductors cabled in layers without mechanical stress, layer pitch optimised
- Fleece wrap over cable core
- Braid from tinned copper wire, optical coverage ≥ 85 %
- Jacket special-PUR, matte, adhesion-free surface
- Jacket color orange RAL 2003

Part-No.	Number of conductors/cross-section	INK* Description	Outer Ø ca. mm	Weight kg/100 m	Cu-Index kg/100 m
<b>Construction with two control pairs</b>					
111719	(4G0.75+2×(2×0.34))	-----	11.2	17.7	9.5
111270	(4G1.0+2×(2×0.75))	INK 0653	12.5	23.2	13.8
111271	(4G1.5+2×(2×0.75))	INK 0650	12.9	25.5	16.2
111279	(4G2.5+2×(2×1.0))	INK 0602	14.2	33.0	22.6
111388	(4G4+(2×1.0)+(2×1.5))	INK 0603	16.3	38.0	32.9
111998	(4G6+(2×1.0)+(2×1.5))	INK 0604	18.4	53.0	38.5
111762	(4G10+(2×1.0)+(2×1.5))	INK 0605	22.3	76.5	57.0
111276	(4G16+2×(2×1.5))	INK 0606	26.8	106.4	89.1
111277	(4G25+2×(2×1.5))	INK 0607	29.3	171.4	126.0
111278	(4G35+2×(2×1.5))	INK 0667	32.5	217.6	164.0

CE These products are in conformity with the EU Low Voltage Directive 2006/95/EC

\*Indramat article designations are registered trademarks

# PVC servo cables - C-track compatible - shielded

## LÜTZE SUPERFLEX® PLUS M (C) PUR SERVO 0.6/1 kV Supply line for Lenze and other systems For highest requirements



### Application

- Connection cable motor/brake especially for frequency converters and SERVO drives in machine and plant construction, transport and conveyor technology
- Due to Full PUR jacket and TPE / HGI conductor insulation optimally suited for c-tracks, extremely rough operating conditions and aggressive coolants and lubricants
- Especially for industrial environments in mechanical and system engineering

### Properties

- High active and passive interference resistance (EMC)
- Braided shield optimised for flexible use
- Very good alternating bending strength
- Low adhesion, abrasion-resistant, nick-resistant, tear-propagation-resistant
- Hydrolysis-resistant, microbe-resistant, and rot-resistant
- Weatherproof, ozone and UV resistant (normal lighting conditions)
- Good ruggedness and salt water resistance
- Excellent coolant and lubricant resistance
- Resistant to most oils, greases, alcohol-free benzines and kerosene
- Silicone free
- RoHS compliant

### Technical data

UL approval	AWM 21223
Nominal voltage	1000 V 80 °C
Voltage $U_0/U$	0.6/1 kV
Test voltage	4000 V
Insulation resistance	min. 500 M $\Omega$ × km
Temperature range	
moving	-25 °C to +80 °C
fixed	-40 °C to +80 °C
Minimum bending radius	
moving	D × 10
fixed	D × 6
Burning behavior	Flame-retardant according to VDE 0482 part 265-2, DIN EN 50265-2, IEC 60332-1, UL 1581 section 1080 VW-1, CSA FT 1
Halogen free	according to EN 50267-2-1

### Construction

- Bare copper wire, super finely stranded according to DIN VDE 0295 class 6, IEC 60228 class 6
- Conductor insulation Special TPE, high glide
- Power conductors black with numbered print U/L1/C/L+, V/L2, W/L3/D/L-
- Ground conductor green/yellow according to DIN EN 50334  
G = with green/yellow ground conductor, × = without ground conductor
- Control pair (black, white)
- Control pair with braided shield and foil tape
- Conductors cabled in layers without mechanical stress, layer pitch optimised
- Fleece wrap over cable core
- Braid from tinned copper wire, optical coverage  $\geq$  85 %
- Jacket special-PUR, matte, adhesion-free surface
- Jacket color orange RAL 2003

Part-No.	Number of conductors/cross-section	Outer $\varnothing$ ca. mm	Weight kg/100 m	Cu-Index kg/100 m
<b>For Lenze system (and similar)</b>				
111439	(4G1.0 + (2×0.5))	10.2	15.5	8.1
111536	(4G1.5+(2×0.5))	11.0	19.2	10.6
111997	(4G2.5+(2×0.5))	12.8	27.1	15.3
111763	(4G4+(2×1.0))	14.8	37.3	23.5
111764	(4G6+(2×1.0))	16.9	47.7	31.6
111765	(4G10+(2×1.0))	20.3	71.0	51.3

CE These products are in conformity to the EC Low Voltage Directive 73/23/EWG or 93/68/EWG respectively

# PVC servo cables - C-track compatible - shielded

## LÜTZE SUPERFLEX® PLUS M (C) PUR SERVO 0.6/1 kV Supply line for SEW and other systems For highest standards



### Application

- Connection cable motor/brake especially for frequency converters and SERVO drives in machine and plant construction, transport and conveyor technology
- Due to Full PUR jacket and TPE / HGI conductor insulation optimally suited for c-tracks, extremely rough operating conditions and aggressive coolants and lubricants
- Especially for industrial environments in mechanical and system engineering

### Properties

- High active and passive interference resistance (EMC)
- Braided shield optimised for continuous flexible use
- Very good alternating bending strength
- Low adhesion, abrasion-resistant, nick-resistant, tear-propagation-resistant
- Hydrolysis-resistant, microbe-resistant, and rot-resistant
- Weatherproof, ozone and UV resistant (normal lighting conditions)
- Good ruggedness and salt water resistance
- Excellent coolant and lubricant resistance
- Resistant to most oils, greases, alcohol-free benzines and kerosene
- Silicone free
- RoHS compliant

### Technical data

UL approval	AWM 21223
Nominal voltage	1000 V 80 °C
Voltage $U_0/U$	0.6/1 kV
Test voltage	4000 V
Insulation resistance	min. 1000 M $\Omega$ × km
Temperature range	
moving	-25 °C to +80 °C
fixed	-40 °C to +80 °C
Minimum bending radius	
moving	D × 10
fixed	D × 6
Burning behavior	Flame-retardant according to VDE 0482 part 265-2, DIN EN 50265-2, IEC 60332-1, UL 1581 section 1080 VW-1, CSA FT 1
Halogen free	according to EN 50267-2-1

### Construction

- Bare copper wire, super finely stranded according to DIN VDE 0295 class 6, IEC 60228 class 6
- Conductor insulation Special TPE, high glide
- Power conductors black with numbered print U/L1/C/L+, V/L2, W/L3/D/L-
- Ground conductor green/yellow according to DIN EN 50334  
G = with green/yellow ground conductor, × = without ground conductor
- Three elements: number printing (1, 2, 3)
- Three elements with control pair with braided shield and foil tape
- Conductors cabled in layers without mechanical stress, layer pitch optimised
- Fleece wrap over cable core
- Braid from tinned copper wire, optical coverage  $\geq$  85 %
- Jacket special-PUR
- Jacket color orange RAL 2003

Part-No.	Number of conductors/cross-section	Outer $\varnothing$ ca. mm	Weight kg/100 m	Cu-Index kg/100 m
<b>For SEW system (and similar), with inner jacket and three elements</b>				
111560	(4G1.5+(3×1.0))	11.8	24.4	13.9
111561	(4G2.5+(3×1.0))	13.7	30.6	18.3
111562	(4G4+(3×1.0))	14.7	39.6	25.6
111563	(4G6+(3×1.5))	17.0	52.9	34.4
111564	(4G10+(3×1.5))	20.5	73.0	52.2

CE These products are in conformity to the EC Low Voltage Directive 73/23/EWG or 93/68/EWG respectively

# PUR servo cables - C-track compatible - shielded

## LÜTZE SUPERFLEX® PLUS M (C) PUR HYBRID SERVO 0,6/1 kV combined power supply cable for servo motors with Hiperface DSL® interface For the highest of standards



### Application

- Combined power supply cable with motor supply, brake and digital feedback especially for SERVO drives in machine and plant construction, transport and conveyor technology
- Due to Full PUR jacket and TPE / HGI conductor insulation optimally suited for c-tracks, extremely rough operating conditions and aggressive coolants and lubricants
- Especially for industrial environments in mechanical and system engineering

### Properties

- High active and passive interference resistance (EMC)
- Braided shield optimised for continuous flexible use
- Very good alternating bending strength
- Low adhesion, abrasion-resistant, nick-resistant, tear-propagation-resistant
- Hydrolysis-resistant, microbe-resistant, and rot-resistant
- Weatherproof, ozone and UV resistant (normal lighting conditions)
- Good ruggedness and salt water resistance
- Excellent coolant and lubricant resistance
- Resistant to most oils, greases, alcohol-free benzines and kerosene
- Silicone free
- RoHS compliant

### Technical data

UL approval	AWM 21223
Nominal voltage	1000 V 80 °C
Voltage $U_0/U$	0.6/1 kV
Test voltage	3000 V
Insulation resistance	min. 500 M $\Omega$ × km
Temperature range	
moving	-25 °C to +80 °C
fixed	-40 °C to +80 °C
Minimum bending radius	
moving	D × 7.5
fixed	D × 5
Burning behavior	Flame-retardant according to VDE 0482 part 265-2, DIN EN 50265-2, IEC 60332-1, UL 1581 section 1080 VW-1, CSA FT 1
Halogen free	according to EN 50267-2-1

### Construction

- Bare copper wire in compliance with IEC 60228 Cl. 6 in Bare copper wire in compliance with IEC 60228 Cl. 6 in Bare copper wire in compliance with IEC 60228 Cl. 6
- Conductor insulation Special polyolefin mix
- Power conductors black with number print U/L1/C/L+, V/L2, W/L3/D/L-
- Ground conductor green/yellow according to DIN EN 50334  
G = with green/yellow ground conductor, × = without ground conductor
- Control pair color-coded (bw, wb), BUS element color-coded (bw, wb)
- Control pair and BUS element each with braided shield and foil tape
- Strands for the power supply, element brake and element BUS braided together
- Fleece wrap over cable core
- Braid from tinned copper wire, optical coverage ≥ 85 %
- PUR halogen free jacket
- Jacket color orange RAL 2003

Part-No.	Number of conductors/cross-section	Outer Ø ca. mm	Weight kg/100 m	Cu-Index kg/100 m
111598	(4G0.75+(2×0.34)+(2×AWG22))	11.8	21.1	13.3
111599	(4G1,0+(2×0,75)+(2×AWG22))	11.4	19.0	11.2
111600	(4G1,5+(2×0,75)+(2×AWG22))	13.2	25.2	16.0
111601	(4G2,5+(2×1,0)+(2×AWG22))	14.0	31.4	21.5
111602	(4G4+(2×1.0)+(2×AWG22))	15.8	40.8	28.8
111603	(4G6+(2×1.0)+(2×AWG22))	17.8	51.2	37.2
111604	(4G10+(2×1.5)+(2×AWG22))	21.0	77.9	57.3
111605	(4G16+(2×1.5)+(2×AWG22))	26.0	119.8	87.0

CE These products are in conformity with the EU Low Voltage Directive 2006/95/EC

# PUR motor cables - C-track compatible

## LÜTZE SUPERFLEX® PLUS PUR 0.6/1 kV

### Motor/energy supply cable

### For highest requirements



#### Application

- Performance conductor, specifically for machine and device engineering, transport and conveyor technology
- As motor supply or grounding cable
- Due to full PUR jacket and TPE conductor insulation optimally suited for c-tracks, extremely rough operating conditions and aggressive coolants and lubricants
- Especially for industrial environments, machines and plants

#### Properties

- Halogen-free, no corrosive gases
- Very good alternating bending strength
- Low adhesion, abrasion-resistant, nick-resistant, tear-propagation-resistant
- Hydrolysis-resistant, microbe-resistant, and rot-resistant
- Weatherproof, ozone and UV resistant (normal lighting conditions)
- Good ruggedness and salt water resistance
- Excellent coolant and lubricant resistance
- Resistant to most oils, greases, alcohol-free benzines and kerosene
- Silicone free
- RoHS compliant

#### Technical data

UL approval	AWM 21223 AWM 10587
Nominal voltage	1000 V 80 °C
Test voltage	4000 V
Temperature range	
moving	-25 °C to +80 °C
fixed	-40 °C to +80 °C
Minimum bending radius	
moving	D × 7.5
fixed	D × 6
Burning behavior	Flame-retardant according to VDE 0482 part 265-2 DIN EN 50265-2, IEC 60332-1 UL 1581 section 1080 VW-1 CSA FT 1
Halogen free	according to EN 50267-2-1

#### Construction

- Bare copper wire, super finely stranded according to DIN VDE 0295 class 6, IEC 60228 class 6
- Conductor insulation Special TPE, high glide
- Braid shield (optional) from galvanised Cu wire, optical coverage ≥ 85 %
- Full polyurethane jacket, matte, adhesion-free surface
- Jacket color Black RAL 9005, GreenYellow available on request

Part-No.	Number of strands/cross-section/ strand colors	Outer Ø ca. mm	Weight kg/100 m	Cu-Index kg/100 m
<b>Without shield, black</b>				
111136	1×6	7.1	9.0	5.6
111126	1×10	8.4	13.8	9.3
111127	1×16	9.8	20.5	14.8
111128	1×25	11.4	30.6	23.3
111129	1×35	13.4	43.1	32.6
111130	1×50	15.2	57.2	47.8
111131	1×70	16.6	78.3	64.5
111132	1×95	19.2	104.3	88.8
111133	1×120	22.2	130.2	120.0
<b>Without screen, insulation and jacket greenyellow</b>				
111241	1G6	7.1	9.0	5.6
111243	1G10	8.4	13.8	9.3
111197	1G16	9.8	20.5	14.8
111337	1G25	11.4	30.6	23.3
111285	1G35	13.4	43.1	32.6

CE These products are in conformity with the EU Low Voltage Directive 2006/95/EC

# PUR motor cables - C-track compatible

## LÜTZE SUPERFLEX® PLUS (C) PUR 0.6/1 kV Motor/energy supply cable, for highest requirements



### Application

- Performance conductor, specifically for machine and device engineering, transport and conveyor technology
- As motor supply or grounding cable
- Due to full PUR jacket and TPE conductor insulation optimally suited for c-tracks, extremely rough operating conditions and aggressive coolants and lubricants
- Especially for industrial environments, machines and plants

### Properties

- Halogen-free, no corrosive gases
- Very good alternating bending strength
- Low adhesion, abrasion-resistant, nick-resistant, tear-propagation-resistant
- Hydrolysis-resistant, microbe-resistant, and rot-resistant
- Weatherproof, ozone and UV resistant (normal lighting conditions)
- Good ruggedness and salt water resistance
- Excellent coolant and lubricant resistance
- Resistant to most oils, greases, alcohol-free benzines and kerosene
- Silicone free
- RoHS compliant

### Technical data

UL approval	AWM 21223 AWM 10587
Nominal voltage	1000 V 80 °C
Test voltage	4000 V
Temperature range	
moving	-25 °C to +80 °C
fixed	-40 °C to +80 °C
Minimum bending radius	
moving	D × 7.5
fixed	D × 6
Burning behavior	Flame-retardant according to VDE 0482 part 265-2 DIN EN 50265-2, IEC 60332-1 UL 1581 section 1080 VW-1 CSA FT 1
Halogen free	according to EN 50267-2-1

### Construction

- Bare copper wire, super finely stranded according to DIN VDE 0295 class 6, IEC 60228 class 6
- Conductor insulation Special TPE, high glide
- Braid shield (optional) from galvanised Cu wire, optical coverage ≥ 85 %
- Full polyurethane jacket, matte, adhesion-free surface
- Jacket color Black RAL 9005, GreenYellow available on request

Part-No.	Number of strands/cross-section/ strand colors	Outer Ø ca. mm	Weight kg/100 m	Cu-Index kg/100 m
<b>With CU shield, black</b>				
111288	(1×6)	7.7	11.5	7.7
111289	(1×10)	9.0	17.1	12.1
111290	(1×16)	10.4	24.1	18.1
111291	(1×25)	12.0	35.3	27.3
111292	(1×35)	14.0	48.1	37.3
111293	(1×50)	15.8	63.1	53.1
111294	(1×70)	17.4	85.3	70.6
111295	(1×95)	20.2	114.6	98.0
111296	(1×120)	23.4	143.1	132.0

CE These products are in conformity with the EU Low Voltage Directive 2006/95/EC

# PUR feedback cables - C-track compatible

## LÜTZE SUPERFLEX® PLUS (C) PUR FEEDBACK Encoder cables for Siemens and other systems For highest requirements in drive technology



### Application

- Incremental encoder cable, connection cable for tacho sensor, brake sensor, speed sensor
- Due to Full PUR jacket and TPE conductor insulation optimally suited for c-tracks, extremely rough operating conditions and aggressive coolants and lubricants
- Especially for industrial environments in mechanical and system engineering

### Properties

- High active and passive interference resistance (EMC)
- Braided shield optimised for continuous flexible use
- Very good alternating bending strength
- Low adhesion, abrasion-resistant, nick-resistant, tear-propagation-resistant
- Hydrolysis-resistant, microbe-resistant, and rot-resistant
- Weatherproof, ozone and UV resistant (normal lighting conditions)
- Good ruggedness and salt water resistance
- Excellent coolant and lubricant resistance
- Resistant to most oils, greases, alcohol-free benzines and kerosene
- Silicone free
- RoHS compliant

### Technical data

UL approval	AWM 20236
Nominal voltage	30 V 80 °C
Test voltage	500 V
Insulation resistance	min. 200 MΩ × km
Temperature range	
moving	-25 °C to +80 °C
fixed	-40 °C to +80 °C
Minimum bending radius	
moving	D × 12
fixed	D × 6
Burning behavior	Flame-retardant according to VDE 0482 part 265-2, DIN EN 50265-2, IEC 60332-1, UL 1581 section 1080 VW-1, CSA FT 1
Halogen free	according to EN 50267-2-1

### Construction

- Bare copper wire, super finely stranded according to DIN VDE 0295 class 6, IEC 60228 class 6
- Conductor insulation Special-TPE
- Conductors color-coded for specific system
- Conductors cabled in layers without mechanical stress, layer pitch optimised
- Fleece wrap over cable core
- Braid from tinned copper wire, optical coverage ≥ 85 %
- Full polyurethane jacket, matte, adhesion-free surface
- Jacket color green RAL 6018

Part-No.	Number of strands/cross-section/ strand colors	SIE- MENS designa- tion	Outer Ø ca. mm	Weight kg/100 m	Cu-Index kg/100 m
<b>For Siemens 6FX8000* standard system (and similar)</b>					
111412	(8×2×0.18) black/brown, red/orange, yellow/green, blue/violet, grey/white, whiteblack/whitebrown, whitered/white- orange, whitegreen/whiteyellow	1BD11*	8.1	13.1	7.3
111456	(4×0.5+4×2×0.38) 0.5: whiteblue, whiteblack, whitered, whiteyellow 0.38: black/brown, red/orange, green/ yellow, blue/violet	1BD21*	9.2	13.2	8.6
111459	(2×(0.5)+3×(2×0.14)) 0.5: black, red 0.14: black/brown, red/orange, green/ yellow	1BD31*	8.7	12.8	6.9
111458	(2×0.5+3×(2×0.14)+4×0.14) 0.5: brownblue, brownred (0.14) black/brown, red/orange, green/ yellow 0.14: blue, grey, whiteblack, whiteyel- low	1BD41*	9.0	12.2	6.1
111457	(2×0.5+3×(2×0.14)+4×0.23+4×0.14) 0.5: brownblue, brownred 0.23: greenblack, greenred, brownyel- low, browngrey (0.14) black/brown, red/orange, yellow/ green 0.14: blue, grey, whiteblack, whiteyel- low	1BD51*	9.6	15.3	9.3
111453	(4×2×0.18) black/brown, red/orange, green/yellow, blue/violet	1BD61*	6.4	7.6	3.2
111452	(2×2×0.18) Star quad, black, red, orange, brown	1BD71*	5.0	4.2	2.2
111454	(12×0.23) black, brown, red, orange, green, yel- low, blue, violet, grey, white, whiteblack, whitebrown	1BD81*	6.7	8.5	4.7
<b>For Siemens-System Drive Cliq standard system (and similar)</b>					
104310	(2×2×0.15+1×2×0.34) 0.34: red/black 0.15: pink/blue, yellow/green	2DC00*	6.8	7.3	3.4

CE These products are in conformity to the EC Low Voltage Direc-  
tive 73/23/EWG or 93/68/EWG respectively

\*Siemens and DRIVE CliQ are registered trademarks

# PUR feedback cables - C-track compatible

## LÜTZE SUPERFLEX® PLUS (C) PUR FEEDBACK Feedback cables for Bosch-Rexroth and other systems For highest requirements in drive technology



### Application

- Incremental encoder cable, connection cable for tacho sensor, brake sensor, speed sensor
- Due to Full PUR jacket and TPE conductor insulation optimally suited for c-tracks, extremely rough operating conditions and aggressive coolants and lubricants
- Especially for industrial environments in mechanical and system engineering

### Properties

- High active and passive interference resistance (EMC)
- Braided shield optimised for continuous flexible use
- Very good alternating bending strength
- Low adhesion, abrasion-resistant, nick-resistant, tear-propagation-resistant
- Hydrolysis-resistant, microbe-resistant, and rot-resistant
- Weatherproof, ozone and UV resistant (normal lighting conditions)
- Good ruggedness and salt water resistance
- Excellent coolant and lubricant resistance
- Resistant to most oils, greases, alcohol-free benzines and kerosene
- Silicone free
- RoHS compliant

### Technical data

UL approval	AWM 20233
Nominal voltage	300 V 80 °C
Test voltage	2000 V
Insulation resistance	min. 200 MΩ × km
Temperature range	
moving	-25 °C to +80 °C
fixed	-40 °C to +80 °C
Minimum bending radius	
moving	D × 12
fixed	D × 6
Burning behavior	Flame-retardant according to VDE 0482 part 265-2, DIN EN 50265-2, IEC 60332-1, UL 1581 section 1080 VW-1, CSA FT 1
Halogen free	according to EN 50267-2-1

### Construction

- Bare copper wire, super finely stranded according to DIN VDE 0295 class 6, IEC 60228 class 6
- Conductor insulation Special-TPE
- Conductors color-coded for specific system
- Conductors cabled in layers without mechanical stress, layer pitch optimised
- Fleece wrap over cable core
- Braid from tinned copper wire, optical coverage ≥ 85 %
- Jacket special-PUR, matte, adhesion-free surface
- Jacket color orange RAL 2003

Part-No.	Number of strands/cross-section/ strand colors	INK* De- scription	Outer Ø ca. mm	Weight kg/100 m	Cu-Index kg/100 m
<b>For Bosch-Rexroth system (and similar)</b>					
110941	(2×1.0+4×2×0.25) 1.0: white, brown 0.25: brown/green, grey/pink, blue/violet, red/black	INK-0209*	8.9	12.0	6.4
111780	(2×0.5+4×2×0.25) 0.5: white, brown 0.25: brown/green, grey/pink, blue/violet, red/black	INK-0448*	8.7	10.0	5.9
110940	(9×0.5) Strand color according to DIN 47100	INK-0208*	8.8	12.5	7.5
111495	(4×1.0+4×2×0.14+(4×0.14)) 1.0: blue, whitegreen, browngreen, white 0.14: grey/pink, yellow/violet, green/brown, red/black (0.14): greenblack, blueblack, yellowblack, redblack	INK-0532*	9.5	13.7	9.6
111781	(2×2×0.25+2×0.5) 0.5: white, brown 0.25: red/black, gray, pink	INK-0750*	7.6	9.0	4.2

CE These products are in conformity with the EU Low Voltage Directive 2006/95/EC

\*Indramat article designations are registered trademarks



# PUR feedback cables - C-track compatible

## LÜTZE SUPERFLEX® PLUS (C) PUR FEEDBACK Feedback cables for Lenze and other systems For highest requirements in drive technology



### Application

- Incremental encoder cable, connection cable for tacho sensor, brake sensor, speed sensor
- Due to Full PUR jacket and TPE conductor insulation optimally suited for c-tracks, extremely rough operating conditions and aggressive coolants and lubricants
- Especially for industrial environments in mechanical and system engineering

### Properties

- High active and passive interference resistance (EMC)
- Braided shield optimised for continuous flexible use
- Very good alternating bending strength
- Low adhesion, abrasion-resistant, nick-resistant, tear-propagation-resistant
- Hydrolysis-resistant, microbe-resistant, and rot-resistant
- Weatherproof, ozone and UV resistant (normal lighting conditions)
- Good ruggedness and salt water resistance
- Excellent coolant and lubricant resistance
- Resistant to most oils, greases, alcohol-free benzines and kerosene
- Silicone free
- RoHS compliant

### Technical data

UL approval	AWM 20233
Nominal voltage	300 V 80 °C
Test voltage	2000 V
Insulation resistance	min. 200 MΩ × km
Temperature range	
moving	-25 °C to +80 °C
fixed	-40 °C to +80 °C
Minimum bending radius	
moving	D × 12
fixed	D × 6
Burning behavior	Flame-retardant according to VDE 0482 part 265-2, DIN EN 50265-2, IEC 60332-1, UL 1581 section 1080 VW-1, CSA FT 1
Halogen free	according to EN 50267-2-1

### Construction

- Bare copper wire, super finely stranded according to DIN VDE 0295 class 6, IEC 60228 class 6
- Conductor insulation Special-TPE
- Conductors color-coded for specific system
- Conductors cabled in layers without mechanical stress, layer pitch optimised
- Fleece wrap over cable core
- Jacket special-PUR, matte, adhesion-free surface
- Jacket color green RAL 6018

Part-No.	Number of strands/cross-section/ strand colors	LENZE description*	Outer Ø ca. mm	Weight kg/100 m	Cu-Index kg/100 m
<b>For Lenze system (and similar)</b>					
111769	3×(2×0.14)+(2×0.5) (0.5): white/brown (0.14): green/yellow, blue/red, grey/ pink	EWLR	9.3	10.7	4.4
111771	4×(2×0.14)+2×(1.0) (1.0): brown/white (0.14): green/yellow, blue/red, green/ pink, black/violet	EWLE	11.2	14.5	6.5

CE These products are in conformity to the EC Low Voltage Directive 73/23/EWG or 93/68/EWG respectively  
\*Lenze article designations are registered trademarks

# PUR feedback cables - C-track compatible

## LÜTZE SUPERFLEX® PLUS (C) PUR FEEDBACK Feedback cables for SEW and other systems For highest requirements in drive technology



### Application

- Incremental encoder cable, connection cable for tachometer, brake sensor, speed sensor
- Due to Full PUR jacket and TPE conductor insulation optimally suited for c-tracks, extremely rough operating conditions and aggressive coolants and lubricants
- Especially for industrial environments in mechanical and system engineering

### Properties

- High active and passive interference resistance (EMC)
- Braided shield optimised for continuous flexible use
- Very good alternating bending strength
- Low adhesion, abrasion-resistant, nick-resistant, tear-propagation-resistant
- Hydrolysis-resistant, microbe-resistant, and rot-resistant
- Weatherproof, ozone and UV resistant (normal lighting conditions)
- Good ruggedness and salt water resistance
- Excellent coolant and lubricant resistance
- Resistant to most oils, greases, alcohol-free benzines and kerosene
- Silicone free
- RoHS compliant

### Technical data

UL approval	AWM 20233
Nominal voltage	300 V 80 °C
Test voltage	2000 V
Insulation resistance	min. 200 MΩ × km
Temperature range	
moving	-25 °C to +80 °C
fixed	-50 °C to +80 °C
Minimum bending radius	
moving	D × 12
fixed	D × 6
Burning behavior	Flame-retardant according to VDE 0482 part 265-2, DIN EN 50265-2, IEC 60332-1, UL 1581 section 1080 VW-1, CSA FT 1
Halogen free	according to EN 50267-2-1

### Construction

- Bare copper wire, super finely stranded according to DIN VDE 0295 class 6, IEC 60228 class 6
- Conductor insulation Special-TPE
- Conductors color-coded for specific system
- Conductors cabled in layers without mechanical stress, layer pitch optimised
- Fleece wrap over cable core
- Braid from tinned copper wire, optical coverage ≥ 85 %
- Jacket special-PUR, matte, adhesion-free surface
- Jacket color green RAL 6018

Part-No.	Number of strands/cross-section/ strand colors	Outer Ø ca. mm	Weight kg/100 m	Cu-Index kg/100 m
<b>For SEW system (and similar)</b>				
111772	(5×2×0.25) white/brown, green/yellow, grey/pink, blue/red, black/violet	8.8	9.0	4.9
111773	(6×2×0.25) white/brown, green/yellow, grey/pink, blue/red, black/violet, greypink/redblue	9.4	10.5	5.9

CE These products are in conformity to the EC Low Voltage Directive 73/23/EWG or 93/68/EWG respectively

# PUR feedback cables - C-track compatible

## LÜTZE SUPERFLEX® PLUS (C) PUR FEEDBACK Feedback cables for Allen-Bradley and other systems For highest requirements in drive technology



### Application

- Incremental encoder cable, connection cable for tacho sensor, brake sensor, speed sensor
- Due to optimized cable construction optimally suited for continuous flexing applications in C-tracks
- Very good resistance against aggressive coolants and lubricants
- Especially for industrial environments in mechanical and system engineering

### Properties

- High active and passive interference resistance (EMC)
- Braided shield optimised for continuous flexible use
- Very good alternating bending strength
- Low adhesion, abrasion-resistant, nick-resistant, tear-propagation-resistant
- Hydrolysis-resistant, microbe-resistant, and rot-resistant
- Weatherproof, ozone and UV resistant (normal lighting conditions)
- Good ruggedness and salt water resistance
- Excellent coolant and lubricant resistance
- Resistant to most oils, greases, alcohol-free benzines and kerosene
- Silicone free
- RoHS compliant

### Technical data

UL approval	AWM 21223
Nominal voltage	1000 V 80 °C
Test voltage	2000 V
Insulation resistance	min. 200 MΩ × km
Temperature range	
moving	-25 °C to +80 °C
fixed	-40 °C to +80 °C
Minimum bending radius	
moving	D × 10
fixed	D × 6
Burning behavior	Flame-retardant according to VDE 0482 part 265-2, DIN EN 50265-2, IEC 60332-1, UL 1581 section 1080 VW-1, CSA FT 1
Halogen free	according to EN 50267-2-1

### Construction

- Bare copper wire, super finely stranded according to DIN VDE 0295 class 6, IEC 60228 class 6
- Conductor insulation Special-TPE
- Conductors color-coded for specific system
- Conductors cabled in layers without mechanical stress, layer pitch optimised
- Fleece wrap over cable core
- Braid from tinned copper wire, optical coverage ≥ 85 %
- Jacket special-PUR, matte, adhesion-free surface
- Jacket color green RAL 6018

Part-No.	Number of strands/cross-section/ strand colors	Outer Ø ca. mm	Weight kg/100 m	Cu-Index kg/100 m
<b>For Allen Bradley system (and similar)</b>				
111489	(2×AWG16+2×AWG22+6×2×AWG26) AWG 16: grey, white/grey AWG 22: orange, white/orange AWG 26: blackwhite/black, redwhite/red, greenwhite/green, bluewhite/blue, brownwhite/brown, greywhite/grey	10.8	18.0	12.0
111488	(5×2×AWG22) blackwhite/black, redwhite/red greenwhite/green, greywhite/grey, organgewwhite/orange	9.2	10.7	5.4

CE These products are in conformity to the EC Low Voltage Directive 73/23/EWG or 93/68/EWG respectively

# PUR feedback cables - C-track compatible

## LÜTZE SUPERFLEX® PLUS (C) PUR FEEDBACK Feedback cables for Heidenhain and other systems For highest requirements in drive technology



### Application

- Incremental encoder cable, connection cable for tacho sensor, brake sensor, speed sensor
- Due to Full PUR jacket and TPE conductor insulation optimally suited for c-tracks, extremely rough operating conditions and aggressive coolants and lubricants
- Especially for industrial environments in mechanical and system engineering

### Properties

- High active and passive interference resistance (EMC)
- Braided shield optimised for continuous flexible use
- Very good alternating bending strength
- Low adhesion, abrasion-resistant, nick-resistant, tear-propagation-resistant
- Hydrolysis-resistant, microbe-resistant, and rot-resistant
- Weatherproof, ozone and UV resistant (normal lighting conditions)
- Good ruggedness and salt water resistance
- Excellent coolant and lubricant resistance
- Resistant to most oils, greases, alcohol-free benzines and kerosene
- Silicone free
- RoHS compliant

### Technical data

UL approval	AWM 20233
Nominal voltage	300 V 80 °C
Test voltage	2000 V
Insulation resistance	min. 200 MΩ × km
Temperature range	
moving	-25 °C to +80 °C
fixed	-40 °C to +80 °C
Minimum bending radius	
moving	D × 12
fixed	D × 6
Burning behavior	Flame-retardant according to VDE 0482 part 265-2, DIN EN 50265-2, IEC 60332-1, UL 1581 section 1080 VW-1, CSA FT 1
Halogen free	according to EN 50267-2-1

### Construction

- Bare copper wire, super finely stranded according to DIN VDE 0295 class 6, IEC 60228 class 6
- Conductor insulation Special-TPE
- Conductors color-coded for specific system
- Conductors cabled in layers without mechanical stress, layer pitch optimised
- Fleece wrap over cable core
- Braid from tinned copper wire, optical coverage ≥ 85 %
- Jacket special-PUR, matte, adhesion-free surface
- Jacket color black RAL 9005

Part-No.	Number of strands/cross-section/ strand colors	Outer Ø ca. mm	Weight kg/100 m	Cu-Index kg/100 m
<b>For Heidenhain system (and similar)</b>				
111774	(2×(0.5)+3×(2×0.14)) (0.5): white, brown (0.14): green/yellow, grey/pink, blue/red	8.5	10.0	6.2
111776	(2×(1.0)+3×(2×0.14)) (1.0): white, brown (0.14): green/yellow, grey/pink, blue/red	9.1	11.5	6.5
111418	(4×0.5+4×2×0.14+(4×0.14)) 0.5: white, blue, brown/green, white/green 0.14: yellow/violet, grey/pink, brown/green, red/black (0.14): green/black, blue/black, yellow/black, red/black	8.7	12.3	6.0
111777	(4×0.5+4×2×0.14) 0.5: white, blue, brown/green, white/green 0.14: yellow/violet, grey/pink, brown/green, red/black	8.6	9.2	4.8

CE These products are in conformity to the EC Low Voltage Directive 73/23/EWG or 93/68/EWG respectively

# PUR feedback cables - C-track compatible

## LÜTZE SUPERFLEX® PLUS (C) PUR FEEDBACK Feedback cables for various systems For highest requirements in drive technology



### Application

- Incremental encoder cable, connection cable for tacho sensor, brake sensor, speed sensor
- Due to Full PUR jacket and TPE conductor insulation optimally suited for c-tracks, extremely rough operating conditions and aggressive coolants and lubricants
- Especially for industrial environments in mechanical and system engineering

### Properties

- High active and passive interference resistance (EMC)
- Braided shield optimised for continuous flexible use
- Very good alternating bending strength
- Low adhesion, abrasion-resistant, nick-resistant, tear-propagation-resistant
- Hydrolysis-resistant, microbe-resistant, and rot-resistant
- Weatherproof, ozone and UV resistant (normal lighting conditions)
- Good ruggedness and salt water resistance
- Excellent coolant and lubricant resistance
- Resistant to most oils, greases, alcohol-free benzenes and kerosene
- Silicone free
- RoHS compliant

### Technical data

UL approval	AWM 20233
Nominal voltage	300 V 80 °C
Test voltage	2000 V
Insulation resistance	min. 200 MΩ × km
Temperature range	
moving	-25 °C to +80 °C
fixed	-40 °C to +80 °C
Minimum bending radius	
moving	D × 12
fixed	D × 6
Burning behavior	Flame-retardant according to VDE 0482 part 265-2, DIN EN 50265-2, IEC 60332-1, UL 1581 section 1080 VW-1, CSA FT 1
Halogen free	according to EN 50267-2-1

### Construction

- Bare or tin-plated copper wire (vz), super finely stranded according to DIN VDE 0295 class 6, IEC 60228 class 6
- Special-TPE
- Conductors color-coded for specific system
- Conductors cabled in layers without mechanical stress, layer pitch optimised
- Fleece wrap over cable core
- Braid from tinned copper wire, optical coverage ≥ 85 %
- Jacket special-PUR, matte, adhesion-free surface
- Jacket color green RAL 6018

Part-No.	Number of strands/cross-section/ strand colors	Outer Ø ca. mm	Weight kg/100 m	Cu-Index kg/100 m
<b>For System Fanuc (with drain wire)</b>				
111490	(5×0.5+1×2×0.18)vz 0.5: green, yellow, grey, pink, blue 0.18: white/brown	7.5	8.1	4.9
111491	(5×0.5+2×2×0.18)vz 0.5: green, yellow, grey, pink, blue 0.18: white/brown, black/violet	7.8	9.3	6.3
111492	(6×0.5+3×2×0.18)vz 0.5: black 1-3, red 4-6 0.18: black/red, white/red, black/white	8.7	9.8	6.3
<b>For NUM system</b>				
111416	4×(2×AWG22) black/white, black/green, black/blue, black/red	10.3	11.0	6.6
111417	(4×(2×0.22)+2×(2×0.5)) (0.5): black/orange, black/green (AWG24): black/white, black/pink, black/blue, black/red	12.5	18.0	11.9
<b>For Berger Lahr system</b>				
111479	(1×2×0.5+5×2×0.25) 0.5: blue, red 0.25: white/brown, green/yellow, grey/ pink, black/violet, greypink/redblue	8.7	14.0	5.8
<b>For B+R system</b>				
111437	(3×2×AWG24/19) white/brown, green/yellow, grey/pink	6.6	6.9	2.7
111438	(2×0.5+5×2×0.14) 0.5: blue, red 0.14: white/brown, green/yellow, grey/ pink, black/violet, greypink/redblue	7.8	12.5	5.0
<b>Individual pair shields for various resolver systems</b>				
111778	(3×(2×0.25)) DIN 47100 TP	9.6	13.6	6.9
111779	(4×(2×0.25)) DIN 47100 TP	10.2	18.1	9.5

CE These products are in conformity to the EC Low Voltage Directive 73/23/EWG or 93/68/EWG respectively



## 6. Cable assemblies

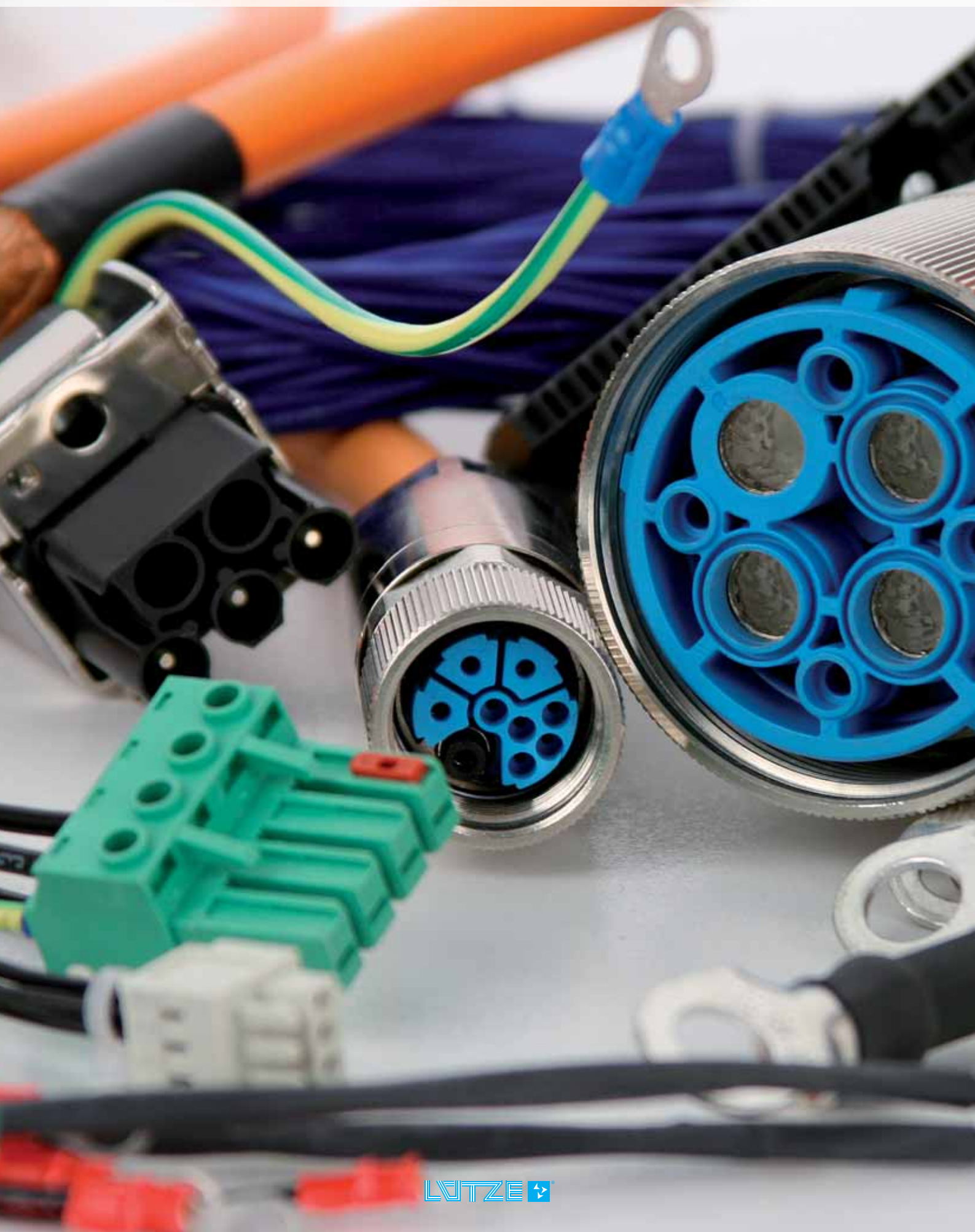

## 6. Cable assemblies



### Customer specific solutions with LÜTZE Tamper-proof connector

Plastic-coated pin connector for industrial applications 6.4 - 6.5



### Allen-Bradley® according to 2090 Standard for fixed wiring

Servo motor cable 6.6  
Feedback cable 6.7

### for c-tracks

Servo motor cable 6.8  
Feedback cable 6.9  
Hybrid cables 6.10



### Bosch Rexroth® Standard

#### for c-tracks

Servo motor cable according to IKG Standard 6.11  
Servo motor cable according to RKL Standard 6.12  
Feedback cable according to IKS Standard 6.13



### Lenze® Standard

Servo motor cables 6.14  
Feedback cable 6.15



### SEW® Standard

Servo motor cables 6.16  
Feedback cable 6.18



### SIEMENS® according to 6FX5002 for fixed wiring

Servo cable assemblies without brake, Base cable 6.19  
Servo cable assemblies with brake, Base cable 6.21  
Servo cable assemblies without brake, Extension 6.23  
Servo cable assemblies with brake, Extension 6.24  
Feedback cable DRIVE-CLIQ®, Base cable 6.25

### SIEMENS® according to 6FX8002 for c-tracks

Servo cable assemblies without brake, Base cable 6.26  
Servo cable assemblies with brake, Base cable 6.28  
Servo cable assemblies without brake, Extension 6.30  
Servo cable assemblies with brake, Extension 6.31  
Feedback cable DRIVE-CLIQ®, Base cable 6.32  
Feedback cable, Base cable or Extension 6.33



## 6. Cable assemblies

### Pre-assembled cables for different applications



Siemens Simatic SPS / S7 connector

6.34



Ethernet- Patch cable Cat.5E / Cat.6

6.35



USB 3.0 connection cables

6.36



Prefabricated coil cables

6.37

### Questionnaire

Questionnaire for coil cables

6.38

Questionnaire for LÜTZE Tamper-proof connector

6.39

### Ordering instructions:

The LÜTZE Art.no. consists of two blocks that are separated by a dot:

6 digits before the dot: technical design

4-digits after the dot: length code in cm

### Special features:

- No minimum order quantity
- All intermediate lengths in steps of 0.5 m are available within a short time
- When ordering, please specify serial number and length key
- Additional types on request

Customer-specific solutions on request

Our project planning sheet for cable assemblies can be found in the download area under [www.luetze.com](http://www.luetze.com)



# Always the right connection **LÜTZE** cable assemblies



## Sealed as if potted!

LÜTZE Tamper-proof plastic moulded round connectors M23 for industrial use offer the user an economical and, at the same time, safe solution for the electrical connection of machines and systems.

The LÜTZE range offers varying numbers of terminations and cable lengths. That is numbers of terminations from 6 to 28 and ratings of up to 30 A at 630 V. Therefore

robust, safe cabling is available for numerous signal and power applications.

The integrated protection against kinking and the inner metal housing with 360° EMC shielding ensure the cable assemblies meet the requirements for the industrial sector - **they really are sealed as if potted!**

### Further advantages:

- Tamper-proof: unauthorised opening of the connector housing and incorrect connection in the connector are therefore excluded
- 100 % compatible with SIEMENS®, BOSCH REXROTH®, LENZE®, SEW®...
- Manufacture from a batch size of 1
- Available at short notice
- Protection class IP66/67

# ction: lies

**Coil cables for the highest mechanical stresses - manufactured according to your specifications, e.g. high-performance machines,**



lifting platforms and many other moving applications. Also suitable for outdoor use ideal for millions of cycles without failure!



## Customised solutions

Every system is different. Take advantage of our experience in cable assembly! Our experts can document and provide solutions

to your applications as they have access to more than 1.700 cables, plugs, strain reliefs and cable conduits.



# Servomotor cables for fixed installation

According to Allen-Bradley 2090 standard



## Application

- For Allen-Bradley standard
- Connecting lead especially for frequency converters and SERVO drives in machine and plant construction, transport and conveyor technology
- Conform with NFPA79 for tool machine wiring
- Very suitable for extreme operating conditions and high interference signals
- In dry, damp and wet rooms
- Especially for industrial environments in mechanical and system engineering

## Properties

- High active and passive interference resistance (EMC)
- Easy installation
- Resistant to most mineral and vegetable-based cutting oils
- UV-resistant
- Silicone and talcum free
- RoHS compliant

## Technical data

UL approval	cULus
Nominal voltage	600 V UL TC 600 V UL MTW 600 V UL AWM 105 °C 1000 V WTTC
Voltage $U_0/U$	0.6/1 kV
Test voltage	4000 V
Insulation resistance	min. 500 M $\Omega$ × km
Temperature range	
fixed	-40 °C to +90 °C
Minimum bending radius	
fixed	D × 6
Approvals	UL TC-ER, UL/AWM/CE, UL MTW, WTTC UL AWM Style 20328, Class 1, Div. 2 per NEC Art. 336, 392, 501 C(UL) TC, CIC FT4, UL 1277 Oil Res I and II, RoHS

## Construction

- AWG conductor
- Conductor insulation Special PVC/nylon
- Conductor marking power conductor: brown, black, blue
- Ground conductor green/yellow according to DIN EN 50334
- Control pair color-coded black, white
- Control pair with foil tape and braided shield.
- Conductors cabled in layers without mechanical stress, layer pitch optimised
- Braid from tinned copper wire, optical coverage  $\geq 85\%$
- Jacket special-TPE, matte, adhesion-free surface
- Jacket color orange RAL 2003

Part-No.	Allen-Bradley designation	Length m	Number of conductors/ cross-section	Outer $\varnothing$ ca. mm
<b>Base cable SpeedTec</b>				
193966.1000	2090-CPWM7DF-16AAxx*	10.0	(4GAWG16)	10.5
193956.1000	2090-CPWM7DF-14AAxx*	10.0	(4GAWG14)	11.6
193352.1000	2090-CPWM7DF-12AAxx*	10.0	(4GAWG12)	13.1
193306.1000	2090-CPWM7DF-10AAxx*	10.0	(4GAWG10)	16.5
193353.1000	2090-CPWM7DF-08AAxx*	10.0	(4GAWG8)	21.0
193960.1000	2090-CPBM7DF-16AAxx*	10.0	(4GAWG16+(2×AWG18))	12.1
193990.1000	2090-CPBM7DF-14AAxx*	10.0	(4GAWG14+(2×AWG18))	12.8
193356.1000	2090-CPBM7DF-12AAxx*	10.0	(4GAWG12+(2×AWG18))	14.2
193962.1000	2090-CPBM7DF-10AAxx*	10.0	(4GAWG10+(2×AWG18))	18.1
193357.1000	2090-CPBM7DF-08AAxx*	10.0	(4GAWG8+(2×AWG18))	22.5
193961.1000	2090-CPBM7DF-06AAxx*	10.0	(4GAWG6+(2×AWG18))	24.6
193362.1000	2090-CPBM7DF-04AAxx*	10.0	(4GAWG4+(2×AWG18))	29.5
193369.1000	2090-CPBM7DF-02AAxx*	10.0	(4GAWG2+(2×AWG18))	34.1

\* Allen-Bradley article designations are registered trademarks of Rockwell Allen Bradley, and are for reference purposes only. The product photos are not to scale and do not represent detailed images of the respective products.

# Signal cables for fixed installation

## According to Allen-Bradley 2090 standard

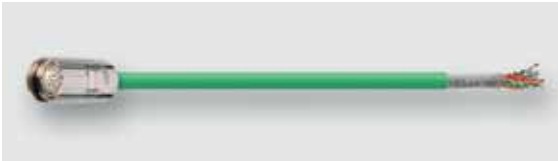

Part-No.	Allen-Bradley designation	Length m	Number of conductors/cross-section	Outer Ø ca. mm
<b>Base cable SpeedTec</b>				
193959.1000	2090-CFBM7DF-CEAAxx*	10.0	(5×2×AWG22)	9.9
193358.1000	2090-CFBM7DD-CEAAxx*	10.0	(5×2×AWG22)	9.9
<b>DIN thread</b>				
193337.1000	2090-XXNFMF-Sxx*	10.0	(2×AWG16+2×AWG22+6×2×AWG26)	13.6

### Application

- Feedback cables for Allen Bradley drives
- Conform with NFPA79 for tool machine wiring
- Very suitable for extreme operating conditions and high interference signals
- In dry, damp and wet rooms
- Especially for industrial environments in mechanical and system engineering

### Properties

- High active and passive interference resistance (EMC)
- Easy installation
- Specially developed TPE jacket for superior oil-resistance according to UL 1581
- Resistant to most mineral and vegetable-based cutting oils
- UV-resistant
- Silicone and talcum-free
- RoHS compliant

### Technical data

Nominal voltage	300 V UL PLTC-ER 300 V UL CM 600 V UL AWM 90 °C
Test Voltage	1.5 kV
Temperature range	-30 °C to +105 °C (static -40 °C)
Minimum bending radius	min. D × 6, static
Burning behavior	Flame retardant per UL Vertical-Tray UL VW-1
Oil resistance	UL1581 4 days in Oil at 100 °C 60 days in Oil at 75 °C
Approvals	A1410001: UL PLTC-ER, meets NEC 725 and Class I Div. 2 A1410002: UL CM, meets NEC 800 Both: UL AWM Style 20626 CE RoHS REACH

### Construction

- AWG conductor
- Flexible finely stranded bare copper conductors
- Conductor insulation Special PVC
- Conductor marking Conductors color-coded for specific system
- Aluminium laminated film shield, braid made of tinned copper wires, optical coverage approx. 85 %, drain wire
- Outer jacket Extreme oil-resistant TPE jacket
- Jacket color green RAL 6018

\* Allen-Bradley article designations are registered trademarks of Rockwell Allen Bradley, and are for reference purposes only. The product photos are not to scale and do not represent detailed images of the respective products.

# Servomotor cables for C-tracks

According to Allen-Bradley 2090 standard



## Application

- Servo cables for Allen Bradley drives
- Due to optimized cable construction optimally suited for continuous flexing applications in C-tracks
- Very good resistance against aggressive coolants and lubricants
- Especially for industrial environments in machines and plants

## Properties

- High active and passive interference resistance (EMC)
- Silicone free
- RoHS compliant

## Technical data

UL approval	AWM 21223
Nominal voltage	1000 V 80 °C
Test voltage	4000 V
Temperature range	
moving	-25 °C to +80 °C
fixed	-40 °C to +80 °C
Minimum bending radius	
moving	D × 10
fixed	D × 6
Burning behavior	Flame-retardant according to VDE 0482 T 265-2, IEC 60332-1, UL 1581 section 1080 VW-1, CSA FT 1
Halogen free	according to DIN EN 50267-2-1

## Construction

- Bare copper wire, super finely stranded according to DIN VDE 0295 class 6, IEC 60228 class 6
- Special TPE/HGI conductor insulation, UL qualified
- Conductor marking Power conductors black with numbered print U/L 1/C/L+, V/L2, W/L3/D/L-
- Ground conductor green/yellow according to DIN EN 50334
- Control pair color-coded (bw, wb) or numbered (5/6/7/8)
- Control pair with braided shield and foil tape
- Conductors cabled in layers without mechanical stress, layer pitch optimised
- Fleece wrap over cable core
- Braid from tinned copper wire, optical coverage ≥ 85 %
- Outer jacket Full polyurethane jacket, matte, adhesion-free surface
- Jacket color orange RAL 2003

Part-No.	Allen-Bradley designation	Length m	Number of conductors/ cross-section	Outer Ø ca. mm
<b>Base cable SpeedTec</b>				
193309.1000	2090-CPWM7DF-16AFxx*	10.0	(4G1.5)	8.6
193307.1000	2090-CPWM7DF-10AFxx*	10.0	(4G6.0)	14.0
193989.1000	2090-CPBM7DF-10AFxx*	10.0	(4G6.0+(2×1.5))	16.1
193991.1000	2090-CPBM7DF-16AFxx*	10.0	(4G1.5+(2×1.5))	11.4
193308.1000	2090-CPWM7DF-14AFxx*	10.0	(4G2.5)	10.8
193957.1000	2090-CPBM7DF-14AFxx*	10.0	(4G2.5+(2×1.5))	12.9
193311.1000	2090-CPWM7DF-08AFxx*	10.0	(4G10)	17.6
193355.1000	2090-CPBM7DF-08AFxx*	10.0	(4G10+(2×1.5))	19.5
<b>DIN thread</b>				
193985.1000	2090-CPBM4DF-16AFxx*	10.0	(4G1.5+(2×1.5))	12.9
193303.1000	2090-CPWM4DF-16AFxx*	10.0	(4G1.5)	8.6
193983.1000	2090-CPBM4DF-14AFxx*	10.0	(4G2.5+(2×1.5))	14.2
193301.1000	2090-CPWM4DF-14AFxx*	10.0	(4G2.5)	10.8
<b>Extension SpeedTec</b>				
193996.1000	2090-CPBM7E7-16AFxx*	10.0	(4G1.5+(2×1.5))	11.4
193994.1000	2090-CPBM7E7-10AFxx*	10.0	(4G6.0+(2×1.5))	16.1
193360.1000	2090-CPBM7E7-14AFxx*	10.0	(4G2.5+(2×1.5))	12.9
193361.1000	2090-CPBM7E7-08AFxx*	10.0	(4G10+(2×1.5))	19.5

\* Allen-Bradley article designations are registered trademarks of Rockwell Allen Bradley, and are for reference purposes only. The product photos are not to scale and do not represent detailed images of the respective products.

# Signal cables for C-tracks

## According to Allen-Bradley 2090 standard

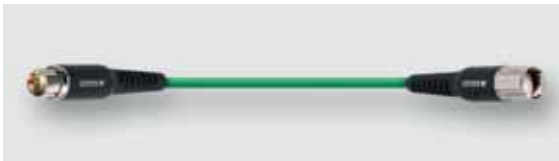

Part-No.	Allen-Bradley designation	Length m	Number of conductors/cross-section	Outer Ø ca. mm
<b>Base cable SpeedTec</b>				
193977.1000	2090-CFBM7DF-CEAFxx*	10.0	(5×2×AWG22)	9.2
193958.1000	2090-CFBM7DF-CDAFxx*	10.0	(2×AWG16+2×AWG22+6×2×AWG26)	10.8
193350.1000	2090-CFBM7DD-CEAFxx*	10.0	(5×2×AWG22)	9.2
<b>DIN thread</b>				
193973.1000	2090-CFBM4DF-CDAFxx*	10.0	(2×AWG16+2×AWG22+6×2×AWG26)	10.8
<b>Extension SpeedTec</b>				
193979.1000	2090-CFBM7E7-CEAFxx*	10.0	(5×2×AWG22)	9.2
193978.1000	2090-CFBM7E7-CDAFxx*	10.0	(2×AWG16+2×AWG22+6×2×AWG26)	10.8

### Application

- Servo feedback cables for Allen Bradley drives
- Due to optimized cable construction optimally suited for continuous flexing applications in C-tracks
- Very good resistance against aggressive coolants and lubricants
- Especially for industrial environments in machines and plants

### Properties

- High active and passive interference resistance (EMC)
- Silicone free
- RoHS compliant

### Technical data

UL approval	AWM 21223
Nominal voltage	1000 V 80 °C
Temperature range	
moving	-25 °C to +80 °C
fixed	-40 °C to +80 °C
Minimum bending radius	
moving	D × 12
fixed	D × 6
Burning behavior	Flame-retardant according to VDE 0482 T 265-2, IEC 60332-1, UL 1581 section 1080 VW-1, CSA FT 1
Halogen free	according to DIN EN 50267-2-1

### Construction

- Bare copper wire, super finely stranded according to DIN VDE 0295 class 6, IEC 60228 class 6
- Special TPE, UL certified
- Conductor marking Conductors color-coded for specific system
- Ground conductor green/yellow according to DIN EN 50334
- G = with green/yellow ground conductor, × = without ground conductor
- Conductors cabled in layers without mechanical stress, layer pitch optimised
- Fleece wrap over cable core
- Braid from tinned copper wire, optical coverage ≥ 85 %
- Outer jacket Full polyurethane jacket, matte, adhesion-free surface
- Jacket color green RAL 6018

\* Allen-Bradley article designations are registered trademarks of Rockwell Allen Bradley, and are for reference purposes only. The product photos are not to scale and do not represent detailed images of the respective products.

# Hybrid cables for C-tracks

According to Allen-Bradley 2090 standard



Part-No.	Allen-Bradley designation	Length m	Number of conductors/cross-section	Outer Ø ca. mm
<b>Base cable SpeedTec</b>				
193371.1000	2090-CSWM1DF-18AFxx*	10.0	(4G1.0+(2×AWG22))	11.8
193370.1000	2090-CSWM1DF-14AFxx*	10.0	(4G2.5+(2×AWG22))	14.0
193376.1000	2090-CSWM1DF-10AFxx*	10.0	(4G6+(2×AWG22))	17.8
193366.1000	2090-CSBM1DF-18AFxx*	10.0	(4G1,0+(2×0,75)+(2×AWG22))	11.8
193364.1000	2090-CSBM1DF-14AFxx*	10.0	(4G2,5+(2×1,0)+(2×AWG22))	14.0
193375.1000	2090-CSBM1DF-10AFxx*	10.0	(4G6+(2×1.0)+(2×AWG22))	17.8
<b>Extension SpeedTec</b>				
193373.1000	2090-CSBM1E1-18AFxx*	10.0	(4G1,0+(2×0,75)+(2×AWG22))	11.8
193374.1000	2090-CSBM1E1-14AFxx*	10.0	(4G2,5+(2×1,0)+(2×AWG22))	14.0

## Application

- Combined power supply cable with motor supply, brake and digital feedback especially for SERVO drives in machine and plant construction, transport and conveyor technology
- Due to Full PUR jacket and TPE / HGI conductor insulation optimally suited for c-tracks, extremely rough operating conditions and aggressive coolants and lubricants
- Especially for industrial environments in mechanical and system engineering

## Properties

- High active and passive interference resistance (EMC)
- Braided shield optimised for continuous flexible use
- Very good alternating bending strength
- Low adhesion, abrasion-resistant, nick-resistant, tear-propagation-resistant
- Hydrolysis-resistant, microbe-resistant, and rot-resistant
- Weatherproof, ozone and UV resistant (normal lighting conditions)
- Good ruggedness and salt water resistance
- Excellent coolant and lubricant resistance
- Resistant to most oils, greases, alcohol-free benzines and kerosene
- Halogen free
- Silicone and talcum free
- RoHS compliant

## Technical data

UL approval	AWM 21223
Nominal voltage	1000 V 80 °C
Test voltage	3000 V
Insulation resistance	min. 500 MΩ × km
Temperature range	
moving	-25 °C to +80 °C
fixed	-40 °C to +80 °C
Minimum bending radius	
moving	D × 7.5
fixed	D × 5
Burning behavior	Flame-retardant according to VDE 0482 T 265-2, DIN EN 50265-2, IEC 60332-1-2, UL 1581 section 1080 VW-1, CSA FT 1
Halogen free	according to DIN EN 50267-2-1

## Construction

- Bare copper wire, finely stranded according to DIN VDE 0295 class 6, IEC 60228 class 6
- Conductor insulation Polyolefin
- Conductor marking Power conductors black with numbered print U/L1/C/L+, V/L2, W/L3/D/L-
- Ground conductor green/yellow according to DIN EN 50334 G = with green/yellow ground conductor, × = without ground conductor
- Control pair color-coded (bw, wb), BUS element color-coded (bw, wb)
- Control pair and BUS element each with braided shield and foil tape
- Conductor for the power supply, element brake and element BUS braided together
- Fleece wrap over cable core
- Braid from tinned copper wire, optical coverage ≥ 85 %
- Jacket special-PUR, matte, adhesion-free surface
- Jacket color orange RAL 2003

\* Allen-Bradley article designations are registered trademarks of Rockwell Allen Bradley, and are for reference purposes only. The product photos are not to scale and do not represent detailed images of the respective products.



# Servomotor cables for C-tracks

According to Bosch Rexroth IKG standard



## Application

- Motor cable for Bosch Rexroth SERVO drives
- Full PUR jacket and TPE conductor insulation optimally suited for c-tracks, extremely rough operating conditions, aggressive coolants and lubricants

## Properties

- Silicone free
- RoHS-compliant

## Technical data

UL approval	cURus
Nominal voltage	1000 V 80 °C
Voltage	
$U_0/U$	0.6/1 kV
Insulation resistance	min. 500 MΩ × km
Temperature range	
moving	-25 °C to +80 °C
fixed	-40 °C to +80 °C
Minimum bending radius	
moving	D × 10
fixed	D × 6
Burning behavior	Flame-retardant according to VDE 0482 T 265-2, DIN EN 50265/2, IEC 60332-1, UL 1581 section 1080 VW-1 CSA FT 1
Halogen free	according to DIN EN 50267-2-1
Product photo	The product photos are not to scale and do not represent detailed images of the respective products.

## Construction

- Jacket color orange RAL 2003

Part-No.	INDRAMAT designation	Length m	Number of conductors/ cross-section	Outer Ø ca. mm
193040.1000	IKG 0006/10.0*	10.0	(4G1.5+2×(2×0.75))	11.8
193071.1000	IKG 0050/10.0*	10.0	(4G2.5+2×(2×0.75))	13.5
193048.1000	IKG 0081/10.0*	10.0	(4G6+2×(2×1.5))	18.0
193067.1000	IKG 0143/10.0*	10.0	(4G16+2×(2×1.5))	23.0
193041.1000	IKG 0314/10.0*	10.0	(4G2.5+2×(2×0.75))	13.5
193072.1000	IKG 0331/10.0*	10.0	(4G0.75+2×(2×0.5))	9.4
193073.1000	IKG 0332/10.0*	10.0	(4G0.75+2×(2×0.5))	9.4
193043.1000	IKG 4009/10.0*	10.0	(4G1.5+2×(2×0.75))	11.8
193042.1000	IKG 4016/10.0*	10.0	(4G1.5+2×(2×0.75))	11.8
193020.1000	IKG 4017/10.0*	10.0	(4G1.5+2×(2×0.75))	11.8
193045.1000	IKG 4018/10.0*	10.0	(4G1.5+2×(2×0.75))	11.8
193046.1000	IKG 4020/10.0*	10.0	(4G1.5+2×(2×0.75))	11.8
193074.1000	IKG 4047/10.0*	10.0	(4G1.5+2×(2×0.75))	11.8
193080.1000	IKG 4050/10.0*	10.0	(4G1.5+2×(2×0.75))	11.8
193049.1000	IKG 4055/10.0*	10.0	(4G1.5+2×(2×0.75))	11.8
193068.1000	IKG 4060/10.0*	10.0	(4G1.5+2×(2×0.75))	11.8
193044.1000	IKG 4067/10.0*	10.0	(4G2.5+2×(2×0.75))	13.5
193050.1000	IKG 4070/10.0*	10.0	(4G2.5+2×(2×0.75))	13.5
193051.1000	IKG 4087/10.0*	10.0	(4G4+2×(2×1.5))	15.5
193052.1000	IKG 4090/10.0*	10.0	(4G4+2×(2×1.5))	15.5
193053.1000	IKG 4107/10.0*	10.0	(4G6+2×(2×1.5))	18.0
193054.1000	IKG 4117/10.0*	10.0	(4G4+2×(2×1.5))	15.5
193055.1000	IKG 4118/10.0*	10.0	(4G6+2×(2×0.75))	18.0
193056.1000	IKG 4119/10.0*	10.0	(4G1.0+2×(2×0.75))	11.1
193057.1000	IKG 4122/10.0*	10.0	(4G10+2×(2×1.5))	20.1
193058.1000	IKG 4127/10.0*	10.0	(4G10+2×(2×1.5))	20.1
193059.1000	IKG 4138/10.0*	10.0	(4G1.0+2×(2×0.75))	11.1
193060.1000	IKG 4139/10.0*	10.0	(4G2.5+2×(2×0.75))	13.5
193069.1000	IKG 4150/10.0*	10.0	(4G6+2×(2×1.5))	18.0
193061.1000	IKG 4172/10.0*	10.0	(4G16+2×(2×1.5))	23.0
193062.1000	IKG 4176/10.0*	10.0	(4G10+2×(2×1.5))	20.1
193063.1000	IKG 4186/10.0*	10.0	(4G16+2×(2×1.5))	23.0
193064.1000	IKG 4193/10.0*	10.0	(4G16+2×(2×1.5))	23.0
193065.1000	IKG 4204/10.0*	10.0	(4G25+2×(2×1.5))	28.7
193066.1000	IKG 4224/10.0*	10.0	(4G35+2×(2×1.5))	31.4

\* Bosch Rexroth article designations are registered trademarks of Bosch Rexroth, and are for reference purposes only

# Servomotor cables for C-tracks

According to Bosch Rexroth RKL standard



## Application

- Motor cable for Bosch Rexroth SERVO drives
- Full PUR jacket and TPE conductor insulation optimally suited for c-tracks, extremely rough operating conditions, aggressive coolants and lubricants

## Properties

- Silicone free
- RoHS-compliant

## Technical data

UL approval	cURus
Nominal voltage	1000 V 80 °C
Voltage	
$U_0/U$	0.6/1 kV
Insulation resistance	min. 500 MΩ × km
Temperature range	
moving	-25 °C to +80 °C
fixed	-40 °C to +80 °C
Minimum bending radius	
moving	D × 10
fixed	D × 6
Burning behavior	Flame-retardant according to VDE 0482 T 265-2, DIN EN 50265/2, IEC 60332-1, UL 1581 section 1080 VW-1 CSA FT 1
Halogen free	according to DIN EN 50267-2-1
Product photo	The product photos are not to scale and do not represent detailed images of the respective products.

## Construction

- Jacket color orange RAL 2003

Part-No.	INDRAMAT designation	Length m	Number of conductors/cross-section	Outer Ø ca. mm
193240.1000	RKL 4302/10.0*	10.0	(4G1.0+2×(2×0.75))	11.1
193258.1000	RKL 4303/10.0*	10.0	(4G1.0+2×(2×0.75))	11.1
193241.1000	RKL 4306/10.0*	10.0	(4G1.5+2×(2×0.75))	11.8
193242.1000	RKL 4308/10.0*	10.0	(4G2.5+2×(2×0.75))	13.5
193243.1000	RKL 4309/10.0*	10.0	(4G2.5+2×(2×0.75))	13.5
193244.1000	RKL 4310/10.0*	10.0	(4G2.5+2×(2×0.75))	13.5
193263.1000	RKL 4311/10.0*	10.0	(4G1.5+2×(2×0.75))	11.8
193245.1000	RKL 4312/10.0*	10.0	(4G2.5+2×(2×0.75))	13.5
193257.1000	RKL 4314/10.0*	10.0	(4G4+2×(2×1.5))	15.5
193246.1000	RKL 4317/10.0*	10.0	(4G6+2×(2×1.5))	18.0
193247.1000	RKL 4318/10.0*	10.0	(4G6+2×(2×1.5))	18.0
193259.1000	RKL 4320/10.0*	10.0	(4G1.5+2×(2×0.75))	11.8
193252.1000	RKL 4321/10.0*	10.0	(4G2.5+2×(2×0.75))	13.5
193248.1000	RKL 4323/10.0*	10.0	(4G6+2×(2×1.5))	18.0
193249.1000	RKL 4324/10.0*	10.0	(4G10+2×(2×1.5))	20.1
193250.1000	RKL 4328/10.0*	10.0	(4G6+2×(2×1.5))	18.0
193251.1000	RKL 4329/10.0*	10.0	(4G10+2×(2×1.5))	20.1
193253.1000	RKL 4330/10.0*	10.0	(4G16+2×(2×1.5))	23.0
193254.1000	RKL 4331/10.0*	10.0	(4G25+2×(2×1.5))	28.7
193255.1000	RKL 4337/10.0*	10.0	(4G4+2×(2×1.5))	15.5
193256.1000	RKL 4338/10.0*	10.0	(4G6+2×(2×1.5))	18.0
193270.1000	RKL 4339/10.0*	10.0	(4G10+2×(2×1.5))	20.1
193271.1000	RKL 4340/10.0*	10.0	(4G16+2×(2×1.5))	23.0
193264.1000	RKL 4341/10.0*	10.0	(4G25+2×(2×1.5))	28.7
193260.1000	RKL 4343/10.0*	10.0	(4G2.5+2×(2×0.75))	13.5
193265.1000	RKL 4518/10.0*	10.0	(4G25+2×(2×1.5))	28.7
193266.1000	RKL 4519/10.0*	10.0	(4G35+2×(2×1.5))	31.4
193267.1000	RKL 4603/10.0*	10.0	(4G2.5+2×(2×0.75))	13.5
193268.1000	RKL 4606/10.0*	10.0	(4G6+2×(2×1.5))	18.0
193269.1000	RKL 4612/10.0*	10.0	(4G25+2×(2×1.5))	28.7
193261.1000	RKL 0013/10.0*	10.0	(4G0.75+2×(2×0.5))	9.4
193262.1000	RKL 0014/10.0*	10.0	(4G1.0+2×(2×0.75))	11.1

\* Bosch Rexroth article designations are registered trademarks of Bosch Rexroth, and are for reference purposes only

# Signal cables for C-tracks

According to Bosch Rexroth IKS standard



## Application

- Signal cables
- Due to full PUR jacket and TPE conductor insulation optimally suited for c-track, extremely rough operating conditions, aggressive coolants and lubricants

## Properties

- Silicone free
- RoHS-compliant

## Technical data

UL approval	cURus
Nominal voltage	300 V 80 °C
Voltage	
$U_0/U$	0.6/1 kV
Insulation resistance	min. 200 M $\Omega$ × km
Temperature range	
moving	-25 °C to +80 °C
fixed	-40 °C to +80 °C
Minimum bending radius	
moving	D × 12
fixed	D × 6
Burning behavior	Flame-retardant according to VDE 0482 T 265-2, DIN EN 50265/2, IEC 60332-1, UL 1581 section 1080 VW-1 CSA FT 1
Halogen free	according to DIN EN 50267-2-1
Product photo	The product photos are not to scale and do not represent detailed images of the respective products.

Part-No.	INDRAMAT designation	Length m	Outer Ø ca. mm
193164.1000	IKS 0230/10.0*	10.0	7.6
193165.1000	IKS 0232/10.0*	10.0	7.6
193620.1000	IKS 0253/10.0*	10.0	8.8
193154.1000	IKS 0257/10.0*	10.0	8.8
193145.1000	IKS 4001/10.0*	10.0	9.4
193146.1000	IKS 4038/10.0*	10.0	9.4
193147.1000	IKS 4042/10.0*	10.0	8.3
193148.1000	IKS 4043/10.0*	10.0	8.3
193149.1000	IKS 4103/10.0*	10.0	8.3
193150.1000	IKS 4151/10.0*	10.0	8.3
193151.1000	IKS 4153/10.0*	10.0	8.3
193152.1000	IKS 4374/10.0*	10.0	8.3
193153.1000	IKS 4389/10.0*	10.0	8.1
193140.1000	IKS 0251/10.0*	10.0	8.8
193142.1000	IKS 0301/10.0*	10.0	8.2
193143.1000	IKS 0321/10.0*	10.0	8.2
193144.1000	IKS 0374/10.0*	10.0	8.2
193141.1000	IKS 0252/10.0*	10.0	8.8
193000.1000	RKG 0002/10.0*	10.0	8.1
193034.1000	RKG 4200/10.0*	10.0	8.3
193001.1000	RKG 4201/10.0*	10.0	8.3
193047.1000	RKG 0033/10.0*	10.0	8.3

## Construction

- Jacket color orange RAL 2003

\* Bosch Rexroth article designations are registered trademarks of Bosch Rexroth, and are for reference purposes only

# Servomotor cables

## According to LENZE-Standard



### Application

- Servo cables for LENZE SERVO drives
- Especially for industrial environments, machines and plants

### For fixed installation

- PVC outer jacket, PVC conductor insulation, flame-retardant, suitable for fixed installation

### For use as C-track chains

- Due to full PUR jacket and TPE conductor insulation optimally suited for c-tracks, extremely rough operating conditions, aggressive coolants and lubricants

### Properties

- Silicone free
- RoHS-compliant

### Technical data

UL approval	cURus
Nominal voltage	1000 V 80 °C
Voltage	
$U_0/U$	0.6/1 kV
Insulation resistance	min. 500 M $\Omega$ × km
Temperature range	
PVC cable	
moving	-5 °C to +80 °C
fixed	-25 °C to +80 °C
PUR cable	
moving	-25 °C to +80 °C
fixed	-40 °C to +80 °C
Minimum bending radius	
moving	D × 10
fixed	D × 6
Burning behavior	Flame-retardant according to VDE 0482 T 265-2, DIN EN 50265/2, IEC 60332-1, UL 1581 section 1080 VW-1 CSA FT 1
Halogen free	according to DIN EN 50267-2-1
Product photo	The product photos are not to scale and do not represent detailed images of the respective products.

### Construction

- Jacket color orange RAL 2003

Part-No.	LENZE description*	Length m	Number of conductors/cross-section	Outer Ø ca. mm
<b>For fixed installation</b>				
193900.1000	EWLM-010GM-015*	10.0	(4G1.5+(2×1.5))	12.7
193901.1000	EWLM-010GM-025*	10.0	(4G2.5+(2×1.5))	13.8
193902.1000	EWLM-010GM-040*	10.0	(4G4+(2×1.5))	15.5
193903.1000	EYP-0003-A-0100-M01-A00*	10.0	(4G1.5)	9.5
<b>For use as C-track chains</b>				
193904.1000	EWLM-010GMS-015*	10.0	(4G1.5+(2×1.5))	12.9
193905.1000	EWLM-010GMS-025*	10.0	(4G2.5+(2×1.5))	13.8
193906.1000	EWLM-010GMS-040*	10.0	(4G4+(2×1.5))	14.9

\* LENZE article designations are registered trademarks of LENZE AG, and are for reference purposes only

# Signal cables

## According to LENZE-Standard

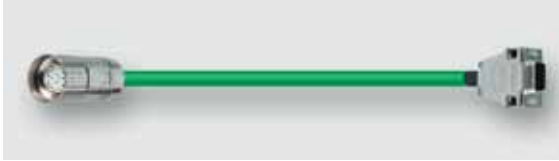

### Application

- LENZE encoder cables

#### For fixed installation

- PVC outer jacket, PVC conductor insulation, flame-retardant, suitable for fixed installation

#### For use as C-track chains

- Due to full PUR jacket and TPE conductor insulation optimally suited for c-tracks, extremely rough operating conditions, aggressive coolants and lubricants

### Properties

- Silicone free
- RoHS-compliant

### Technical data

UL approval	cURus
Nominal voltage	300 V 80 °C
Voltage	
U <sub>0</sub> /U	0.6/1 kV
Insulation resistance	min. 200 MΩ × km
Temperature range	
PVC cable	
moving	-5 °C to +80 °C
fixed	-25 °C to +80 °C
PUR cable	
moving	-25 °C to +80 °C
fixed	-40 °C to +80 °C
Minimum bending radius	
moving	D × 12
fixed	D × 7.5
Burning behavior	Flame-retardant according to VDE 0482 T 265-2, DIN EN 50265/2, IEC 60332-1, UL 1581 section 1080 VW-1 CSA FT 1
Halogen free	according to DIN EN 50267-2-1
Product photo	The product photos are not to scale and do not represent detailed images of the respective products.

### Construction

- Jacket color green RAL 6018

Part-No.	LENZE description*	Length m	Outer Ø ca. mm
<b>Encoder cables for fixed installation</b>			
193920.1000	EWLE-010GM-T*	10.0	9.0
<b>Encoder cables for C-track chains</b>			
193921.1000	EWLE-010GMS-T*	10.0	9.0
<b>Resolver cables for hard wiring</b>			
193910.1000	EWLR-010GM-T*	10.0	9.5
<b>Resolver cables for C-track chains</b>			
193911.1000	EWLR-010GMS-T*	10.0	9.0
193912.1000	EWLR-010ZMS-T*	10.0	9.0
193913.1000	EYF-0020-A-0100-F01-S04*	10.0	9.5

\* LENZE article designations are registered trademarks of LENZE AG, and are for reference purposes only

# Servomotor cables

## According to SEW standard base and extension cables

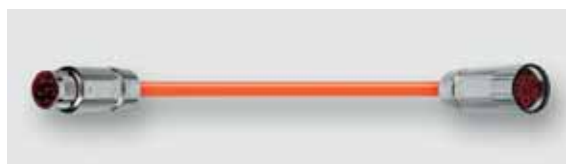
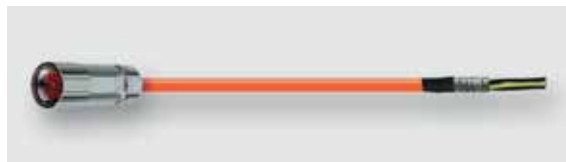

### Application

- Servo cables for SEW drives
- Especially for industrial environments, machines and plants

### For fixed installation

- PVC outer jacket, PVC conductor insulation, flame-retardant, suitable for fixed installation

### For use as C-track chains

- Due to full PUR jacket and TPE conductor insulation optimally suited for C-tracks, extremely rough operating conditions, aggressive coolants and lubricants

### Properties

- Silicone free
- RoHS-compliant

### Technical data

UL approval	cURus
Nominal voltage	1000 V 80 °C
Voltage	
$U_0/U$	0.6/1 kV
Insulation resistance	min. 500 M $\Omega$ × km
Temperature range	
PVC cable	
moving	-5 °C to +80 °C
fixed	-25 °C to +80 °C
PUR cable	
moving	-25 °C to +80 °C
fixed	-40 °C to +80 °C
Minimum bending radius	
moving	D × 10
fixed	D × 7.5
Burning behavior	Flame-retardant according to VDE 0482 T 265-2-1, IEC 60332-1, UL 1581 section 1080 VW-1 CSA FT 1
Halogen free	according to DIN EN 50267-2-1
Product photo	The product photos are not to scale and do not represent detailed images of the respective products.

### Construction

- Jacket color orange RAL 2003

Part-No.	SEW description	Length m	Number of conductors/cross-section	Outer $\varnothing$ ca. mm
<b>Base cables for fixed installation</b>				
193700.1000	0590 4544*	10.0	(4G1.5)	10.1
193741.1000	1335 4345*	10.0	(4G1.5+(3×1.0))	12.3
193712.1000	1332 4853*	10.0	(4G1.5+(3×1.0))	12.3
<b>Base cables for C-track chains</b>				
193702.1000	0590 6245*	10.0	(4G1.5)	10.1
193744.1000	1335 4388*	10.0	(4G1.5+(3×1.0))	12.3
193713.1000	1332 4861*	10.0	(4G1.5+(3×1.0))	12.3
193745.1000	1335 4396*	10.0	(4G2.5+(3×1.0))	13.7
193746.1000	1342 1603*	10.0	(4G4+(3×1.0))	15.3
193736.1000	1335 0234*	10.0	(4G6+(3×1.5))	17.4
193737.1000	1335 0242*	10.0	(4G10+(3×1.5))	20.5
<b>Extensions for C-track chains</b>				
193728.1000	1333 2457*	10.0	(4G1.5)	10.1
193729.1000	1333 2465*	10.0	(4G2.5)	11.6
193730.1000	1333 2473*	10.0	(4G4)	13.2
193738.1000	1335 4221*	10.0	(4G1.5+(3×1.0))	12.3
193739.1000	1335 4248*	10.0	(4G2.5+(3×1.0))	13.7
193740.1000	1335 4337*	10.0	(4G4+(3×1.0))	15.3

\* SEW article designations are registered trademarks of SEW-Eurodrive GmbH & Co KG, and are for reference purposes only

# Servomotor cables

## According to SEW standard base and extension cables

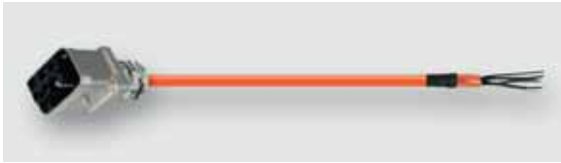

### Application

- Servomotor cables for SEW drives
- Especially for industrial environments, machines and plants

### For fixed installation

- PVC outer jacket, PVC conductor insulation, flame-retardant, suitable for fixed installation

### For use as C-track chains

- Due to full PUR jacket and TPE conductor insulation optimally suited for c-track, extremely rough operating conditions, aggressive coolants and lubricants

### Properties

- Silicone free
- RoHS-compliant

### Technical data

UL approval	cURus
Nominal voltage	1000 V 80 °C
Voltage	
$U_0/U$	0.6/1 kV
Insulation resistance	min. 500 MΩ × km
Temperature range	
PVC cable	
moving	-5 °C to +80 °C
fixed	-25 °C to +80 °C
PUR cable	
moving	-25 °C to +80 °C
fixed	-40 °C to +80 °C
Minimum bending radius	
moving	D × 10
fixed	D × 7.5
Burning behavior	Flame-retardant according to VDE 0482 T 265-2-1, IEC 60332-1, UL 1581 section 1080 VW-1 CSA FT 1
Halogen free	according to DIN EN 50267-2-1
Product photo	The product photos are not to scale and do not represent detailed images of the respective products.

### Construction

- Jacket color orange RAL 2003

Part-No.	SEW description	Length m	Number of conductors/cross-section	Outer Ø ca. mm
<b>Motor base cables for fixed installation</b>				
193764.1000	199 179 5*	10.0	(4G1.5)	10.1
193766.1000	199 181 7*	10.0	(4G2.5)	11.6
193768.1000	199 183 3*	10.0	(4G4)	13.2
193770.1000	199 185 X*	10.0	(4G6)	15.3
193772.1000	199 187 6*	10.0	(4G10)	17.8
<b>Brake motor base cables for fixed installation</b>				
193774.1000	199 189 2*	10.0	(4G1.5+(3×1.0))	12.3
193776.1000	199 191 4*	10.0	(4G2.5+(3×1.0))	13.8
193778.1000	199 193 0*	10.0	(4G4+(3×1.0))	15.3
193780.1000	199 195 7*	10.0	(4G6+(3×1.5))	17.5
193782.1000	199 197 3*	10.0	(4G10+(3×1.5))	20.0
<b>Moro extensions for fixed installation</b>				
193805.1000	199 551 0*	10.0	(4G2.5)	11.6
193807.1000	199 553 7*	10.0	(4G4)	13.2
193809.1000	199 555 3*	10.0	(4G6)	15.3
193813.1000	199 557 X*	10.0	(4G10)	17.8
<b>Brake motor extensions for fixed installation</b>				
193784.1000	199 199 X*	10.0	(4G1.5+(3×1.0))	12.3
193786.1000	199 201 5*	10.0	(4G2.5+(3×1.0))	13.8
193788.1000	199 203 1*	10.0	(4G4+(3×1.0))	15.3
193790.1000	199 205 8*	10.0	(4G6+(3×1.5))	17.5
193792.1000	199 207 4*	10.0	(4G10+(3×1.5))	20.0
<b>Motor base cables for C-tracks</b>				
193765.1000	199 180 9*	10.0	(4G1.5)	10.1
193767.1000	199 182 5*	10.0	(4G2.5)	11.6
193769.1000	199 184 1*	10.0	(4G4)	13.2
193771.1000	199 186 8*	10.0	(4G6)	15.3
193773.1000	199 188 4*	10.0	(4G10)	17.8
<b>Brake motor extensions for C-tracks</b>				
193775.1000	199 190 6*	10.0	(4G1.5+(3×1.0))	12.3
193777.1000	199 192 2*	10.0	(4G2.5+(3×1.0))	13.8
193779.1000	199 194 9*	10.0	(4G4+(3×1.0))	15.3
193781.1000	199 196 5*	10.0	(4G6+(3×1.5))	17.5
193783.1000	199 198 1*	10.0	(4G10+(3×1.5))	20.0
<b>Motor extensions for C-tracks</b>				
193804.1000	199 550 2*	10.0	(4G1.5)	10.1
193806.1000	199 552 9*	10.0	(4G2.5)	11.6
193808.1000	199 554 5*	10.0	(4G4)	13.2
193811.1000	199 556 1*	10.0	(4G6)	15.3
193814.1000	199 558 8*	10.0	(4G10)	17.8
<b>Brake motor extensions for C-tracks</b>				
193785.1000	199 200 7*	10.0	(4G1.5+(3×1.0))	12.3
193787.1000	199 202 3*	10.0	(4G2.5+(3×1.0))	13.8
193789.1000	199 204 X*	10.0	(4G4+(3×1.0))	15.3
193791.1000	199 206 6*	10.0	(4G6+(3×1.5))	17.5
193793.1000	199 208 2*	10.0	(4G10+(3×1.5))	20.0

\* SEW article designations are registered trademarks of SEW-Eurodrive GmbH & Co KG, and are for reference purposes only

# Signal cables

## According to SEW standard

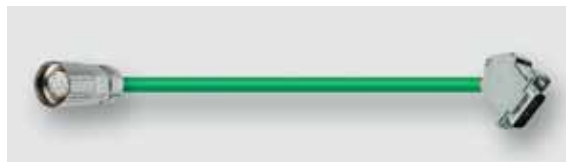

### Application

- SEW resolver and encoder cables
- Especially for industrial environments, machines and plants

### For fixed installation

- PVC outer jacket, PVC conductor insulation, flame-retardant, suitable for fixed installation

### For use as C-track chains

- Due to full PUR jacket and TPE conductor insulation optimally suited for c-tracks, extremely rough operating conditions, aggressive coolants and lubricants

### Properties

- Silicone free
- RoHS-compliant

### Technical data

UL approval	cURus
Nominal voltage	300 V 80 °C
Voltage	
$U_0/U$	0.6/1 kV
Insulation resistance	min. 200 M $\Omega$ × km
Temperature range	
PVC cable	
moving	-5 °C to +80 °C
fixed	-25 °C to +80 °C
PUR cable	
moving	-25 °C to +80 °C
fixed	-40 °C to +80 °C
Minimum bending radius	
moving	D × 12
fixed	D × 7.5
Burning behavior	Flame-retardant according to VDE 0482 T 265-2, DIN EN 50265/2, IEC 60332-1, UL 1581 section 1080 VW-1 CSA FT 1
Halogen free	according to DIN EN 50267-2-1
Product photo	The product photos are not to scale and do not represent detailed images of the respective products.

### Construction

- Jacket color green RAL 6018

Part-No.	SEW description	Length m	Outer $\varnothing$ ca. mm
<b>For fixed installation</b>			
193714.1000	1332 7429*	10.0	8.8
193706.1000	1332 4535*	10.0	9.4
193709.1000	1332 4578*	10.0	9.4
193711.1000	1332 4594*	10.0	8.8
193715.1000	1332 7658*	10.0	9.4
193718.1000	1332 8131*	10.0	8.8
<b>For use as C-track chains</b>			
193708.1000	1332 4551*	10.0	9.4
193707.1000	1332 4543*	10.0	9.4
193710.1000	1332 4586*	10.0	8.8
193716.1000	1332 7666*	10.0	9.4
193717.1000	1332 8123*	10.0	9.4
193794.1000	199 319 4*	10.0	8.8

\* SEW article designations are registered trademarks of SEW-Eurodrive GmbH & Co KG, and are for reference purposes only



# Servo cable assemblies without brake cores for fixed installation

## Acc. to SIEMENS-6FX5002 standard Base cable



### Application

- Base cable for Siemens servo drives
- For flexible applications without continuous flexing
- More cost-effective alternative to the cable chain version 6FX8002

### Properties

- PVC Flame-retardant, self-extinguishing
- Silicone free
- RoHS-compliant

### Technical data

UL approval	cURus
Nominal voltage	1000 V 80 °C
Voltage	
$U_0/U$	0.6/1 kV
Test voltage	4000 V
Insulation resistance	min. 500 MΩ × km
Temperature range	
moving	-5 °C to +80 °C
fixed	-25 °C to +80 °C
Minimum bending radius	
moving	D × 10
fixed	D × 6
Burning behavior	Flame-retardant according to VDE 0482 T 265-2, DIN EN 50265-2, IEC 60332-1, UL 1581 section 1080 VW-1, CSA FT 1
Product photo	The product photos are not to scale and do not represent detailed images of the respective products.

### Construction

- Bare copper wire, multi-strand according to DIN VDE 0295 class 5, IEC 60228 class 5
- Special TPM/PP-conductor insulation, UL certified
- Conductor marking Power conductors black with numbered print U/L1/C/L+, V/L2, W/L3/D/L-
- Ground conductor green/yellow according to DIN EN 50334
- Fleece wrap over cable core
- Braid from tinned copper wire, optical coverage ≥ 85 %
- Jacket color orange RAL 2003

Part-No.	SIEMENS designation	Length m	Number of conductors/ cross-section	Outer Ø ca. mm
<b>SINAMICS, speed-connect/Booksize</b>				
198098.1000	6FX5002-5CN01-1BA0*	10.0	(4G1.5)	8.4
198103.1000	6FX5002-5CN11-1BA0*	10.0	(4G2.5)	10.6
198104.1000	6FX5002-5CN21-1BA0*	10.0	(4G1.5)	8.4
198106.1000	6FX5002-5CN31-1BA0*	10.0	(4G2.5)	10.6
198107.1000	6FX5002-5CN41-1BA0*	10.0	(4G4)	11.5
198108.1000	6FX5002-5CN51-1BA0*	10.0	(4G6)	13.2
198109.1000	6FX5002-5CN61-1BA0*	10.0	(4G10)	16.5
<b>SINAMICS, full thread/Booksize</b>				
198205.1000	6FX5002-5CS01-1BA0*	10.0	(4G1.5)	8.4
198124.1000	6FX5002-5CS11-1BA0*	10.0	(4G2.5)	10.6
198128.1000	6FX5002-5CS13-1BA0*	10.0	(4G10)	16.5
198129.1000	6FX5002-5CS21-1BA0*	10.0	(4G1.5)	8.4
198132.1000	6FX5002-5CS31-1BA0*	10.0	(4G2.5)	10.6
198133.1000	6FX5002-5CS41-1BA0*	10.0	(4G4)	11.5
198136.1000	6FX5002-5CS51-1BA0*	10.0	(4G6)	13.2
198139.1000	6FX5002-5CS61-1BA0*	10.0	(4G10)	16.5
<b>SINAMICS, open end/Booksize</b>				
198123.1000	6FX5002-5CS02-1BA0*	10.0	(4G1.5)	8.4
198126.1000	6FX5002-5CS12-1BA0*	10.0	(4G2.5)	10.6
198321.1000	6FX5002-5CS42-1BA0*	10.0	(4G4)	16.5
198322.1000	6FX5002-5CS52-1BA0*	10.0	(4G6)	14.0
198323.1000	6FX5002-5CS62-1BA0*	10.0	(4G10)	16.5

\* Siemens article designations are registered trademarks of Siemens AG, and are for reference purposes only

# Servo cable assemblies without brake cores for fixed installation

## Acc. to SIEMENS-6FX5002 standard Base cable



### Application

- Base cable for Siemens servo drives
- For flexible applications without continuous flexing
- More cost-effective alternative to the cable chain version 6FX8002

### Properties

- PVC Flame-retardant, self-extinguishing
- Silicone free
- RoHS-compliant

### Technical data

UL approval	cURus
Nominal voltage	1000 V 80 °C
Voltage	
U <sub>0</sub> /U	0.6/1 kV
Test voltage	4000 V
Insulation resistance	min. 500 MΩ × km
Temperature range	
moving	-5 °C to +80 °C
fixed	-25 °C to +80 °C
Minimum bending radius	
moving	D × 10
fixed	D × 6
Burning behavior	Flame-retardant according to VDE 0482 T 265-2, DIN EN 50265-2, IEC 60332-1, UL 1581 section 1080 VW-1, CSA FT 1
Product photo	The product photos are not to scale and do not represent detailed images of the respective products.

### Construction

- Bare copper wire, multi-strand according to DIN VDE 0295 class 5, IEC 60228 class 5
- Special TPM/PP-conductor insulation, UL certified
- Conductor marking Power conductors black with numbered print U/L1/C/L+, V/L2, W/L3/D/L-
- Ground conductor green/yellow according to DIN EN 50334
- Fleece wrap over cable core
- Braid from tinned copper wire, optical coverage ≥ 85 %
- Jacket color orange RAL 2003

Part-No.	SIEMENS designation	Length m	Number of conductors/ cross-section	Outer Ø ca. mm
<b>SIMODRIVE, full thread/open end</b>				
198042.1000	6FX5002-5CA01-1BA0*	10.0	(4G1.5)	8.4
198046.1000	6FX5002-5CA11-1BA0*	10.0	(4G2.5)	10.6
198048.1000	6FX5002-5CA13-1BA0*	10.0	(4G10)	16.5
198051.1000	6FX5002-5CA21-1BA0*	10.0	(4G1.5)	8.4
198052.1000	6FX5002-5CA23-1BA0*	10.0	(4G16)	21.2
198054.1000	6FX5002-5CA31-1BA0*	10.0	(4G2.5)	10.6
198059.1000	6FX5002-5CA41-1BA0*	10.0	(4G4)	11.5
198063.1000	6FX5002-5CA51-1BA0*	10.0	(4G6)	13.2
198066.1000	6FX5002-5CA61-1BA0*	10.0	(4G10)	16.5
<b>SINAMICS, full thread/open end</b>				
198068.1000	6FX5002-5CG01-1BA0*	10.0	(4G1.5)	8.4
198071.1000	6FX5002-5CG11-1BA0*	10.0	(4G2.5)	10.6
198292.1000	6FX5002-5CG13-1BA0*	10.0	(4G10)	16.5
198073.1000	6FX5002-5CG21-1BA0*	10.0	(4G1.5)	8.4
198293.1000	6FX5002-5CG23-1BA0*	10.0	(4G16)	21.2
198078.1000	6FX5002-5CG31-1BA0*	10.0	(4G2.5)	10.6
198083.1000	6FX5002-5CG41-1BA0*	10.0	(4G4)	11.5
198088.1000	6FX5002-5CG51-1BA0*	10.0	(4G6)	14.0
198093.1000	6FX5002-5CG61-1BA0*	10.0	(4G10)	16.5
198273.1000	6FX5002-5CS14-1BA0*	10.0	(4G10)	16.5
198294.1000	6FX5002-5CS23-1BA0*	10.0	(4G16)	21.2
198299.1000	6FX5002-5CS54-1BA0*	10.0	(4G6)	14.0
198309.1000	6FX5002-5CS64-1BA0*	10.0	(4G10)	16.5
198353.1000	6FX5002-5CG32-1BA0*	10.0	(4G2.5)	10.6

\* Siemens article designations are registered trademarks of Siemens AG, and are for reference purposes only

# Servo cable assemblies with brake cores for fixed installation

## Acc. to SIEMENS-6FX5002 standard Base cable



### Application

- Base cable for Siemens servo drives
- For flexible applications without continuous flexing
- More cost-effective alternative to the cable chain version 6FX8002

### Properties

- PVC Flame-retardant, self-extinguishing
- Silicone free
- RoHS-compliant

### Technical data

UL approval	cURus
Nominal voltage	1000 V 80 °C
Voltage	
$U_0/U$	0.6/1 kV
Test voltage	4000 V
Insulation resistance	min. 500 MΩ × km
Temperature range	
moving	-5 °C to +80 °C
fixed	-25 °C to +80 °C
Minimum bending radius	
moving	D × 10
fixed	D × 6
Burning behavior	Flame-retardant according to VDE 0482 T 265-2, DIN EN 50265-2, IEC 60332-1, UL 1581 section 1080 VW-1, CSA FT 1
Product photo	The product photos are not to scale and do not represent detailed images of the respective products.

### Construction

- Bare copper wire, multi-strand according to DIN VDE 0295 class 5, IEC 60228 class 5
- Special TPM/PP-conductor insulation, UL certified
- Conductor marking Power conductors black with numbered print U/L1/C/L+, V/L2, W/L3/D/L-
- Ground conductor green/yellow according to DIN EN 50334
- Signal conductor: white/black (1 pair)
- Fleece wrap over cable core
- Braid from tinned copper wire, optical coverage ≥ 85 %
- Jacket color orange RAL 2003

Part-No.	SIEMENS designation	Length m	Number of conductors/cross-section	Outer Ø ca. mm
<b>SINAMICS, speed-connect/Booksize</b>				
198340.1000	6FX5002-5DN01-1BA0*	10.0	(4G1.5+(2×1.5))	11.6
198341.1000	6FX5002-5DN11-1BA0*	10.0	(4G2.5+(2×1.5))	13.0
198342.1000	6FX5002-5DN21-1BA0*	10.0	(4G1.5+(2×1.5))	11.6
198343.1000	6FX5002-5DN31-1BA0*	10.0	(4G2.5+(2×1.5))	13.0
198344.1000	6FX5002-5DN41-1BA0*	10.0	(4G4+(2×1.5))	14.0
198345.1000	6FX5002-5DN51-1BA0*	10.0	(4G6+(2×1.5))	15.8
198346.1000	6FX5002-5DN61-1BA0*	10.0	(4G10+(2×1.5))	18.5
<b>SINAMICS, full thread/Booksize</b>				
198320.1000	6FX5002-5DS01-1BA0*	10.0	(4G1.5+(2×1.5))	11.6
198325.1000	6FX5002-5DS11-1BA0*	10.0	(4G2.5+(2×1.5))	13.0
198176.1000	6FX5002-5DS13-1BA0*	10.0	(4G10+(2×1.5))	18.5
198177.1000	6FX5002-5DS21-1BA0*	10.0	(4G1.5+(2×1.5))	11.6
198245.1000	6FX5002-5DS31-1BA0*	10.0	(4G2.5+(2×1.5))	13.0
198178.1000	6FX5002-5DS41-1BA0*	10.0	(4G4+(2×1.5))	14.0
198179.1000	6FX5002-5DS51-1BA0*	10.0	(4G6+(2×1.5))	15.8
198182.1000	6FX5002-5DS61-1BA0*	10.0	(4G10+(2×1.5))	18.5

\* Siemens article designations are registered trademarks of Siemens AG, and are for reference purposes only

# Servo cable assemblies with brake cores for fixed installation

## Acc. to SIEMENS-6FX5002 standard Base cable



### Application

- Base cable for Siemens servo drives
- For flexible applications without continuous flexing
- More cost-effective alternative to the cable chain version 6FX8002

### Properties

- PVC Flame-retardant, self-extinguishing
- Silicone free
- RoHS-compliant

### Technical data

UL approval	cURus
Nominal voltage	1000 V 80 °C
Voltage	
U <sub>0</sub> /U	0.6/1 kV
Test voltage	4000 V
Insulation resistance	min. 500 MΩ × km
Temperature range	
moving	-5 °C to +70 °C
fixed	-25 °C to +70 °C
Minimum bending radius	
moving	D × 10
fixed	D × 6
Burning behavior	Flame-retardant according to VDE 0482 T 265-2, DIN EN 50265-2, IEC 60332-1, UL 1581 section 1080 VW-1, CSA FT 1
Product photo	The product photos are not to scale and do not represent detailed images of the respective products.

### Construction

- Bare copper wire, multi-strand according to DIN VDE 0295 class 5, IEC 60228 class 5
- Special TPM/PP-conductor insulation, UL certified
- Conductor marking Power conductors black with numbered print U/L1/C/L+, V/L2, W/L3/D/L-
- Ground conductor green/yellow according to DIN EN 50334
- Control pair color-coded (bk, wh)
- Control pair with braided shield and foil tape
- Fleece wrap over cable core
- Braid from tinned copper wire, optical coverage ≥ 85 %
- Jacket color orange RAL 2003

Part-No.	SIEMENS designation	Length m	Number of conductors/cross-section	Outer Ø ca. mm
<b>SIMODRIVE, full thread/open end</b>				
198461.1000	6FX5002-5DA01-1BA0*	10.0	(4G1.5+(2×1.5))	11.6
198481.1000	6FX5002-5DA11-1BA0*	10.0	(4G2.5+(2×1.5))	13.0
198146.1000	6FX5002-5DA13-1BA0*	10.0	(4G10+(2×1.5))	18.5
198501.1000	6FX5002-5DA21-1BA0*	10.0	(4G1.5+(2×1.5))	11.6
198871.1000	6FX5002-5DA23-1BA0*	10.0	(4G16+(2×1.5))	23.6
198531.1000	6FX5002-5DA31-1BA0*	10.0	(4G2.5+(2×1.5))	13.0
198881.1000	6FX5002-5DA33-1BA0*	10.0	(4G25+(2×1.5))	28.5
198561.1000	6FX5002-5DA41-1BA0*	10.0	(4G4+(2×1.5))	14.0
198571.1000	6FX5002-5DA51-1BA0*	10.0	(4G6+(2×1.5))	15.8
198581.1000	6FX5002-5DA61-1BA0*	10.0	(4G10+(2×1.5))	18.5
<b>SINAMICS, full thread/open end</b>				
198076.1000	6FX5002-5DG01-1BA0*	10.0	(4G1.5+(2×1.5))	11.6
198086.1000	6FX5002-5DG11-1BA0*	10.0	(4G2.5+(2×1.5))	13.0
198287.1000	6FX5002-5DG13-1BA0*	10.0	(4G10+(2×1.5))	18.5
198081.1000	6FX5002-5DG21-1BA0*	10.0	(4G1.5+(2×1.5))	11.6
198288.1000	6FX5002-5DG23-1BA0*	10.0	(4G16+(2×1.5))	23.6
198091.1000	6FX5002-5DG31-1BA0*	10.0	(4G2.5+(2×1.5))	13.0
198289.1000	6FX5002-5DG33-1BA0*	10.0	(4G25+(2×1.5))	28.6
198096.1000	6FX5002-5DG41-1BA0*	10.0	(4G4+(2×1.5))	14.0
198101.1000	6FX5002-5DG51-1BA0*	10.0	(4G6+(2×1.5))	15.8
198116.1000	6FX5002-5DG61-1BA0*	10.0	(4G10+(2×1.5))	18.5
198296.1000	6FX5002-5DS14-1BA0*	10.0	(4G10+(2×1.5))	18.5
198264.1000	6FX5002-5DS23-1BA0*	10.0	(4G16+(2×1.5))	23.6
198297.1000	6FX5002-5DS54-1BA0*	10.0	(4G6+(2×1.5))	15.8
198298.1000	6FX5002-5DS64-1BA0*	10.0	(4G10+(2×1.5))	18.5

\* Siemens article designations are registered trademarks of Siemens AG, and are for reference purposes only

# Servo cable assemblies without brake cores for fixed installation

## Acc. to SIEMENS-6FX5002 standard Extension



### Application

- Base cable for Siemens servo drives
- For flexible applications without continuous flexing
- More cost-effective alternative to the cable chain version 6FX8002

### Properties

- PVC Flame-retardant, self-extinguishing
- Silicone free
- RoHS-compliant

### Notes:

- The extension can also be used for **SPEED-CONNECT** plug connection, for this the O-ring must be removed on the outer thread. This does not affect the tightness of the plug connection.

### Technical data

UL approval	cURus
Nominal voltage	1000 V 80 °C
Voltage	
$U_0/U$	0.6/1 kV
Test voltage	4000 V
Insulation resistance	min. 500 MΩ × km
Temperature range	
moving	-5 °C to +80 °C
fixed	-25 °C to +80 °C
Minimum bending radius	
moving	D × 10
fixed	D × 6
Burning behavior	Flame-retardant according to VDE 0482 T 265-2, DIN EN 50265-2, IEC 60332-1, UL 1581 section 1080 VW-1, CSA FT 1
Product photo	The product photos are not to scale and do not represent detailed images of the respective products.

### Construction

- Bare copper wire, multi-strand according to DIN VDE 0295 class 5, IEC 60228 class 5
- Special TPM/PP-conductor insulation, UL certified
- Conductor marking Power conductors black with numbered print U/L1/C/L+, V/L2, W/L3/D/L-
- Ground conductor green/yellow according to DIN EN 50334
- Fleece wrap over cable core
- Braid from tinned copper wire, optical coverage ≥ 85 %
- Jacket color orange RAL 2003

Part-No.	SIEMENS designation	Length m	Number of conductors/ cross-section	Outer Ø ca. mm
<b>SINAMICS/SIMODRIVE, full thread</b>				
198044.1000	6FX5002-5CA05-1BA0*	10.0	(4G1.5)	8.4
198049.1000	6FX5002-5CA15-1BA0*	10.0	(4G2.5)	10.6
198053.1000	6FX5002-5CA28-1BA0*	10.0	(4G1.5)	8.4
198058.1000	6FX5002-5CA38-1BA0*	10.0	(4G2.5)	10.6
198062.1000	6FX5002-5CA48-1BA0*	10.0	(4G4)	11.5
198064.1000	6FX5002-5CA58-1BA0*	10.0	(4G6)	13.2
198067.1000	6FX5002-5CA68-1BA0*	10.0	(4G10)	16.5
198143.1000	6FX5002-5CX18-1BA0*	10.0	(4G10)	16.5
198144.1000	6FX5002-5CX28-1BA0*	10.0	(4G16)	21.2

\* Siemens article designations are registered trademarks of Siemens AG, and are for reference purposes only

# Servo cable assemblies with brake cores for fixed installation

## Acc. to SIEMENS-6FX5002 standard Extension



### Application

- Extension, for Siemens servo drives
- For flexible application without continuous flexing
- Cost-effective alternative to the c-tracks suitable 6FX8002 version

### Properties

- PVC Flame-retardant, self-extinguishing
- Silicone free
- RoHS-compliant

### Notes:

- The extension can also be used for **SPEED-CONNECT** plug connection, for this the O-ring must be removed on the outer thread. This does not affect the tightness of the plug connection.

### Technical data

UL approval	cURus
Nominal voltage	1000 V 80 °C
Voltage	
$U_0/U$	0.6/1 kV
Test voltage	4000 V
Insulation resistance	min. 500 M $\Omega$ × km
Temperature range	
moving	-5 °C to +80 °C
fixed	-25 °C to +80 °C
Minimum bending radius	
moving	D × 10
fixed	D × 6
Burning behavior	Flame-retardant according to VDE 0482 T 265-2, DIN EN 50265-2, IEC 60332-1, UL 1581 section 1080 VW-1, CSA FT 1
Product photo	The product photos are not to scale and do not represent detailed images of the respective products.

### Construction

- Bare copper wire, multi-strand according to DIN VDE 0295 class 5, IEC 60228 class 5
- Special TPM/PP-conductor insulation, UL certified
- Conductor marking Power conductors black with numbered print U/L1/C/L+, V/L2, W/L3/D/L-
- Ground conductor green/yellow according to DIN EN 50334
- Control pair color-coded (bk, wh)
- Control pair with braided shield and foil tape
- Fleece wrap over cable core
- Braid from tinned copper wire, optical coverage  $\geq$  85 %
- Jacket color orange RAL 2003

Part-No.	SIEMENS designation	Length m	Number of conductors/cross-section	Outer $\varnothing$ ca. mm
<b>SINAMICS/SIMODRIVE, full thread</b>				
198731.1000	6FX5002-5DA05-1BA0*	10.0	(4G1.5+(2×1.5))	11.6
198991.1000	6FX5002-5DA15-1BA0*	10.0	(4G2.5+(2×1.5))	13.0
198791.1000	6FX5002-5DA28-1BA0*	10.0	(4G1.5+(2×1.5))	11.6
198801.1000	6FX5002-5DA38-1BA0*	10.0	(4G2.5+(2×1.5))	13.0
198006.1000	6FX5002-5DA48-1BA0*	10.0	(4G4+(2×1.5))	14.0
198011.1000	6FX5002-5DA58-1BA0*	10.0	(4G6+(2×1.5))	15.8
198026.1000	6FX5002-5DA68-1BA0*	10.0	(4G10+(2×1.5))	18.5
198183.1000	6FX5002-5DX18-1BA0*	10.0	(4G10+(2×1.5))	18.5
198184.1000	6FX5002-5DX28-1BA0*	10.0	(4G16+(2×1.5))	23.6
198186.1000	6FX5002-5DX38-1BA0*	10.0	(4G25+(2×1.5))	28.5

\* Siemens article designations are registered trademarks of Siemens AG, and are for reference purposes only

# Signal cables for fixed installation

## According to SIEMENS-6FX5002 standard Base cable DRIVE-CLIQ®



### Application

- Resolver cable
- For flexible application without continuous flexing
- Cost-effective alternative to the c-tracks suitable 6FX8002 version

### Properties

- Silicone free
- RoHS-compliant

### Technical data

UL approval	cURus
Nominal voltage	30 V 80 °C
Test voltage	500 V
Insulation resistance	min. 20 MΩ × km
Temperature range	
moving	-5 °C to +80 °C
fixed	-25 °C to +80 °C
Minimum bending radius	
moving	D × 15
fixed	D × 7.5
Burning behavior	Flame-retardant according to VDE 0482 T 265-2, DIN EN 50265-2, IEC 60332-1
Product photo	The product photos are not to scale and do not represent detailed images of the respective products.

Part-No.	SIEMENS designation	Length m	Outer Ø ca. mm
<b>SINAMICS</b>			
198036.1000	6FX5002-2DC00-1BA0*	10.0	7.2
198037.1000	6FX5002-2DC10-1BA0*	10.0	7.2
198038.1000	6FX5002-2DC20-1BA0*	10.0	7.2

### Construction

- Bare copper wire, multi-strand according to DIN VDE 0295 class 5, IEC 60228 class 5
- Special thermoplastic conductor insulation
- Color coded conductor
- Ground conductor green/yellow according to DIN EN 50334
- Braid from tinned copper wire, optical coverage ≥ 85 %
- Jacket special PVC TM2 according to HD21.1, matte, adhesion-free surface
- Jacket color green RAL 6018

\* Siemens article designations are registered trademarks of Siemens AG, and are for reference purposes only

# Servo cable assemblies without brake cores for C-tracks

## Acc. to SIEMENS-6FX8002 standard Base cable



### Application

- Base cable DRIVE-CLIQ<sup>®</sup>, for SIEMENS SERVO drives
- Due to full PUR jacket and TPE conductor insulation optimally suited for c-tracks, extremely rough operating conditions, aggressive coolants and lubricants
- Especially for industrial environments, machines and plants

### Properties

- Silicone free
- RoHS-compliant

### Technical data

UL approval	cURus
Nominal voltage	1000 V 80 °C
Voltage	
U <sub>0</sub> /U	0.6/1 kV
Test voltage	4000 V
Insulation resistance	min. 500 MΩ × km
Temperature range	
moving	-25 °C to +80 °C
fixed	-40 °C to +80 °C
Minimum bending radius	
moving	D × 10
fixed	D × 6
Burning behavior	Flame-retardant according to VDE 0482 T 265-2, DIN EN 50265-2, IEC 60332-1, UL 1581 section 1080 VW-1, CSA FT 1
Halogen free	according to DIN EN 50267-2-1
Product photo	The product photos are not to scale and do not represent detailed images of the respective products.

### Construction

- Bare copper wire, finely stranded according to DIN VDE 0295 class 6, IEC 60228 class 6
- Special TPE/HGI conductor insulation, UL qualified
- Conductor marking Power conductors black with numbered print U/L1/C/L+, V/L2, W/L3/D/L-
- Ground conductor green/yellow according to DIN EN 50334
- Conductors cabled in layers without mechanical stress, layer pitch optimised
- Fleece wrap over cable core
- Braid from tinned copper wire, optical coverage ≥ 85 %
- Full polyurethane jacket, matte, adhesion-free surface
- Jacket color orange RAL 2003

Part-No.	SIEMENS designation	Length m	Number of conductors/ cross-section	Outer Ø ca. mm
<b>SINAMICS, speed-connect/Booksize</b>				
198326.1000	6FX8002-5CN01-1BA0*	10.0	(4G1.5)	8.6
198327.1000	6FX8002-5CN11-1BA0*	10.0	(4G2.5)	10.8
198328.1000	6FX8002-5CN21-1BA0*	10.0	(4G1.5)	8.6
198329.1000	6FX8002-5CN31-1BA0*	10.0	(4G2.5)	10.8
198330.1000	6FX8002-5CN41-1BA0*	10.0	(4G4)	12.2
198331.1000	6FX8002-5CN51-1BA0*	10.0	(4G6)	14.0
198332.1000	6FX8002-5CN61-1BA0*	10.0	(4G10)	17.6
<b>SINAMICS, full thread/Booksize</b>				
198300.1000	6FX8002-5CS01-1BA0*	10.0	(4G1.5)	8.6
198302.1000	6FX8002-5CS11-1BA0*	10.0	(4G2.5)	10.8
198214.1000	6FX8002-5CS13-1BA0*	10.0	(4G10)	17.6
198304.1000	6FX8002-5CS21-1BA0*	10.0	(4G1.5)	8.6
198305.1000	6FX8002-5CS31-1BA0*	10.0	(4G2.5)	10.8
198317.1000	6FX8002-5CS41-1BA0*	10.0	(4G4)	12.2
198318.1000	6FX8002-5CS51-1BA0*	10.0	(4G6)	14.0
198319.1000	6FX8002-5CS61-1BA0*	10.0	(4G10)	17.6
<b>SINAMICS, open end/Booksize</b>				
198301.1000	6FX8002-5CS02-1BA0*	10.0	(4G1.5)	8.6
198303.1000	6FX8002-5CS12-1BA0*	10.0	(4G2.5)	10.6
198306.1000	6FX8002-5CS42-1BA0*	10.0	(4G4)	12.2
198307.1000	6FX8002-5CS52-1BA0*	10.0	(4G6)	14.0
198308.1000	6FX8002-5CS62-1BA0*	10.0	(4G10)	17.6

\* Siemens article designations are registered trademarks of Siemens AG, and are for reference purposes only



# Servo cable assemblies without brake cores for C-tracks

## Acc. to SIEMENS-6FX8002 standard Base cable



### Application

- Base cable, for Siemens servo drives
- Due to full PUR jacket and TPE conductor insulation optimally suited for c-tracks, extremely rough operating conditions, aggressive coolants and lubricants

### Properties

- Silicone free
- RoHS-compliant

### Technical data

UL approval	cURus
Nominal voltage	1000 V 80 °C
Voltage	
$U_0/U$	0.6/1 kV
Test voltage	4000 V
Insulation resistance	min. 500 MΩ × km
Temperature range	
moving	-25 °C to +80 °C
fixed	-40 °C to +80 °C
Minimum bending radius	
moving	D × 10
fixed	D × 6
Burning behavior	Flame-retardant according to VDE 0482 T 265-2, DIN EN 50265-2, IEC 60332-1, UL 1581 section 1080 VW-1, CSA FT 1
Halogen free	according to DIN EN 50267-2-1
Product photo	The product photos are not to scale and do not represent detailed images of the respective products.

Part-No.	SIEMENS designation	Length m	Number of conductors/ cross-section	Outer Ø ca. mm
<b>SIMODRIVE, full thread/open end</b>				
198360.1000	6FX8002-5CA01-1BA0*	10.0	(4G1.5)	8.6
198380.1000	6FX8002-5CA11-1BA0*	10.0	(4G2.5)	10.8
198845.1000	6FX8002-5CA13-1BA0*	10.0	(4G10)	17.6
198400.1000	6FX8002-5CA21-1BA0*	10.0	(4G1.5)	8.6
198810.1000	6FX8002-5CA23-1BA0*	10.0	(4G16)	21.2
198410.1000	6FX8002-5CA31-1BA0*	10.0	(4G2.5)	10.8
198430.1000	6FX8002-5CA41-1BA0*	10.0	(4G4)	12.2
198440.1000	6FX8002-5CA51-1BA0*	10.0	(4G6)	14.0
198450.1000	6FX8002-5CA61-1BA0*	10.0	(4G10)	17.6
<b>SINAMICS, full thread/open end</b>				
198950.1000	6FX8002-5CG01-1BA0*	10.0	(4G1.5)	8.6
198040.1000	6FX8002-5CG11-1BA0*	10.0	(4G2.5)	10.8
198283.1000	6FX8002-5CG13-1BA0*	10.0	(4G10)	17.6
198035.1000	6FX8002-5CG21-1BA0*	10.0	(4G1.5)	8.6
198803.1000	6FX8002-5CG23-1BA0*	10.0	(4G16)	21.2
198045.1000	6FX8002-5CG31-1BA0*	10.0	(4G2.5)	10.8
198050.1000	6FX8002-5CG41-1BA0*	10.0	(4G4)	12.2
198055.1000	6FX8002-5CG51-1BA0*	10.0	(4G6)	14.0
198060.1000	6FX8002-5CG61-1BA0*	10.0	(4G10)	17.6
198284.1000	6FX8002-5CS14-1BA0*	10.0	(4G10)	17.6
198285.1000	6FX8002-5CS23-1BA0*	10.0	(4G16)	21.2
198980.1000	6FX8002-5CS54-1BA0*	10.0	(4G6)	14.0
198286.1000	6FX8002-5CS64-1BA0*	10.0	(4G10)	17.6
198198.1000	6FX8002-5CG32-1BA0*	10.0	(4G2.5)	10.8

### Construction

- Bare copper wire, finely stranded according to DIN VDE 0295 class 6, IEC 60228 class 6
- Special TPE/HGI conductor insulation, UL qualified
- Conductor marking Power conductors black with numbered print U/L1/C/L+, V/L2, W/L3/D/L-
- Ground conductor green/yellow according to DIN EN 50334
- Conductors cabled in layers without mechanical stress, layer pitch optimised
- Braid from tinned copper wire, optical coverage ≥ 85 %
- Full polyurethane jacket, matte, adhesion-free surface
- Jacket color orange RAL 2003

\* Siemens article designations are registered trademarks of Siemens AG, and are for reference purposes only

# Servo cable assemblies with brake cores for C-tracks

## Acc. to SIEMENS-6FX8002 standard Base cable



### Application

- Base cable for Siemens servo drives
- Full PUR jacket and TPE conductor insulation optimally suited for c-tracks, extremely rough operating conditions, aggressive coolants and lubricants
- Especially for industrial environments, machines and plants

### Properties

- Silicone free
- RoHS-compliant

### Technical data

UL approval	cURus
Nominal voltage	1000 V 80 °C
Voltage	
$U_0/U$	0.6/1 kV
Test voltage	4000 V
Insulation resistance	min. 500 MΩ × km
Temperature range	
moving	-25 °C to +80 °C
fixed	-40 °C to +80 °C
Minimum bending radius	
moving	D × 10
fixed	D × 6
Burning behavior	Flame-retardant according to VDE 0482 T 265-2, DIN EN 50265-2, IEC 60332-1, UL 1581 section 1080 VW-1, CSA FT 1
Halogen free	according to DIN EN 50267-2-1, EN 60684-2
Product photo	The product photos are not to scale and do not represent detailed images of the respective products.

Part-No.	SIEMENS designation	Length m	Number of conductors/cross-section	Outer Ø ca. mm
<b>SINAMICS, speed-connect/Booksize</b>				
198333.1000	6FX8002-5DN01-1BA0*	10.0	(4G1.5+(2×1.5))	11.4
198334.1000	6FX8002-5DN11-1BA0*	10.0	(4G2.5+(2×1.5))	12.9
198335.1000	6FX8002-5DN21-1BA0*	10.0	(4G1.5+(2×1.5))	11.4
198336.1000	6FX8002-5DN31-1BA0*	10.0	(4G2.5+(2×1.5))	12.9
198337.1000	6FX8002-5DN41-1BA0*	10.0	(4G4+(2×1.5))	14.5
198338.1000	6FX8002-5DN51-1BA0*	10.0	(4G6+(2×1.5))	16.1
198339.1000	6FX8002-5DN61-1BA0*	10.0	(4G10+(2×1.5))	19.5
<b>SINAMICS, full thread/Booksize</b>				
198310.1000	6FX8002-5DS01-1BA0*	10.0	(4G1.5+(2×1.5))	11.4
198311.1000	6FX8002-5DS11-1BA0*	10.0	(4G2.5+(2×1.5))	12.9
198312.1000	6FX8002-5DS21-1BA0*	10.0	(4G1.5+(2×1.5))	11.4
198313.1000	6FX8002-5DS31-1BA0*	10.0	(4G2.5+(2×1.5))	12.9
198314.1000	6FX8002-5DS41-1BA0*	10.0	(4G4+(2×1.5))	14.5
198315.1000	6FX8002-5DS51-1BA0*	10.0	(4G6+(2×1.5))	16.1
198316.1000	6FX8002-5DS61-1BA0*	10.0	(4G10+(2×1.5))	19.5
198247.1000	6FX8002-5DS13-1BA0*	10.0	(4G10+(2×1.5))	19.5

### Construction

- Bare copper wire, finely stranded according to DIN VDE 0295 class 6, IEC 60228 class 6
- Special TPE/HGI conductor insulation, UL certified
- Conductor marking Power conductors black with numbered print U/L1/C/L+, V/L2, W/L3/D/L-
- Ground conductor green/yellow according to DIN EN 50334
- Control pair color-coded (bk, wh)
- Control pair with braided shield and foil tape
- Conductors cabled in layers without mechanical stress, layer pitch optimised
- Fleece wrap over cable core
- Braid from tinned copper wire, optical coverage ≥ 85 %
- Outer jacket Full polyurethane jacket, matte, adhesion-free surface
- Jacket color orange RAL 2003

\* Siemens article designations are registered trademarks of Siemens AG, and are for reference purposes only

# Servo cable assemblies with brake cores for C-tracks

## Acc. to SIEMENS-6FX8002 standard Base cable



### Application

- Base cable, for Siemens servo drives
- Due to full PUR jacket and TPE conductor insulation optimally suited for c-tracks, extremely rough operating conditions, aggressive coolants and lubricants
- Especially for industrial environments, machines and plants

### Properties

- Silicone free
- RoHS-compliant

### Technical data

UL approval	cURus
Nominal voltage	1000 V 80 °C
Voltage	
U <sub>0</sub> /U	0.6/1 kV
Test voltage	4000 V
Insulation resistance	min. 500 MΩ × km
Temperature range	
moving	-25 °C to +80 °C
fixed	-40 °C to +80 °C
Minimum bending radius	
moving	D × 10
fixed	D × 6
Burning behavior	Flame-retardant according to VDE 0482 T 265-2, DIN EN 50265-2, IEC 60332-1, UL 1581 section 1080 VW-1, CSA FT 1
Halogen free	according to DIN EN 50267-2-1, EN 60684-2
Product photo	The product photos are not to scale and do not represent detailed images of the respective products.

### Construction

- Bare copper wire, finely stranded according to DIN VDE 0295 class 6, IEC 60228 class 6
- Special TPE/HGI conductor insulation, UL certified
- Conductor marking Power conductors black with numbered print U/L1/C/L+, V/L2, W/L3/D/L-
- Ground conductor green/yellow according to DIN EN 50334
- Control pair color-coded (bk, wh)
- Control pair with braided shield and foil tape
- Conductors cabled in layers without mechanical stress, layer pitch optimised
- Fleece wrap over cable core
- Braid from tinned copper wire, optical coverage ≥ 85 %
- Outer jacket Full polyurethane jacket, matte, adhesion-free surface
- Jacket color orange RAL 2003

Part-No.	SIEMENS designation	Length m	Number of conductors/cross-section	Outer Ø ca. mm
<b>SIMODRIVE, full thread/open end</b>				
198460.1000	6FX8002-5DA01-1BA0*	10.0	(4G1.5+(2×1.5))	11.4
198480.1000	6FX8002-5DA11-1BA0*	10.0	(4G2.5+(2×1.5))	12.9
198840.1000	6FX8002-5DA13-1BA0*	10.0	(4G10+(2×1.5))	19.5
198500.1000	6FX8002-5DA21-1BA0*	10.0	(4G1.5+(2×1.5))	11.4
198870.1000	6FX8002-5DA23-1BA0*	10.0	(4G16+(2×1.5))	23.6
198530.1000	6FX8002-5DA31-1BA0*	10.0	(4G2.5+(2×1.5))	12.9
198880.1000	6FX8002-5DA33-1BA0*	10.0	(4G25+(2×1.5))	28.5
198560.1000	6FX8002-5DA41-1BA0*	10.0	(4G4+(2×1.5))	14.5
198349.1000	6FX8002-5DA43-1BA0*	10.0	(4G35+(2×1.5))	32.0
198570.1000	6FX8002-5DA51-1BA0*	10.0	(4G6+(2×1.5))	16.1
198580.1000	6FX8002-5DA61-1BA0*	10.0	(4G10+(2×1.5))	19.5
<b>SINAMICS, full thread/open end</b>				
198075.1000	6FX8002-5DG01-1BA0*	10.0	(4G1.5+(2×1.5))	11.4
198085.1000	6FX8002-5DG11-1BA0*	10.0	(4G2.5+(2×1.5))	12.9
198275.1000	6FX8002-5DG13-1BA0*	10.0	(4G10+(2×1.5))	19.5
198080.1000	6FX8002-5DG21-1BA0*	10.0	(4G1.5+(2×1.5))	11.4
198276.1000	6FX8002-5DG23-1BA0*	10.0	(4G16+(2×1.5))	23.6
198090.1000	6FX8002-5DG31-1BA0*	10.0	(4G2.5+(2×1.5))	12.9
198277.1000	6FX8002-5DG33-1BA0*	10.0	(4G25+(2×1.5))	28.5
198095.1000	6FX8002-5DG41-1BA0*	10.0	(4G4+(2×1.5))	14.5
198278.1000	6FX8002-5DG43-1BA0*	10.0	(4G35+(2×1.5))	32.0
198100.1000	6FX8002-5DG51-1BA0*	10.0	(4G6+(2×1.5))	16.1
198279.1000	6FX8002-5DG53-1BA0*	10.0	(4G50+(2×1.5))	37.3
198115.1000	6FX8002-5DG61-1BA0*	10.0	(4G10+(2×1.5))	19.5
198263.1000	6FX8002-5DS14-1BA0*	10.0	(4G10+(2×1.5))	19.5
198267.1000	6FX8002-5DS23-1BA0*	10.0	(4G16+(2×1.5))	23.6
198259.1000	6FX8002-5DS54-1BA0*	10.0	(4G6+(2×1.5))	16.1
198262.1000	6FX8002-5DS64-1BA0*	10.0	(4G10+(2×1.5))	19.5

\* Siemens article designations are registered trademarks of Siemens AG, and are for reference purposes only

# Servo cable assemblies without brake cores for C-tracks

## Acc. to SIEMENS-6FX8002 standard Extension



### Application

- Extension, for Siemens servo drives
- Due to full PUR jacket and TPE conductor insulation optimally suited for c-tracks, extremely rough operating conditions, aggressive coolants and lubricants

### Properties

- Silicone free
- RoHS-compliant

### Notes:

- The extension can also be used for **SPEED-CONNECT** plug connection, for this the O-ring must be removed on the outer thread. This does not affect the tightness of the plug connection.

### Technical data

UL approval	cURus
Nominal voltage	1000 V 80 °C
Voltage	
$U_0/U$	0.6/1 kV
Test voltage	4000 V
Insulation resistance	min. 500 M $\Omega$ × km
Temperature range	
moving	-25 °C to +80 °C
fixed	-40 °C to +80 °C
Minimum bending radius	
moving	D × 10
fixed	D × 6
Burning behavior	Flame-retardant according to VDE 0482 T 265-2, DIN EN 50265-2, IEC 60332-1, UL 1581 section 1080 VW-1, CSA FT 1
Halogen free	according to DIN EN 50267-2-1, EN 60684-2
Product photo	The product photos are not to scale and do not represent detailed images of the respective products.

### Construction

- Bare copper wire, finely stranded according to DIN VDE 0295 class 6, IEC 60228 class 6
- Special TPE/HGI conductor insulation, UL certified
- Conductor marking Power conductors black with numbered print U/L1/C/L+, V/L2, W/L3/D/L-
- Ground conductor green/yellow according to DIN EN 50334
- Conductors cabled in layers without mechanical stress, optimised lay pitch
- Fleece wrap over cable core
- Braid from tinned copper wire, optical coverage ≥ 85 %
- Outer jacket Full polyurethane jacket, matte, adhesion-free surface
- Jacket color orange RAL 2003

Part-No.	SIEMENS designation	Length m	Number of conductors/cross-section	Outer Ø ca. mm
<b>SINAMICS/SIMODRIVE, full thread</b>				
198820.1000	6FX8002-5CA05-1BA0*	10.0	(4G1.5)	8.6
198985.1000	6FX8002-5CA15-1BA0*	10.0	(4G2.5)	10.8
198765.1000	6FX8002-5CA28-1BA0*	10.0	(4G1.5)	8.6
198995.1000	6FX8002-5CA38-1BA0*	10.0	(4G2.5)	10.8
198015.1000	6FX8002-5CA48-1BA0*	10.0	(4G4)	12.2
198020.1000	6FX8002-5CA58-1BA0*	10.0	(4G6)	14.0
198030.1000	6FX8002-5CA68-1BA0*	10.0	(4G10)	17.6
198216.1000	6FX8002-5CX18-1BA0*	10.0	(4G10)	17.6
198217.1000	6FX8002-5CX28-1BA0*	10.0	(4G16)	21.2
<b>SINAMICS, speed-connect</b>				
198204.1000	6FX8002-5CN05-1BA0*		(4G1.5)	8.6

\* Siemens article designations are registered trademarks of Siemens AG, and are for reference purposes only

# Servo cable assemblies with brake cores for C-tracks

## Acc. to SIEMENS-6FX8002 standard Extension



### Application

- Extension, for Siemens servo drives
- Due to full PUR jacket and TPE conductor insulation optimally suited for c-tracks, extremely rough operating conditions, aggressive coolants and lubricants
- Especially for industrial environments, machines and plants

### Properties

- Silicone free
- RoHS-compliant
- The extension can also be used for **SPEED-CONNECT** plug connection, for this the O-ring must be removed on the outer thread. This does not affect the tightness of the plug connection.

### Technical data

UL approval	cURus
Nominal voltage	1000 V 80 °C
Voltage	
$U_0/U$	0.6/1 kV
Test voltage	4000 V
Insulation resistance	min. 500 MΩ × km
Temperature range	
moving	-25 °C to +80 °C
fixed	-40 °C to +80 °C
Minimum bending radius	
moving	D × 10
fixed	D × 6
Burning behavior	Flame-retardant according to VDE 0482 T 265-2, DIN EN 50265-2, IEC 60332-1, UL 1581 section 1080 VW-1, CSA FT 1
Halogen free	according to DIN EN 50267-2-1
Product photo	The product photos are not to scale and do not represent detailed images of the respective products.

### Construction

- Bare copper wire, finely stranded according to DIN VDE 0295 class 6, IEC 60228 class 6
- Special TPE/HGI conductor insulation, UL certified
- Conductor marking Power conductors black with numbered print U/L1/C/L+, V/L2, W/L3/D/L-
- Ground conductor green/yellow according to DIN EN 50334
- Control pair color-coded (bk, wh)
- Control pair with braided shield and foil tape
- Conductors cabled in layers
- without mechanical stress, optimised lay pitch
- Fleece wrap over cable core
- Braid from tinned copper wire, optical coverage ≥ 85 %
- Outer jacket Full polyurethane jacket, matte, adhesion-free surface
- Jacket color orange RAL 2003

Part-No.	SIEMENS designation	Length m	Number of conductors/cross-section	Outer Ø ca. mm
<b>SINAMICS/SIMODRIVE, full thread</b>				
198730.1000	6FX8002-5DA05-1BA0*	10.0	(4G1.5+(2×1.5))	11.4
198990.1000	6FX8002-5DA15-1BA0*	10.0	(4G2.5+(2×1.5))	12.9
198790.1000	6FX8002-5DA28-1BA0*	10.0	(4G1.5+(2×1.5))	11.4
198800.1000	6FX8002-5DA38-1BA0*	10.0	(4G2.5+(2×1.5))	12.9
198005.1000	6FX8002-5DA48-1BA0*	10.0	(4G4+(2×1.5))	14.5
198010.1000	6FX8002-5DA58-1BA0*	10.0	(4G6+(2×1.5))	16.1
198025.1000	6FX8002-5DA68-1BA0*	10.0	(4G10+(2×1.5))	19.5
198248.1000	6FX8002-5DX18-1BA0*	10.0	(4G10+(2×1.5))	19.5
198249.1000	6FX8002-5DX28-1BA0*	10.0	(4G16+(2×1.5))	23.6
198252.1000	6FX8002-5DX38-1BA0*	10.0	(4G25+(2×1.5))	28.5
198187.1000	6FX8002-5DX48-1BA0*	10.0	(4G35+(2×1.5))	32.0
198254.1000	6FX8002-5DX58-1BA0*	10.0	(4G50+(2×1.5))	37.3
<b>SINAMICS, speed-connect</b>				
198735.1000	6FX8002-5DN05-1BA0*		(4G1.5+(2×1.5))	11.4

\* Siemens article designations are registered trademarks of Siemens AG, and are for reference purposes only

# Signal cables for C-tracks

## Acc. to SIEMENS-6FX8002 standard Base cable DRIVE-CLIQ®



### Application

- Resolver cable
- Due to full PUR jacket and TPE conductor insulation optimally suited for c-tracks, extremely rough operating conditions, aggressive coolants and lubricants

### Properties

- Silicone free
- RoHS-compliant

### Technical data

UL approval	cURus
Nominal voltage	30 V 80 °C
Test voltage	500 V
Insulation resistance	min. 2000 MΩ × km
Temperature range	
moving	-25 °C to +80 °C
fixed	-40 °C to +80 °C
Minimum bending radius	
moving	D × 12
fixed	D × 6
Burning behavior	Flame-retardant according to VDE 0482 T 265-2, DIN EN 50265/2, IEC 60332-1, UL 1581 section 1080 VW-1 CSA FT 1
Halogen free	according to DIN EN 50267-2-1
Product photo	The product photos are not to scale and do not represent detailed images of the respective products.

Part-No.	SIEMENS designation	Length m	Outer Ø ca. mm
<b>SINAMICS</b>			
198890.1000	6FX8002-2DC00-1BA0*	10.0	6.8
198900.1000	6FX8002-2DC10-1BA0*	10.0	6.8
198910.1000	6FX8002-2DC20-1BA0*	10.0	6.8

### Construction

- Bare copper wire, finely stranded according to DIN VDE 0295 class 6, IEC 60228 class 6
- Special TPE conductor insulation, UL qualified
- Conductors color-coded for specific system
- Conductors cabled in layers without mechanical stress, layer pitch optimised
- Fleece wrap over cable core
- Braid from tinned copper wire, optical coverage ≥ 85 %
- Full polyurethane jacket, matte adhesion-free surface
- Jacket color green RAL 6018

\* Siemens article designations are registered trademarks of Siemens AG, and are for reference purposes only

# Signal cables for C-tracks

## Acc. to SIEMENS-6FX8002 standard base cable and extension



### Application

- Resolver cable
- Due to full PUR jacket and TPE conductor insulation optimally suited for c-tracks, extremely rough operating conditions, aggressive coolants and lubricants

### Properties

- Silicone free
- RoHS-compliant

### Technical data

UL approval	cURus
Nominal voltage	30 V 80 °C
Test voltage	500 V
Insulation resistance	min. 2000 MΩ × km
Temperature range	
moving	-25 °C to +80 °C
fixed	-40 °C to +80 °C
Minimum bending radius	
moving	D × 12
fixed	D × 6
Burning behavior	Flame-retardant according to VDE 0482 T 265-2, DIN EN 50265/2, IEC 60332-1, UL 1581 section 1080 VW-1 CSA FT 1
Halogen free	according to DIN EN 50267-2-1
Product photo	The product photos are not to scale and do not represent detailed images of the respective products.

### Construction

- Bare copper wire, finely stranded according to DIN VDE 0295 class 6, IEC 60228 class 6
- Special TPE conductor insulation, UL qualified
- Conductors color-coded for specific system
- Conductors cabled in layers without mechanical stress, layer pitch optimised
- Fleece wrap over cable core
- Braid from tinned copper wire, optical coverage ≥ 85 %
- Full polyurethane jacket, matte adhesion-free surface
- Jacket color green RAL 6018



Part-No.	SIEMENS designation	Length m	Outer Ø ca. mm
<b>SIMODRIVE base cable</b>			
198110.1000	6FX8002-2AD00-1BA0*	10.0	8.6
198830.1000	6FX8002-2AH00-1BA0*	10.0	9.0
198120.1000	6FX8002-2CA11-1BA0*	10.0	9.0
198130.1000	6FX8002-2CA15-1BA0*	10.0	8.6
198628.1000	6FX8002-2CA31-1BA0*	10.0	9.5
198850.1000	6FX8002-2CA51-1BA0*	10.0	8.6
198150.1000	6FX8002-2CA61-1BA0*	10.0	8.6
198200.1000	6FX8002-2CB51-1BA0*	10.0	9.0
198210.1000	6FX8002-2CC11-1BA0*	10.0	9.0
198220.1000	6FX8002-2CD01-1BA0*	10.0	9.0
198240.1000	6FX8002-2CF02-1BA0*	10.0	8.6
198170.1000	6FX8002-2CG00-1BA0*	10.0	9.0
198250.1000	6FX8002-2CH00-1BA0*	10.0	8.6
198280.1000	6FX8002-2EQ10-1BA0*	10.0	9.5
198140.1000	6FX8002-2CA21-1BA0*	10.0	8.6
198260.1000	6FX8002-2CE07-1BA0*	10.0	9.0
<b>SIMODRIVE extension</b>			
198160.1000	6FX8002-2CA34-1BA0*	10.0	9.5
198740.1000	6FX8002-2CF04-1BA0*	10.0	8.6
198700.1000	6FX8002-2EQ14-1BA0*	10.0	9.5
198105.1000	6FX8002-2AD04-1BA0*	10.0	8.6
198295.1000	6FX8002-2CB54-1BA0*	10.0	9.0

\* Siemens article designations are registered trademarks of Siemens AG, and are for reference purposes only

# Pre-fabricated front-end plug S7

## S7 Plug For Siemens Simatic PLC/S7



### Application

- Wiring from Siemens Simatic PLC/S7

### Properties

- Cable core with S7 connector
- Completely wired, 2. cables run at 90° to connector

### Technical data

Conductor marking	white number imprint, corresponding to the terminal location on the plug
Packaging	3 m or 5 m Other lengths are available upon request

### Construction

- Fully compatible to Siemens
- Color of conductor dark blue RAL5010

Part-No.	Type	Cable core	Cable construction	Length m
<b>S7 Plug with screw termination</b>				
197455	392 1AJ	20-pole	20×0.5	3.0
197456	392 1AJ	20-pole	20×0.5	5.0
197457	392 1AJ	20-pole	20×0.75	3.0
197458	392 1AJ	20-pole	20×0.75	5.0
197459	392 1AJ	20-pole	20×1.0	3.0
197460	392 1AJ	20-pole	20×1.0	5.0
197473	492 1AL	48-pole	48×0.5	3.0
197474	492 1AL	48-pole	48×0.5	5.0
197475	492 1AL	48-pole	48×0.75	3.0
197476	492 1AL	48-pole	48×0.75	5.0
197477	492 1AL	48-pole	48×1.0	3.0
197478	492 1AL	48-pole	48×1.0	5.0
<b>S7 Plug with Easy-Connect</b>				
197500	Compatible to 392 1AM	40-pole	40×0.5	3.0
197501	Compatible to 392 1AM	40-pole	40×0.5	5.0
197502	Compatible to 392 1AM	40-pole	40×0.75	3.0
197503	Compatible to 392 1AM	40-pole	40×0.75	5.0
197504	Compatible to 392 1AM	40-pole	40×1.0	3.0
197505	Compatible to 392 1AM	40-pole	40×1.0	5.0



# Patch cable, shielded

## Patch cable Cat 5E / Cat 6



### Application

- Ethernet network wiring

### Properties

- Straight connector
- Assignment according to EIA/TIA 568B
- Moulded sleeve with length imprint (not for c-tracks suitable and industrial construction)
- Various colors available (not for c-tracks suitable and industrial construction)

### Technical data

Connector	Shielded RJ45, 3μ–50μ AU
Wiring	according to EIA/TIA 568B 1:1 or crossover

### Construction

- Fully plug compatible to IEC 60603-7

#### • Cable

##### **Cat.5E:**

(4×2×AWG26) SFTP

##### **Cat.5E c-tracks suitable:**

PUR yellow (4×2×AWG26/19) SUTP

Oil-resistant according to EN60811-2-1

Alternating bending test (with load) according to VDE0472 T603

##### **Cat.6:**

(4×2×AWG27) SSTP

##### **Cat.6 industrial version:**

PUR red (4×2×AWG27/7) SSTP

Resistant to mineral oil, ASTM oil and UV radiation, highly abrasion-resistant

Suitable for outdoor areas, but not for laying directly in earth

Halogen free

#### • 1:1 wiring:

cables and protective sleeves in same color

The following colors can be supplied: grey, green, blue, yellow, red, black

#### **Crossover wiring:**

Cable in grey, protective sleeves in red

#### **C-track compatible PUR:**

Cable and protective sleeves yellow

Part-No.	Color	Wiring	Length m
<b>Cat.5E</b>			
192000.0100	grey	1:1	1.0
192022.0100	blue	1:1	1.0
192030.0100	green	1:1	1.0
192010.0100	grey/UL	1:1	1.0
<b>Cat.5E</b>			
192050.0100	grey	Crossover	1.0
<b>Cat.5E C-track compatible PUR</b>			
192300.0100	yellow	1:1	1.0
<b>Cat.6</b>			
192100.0100	grey	1:1	1.0
192112.0100	yellow	1:1	1.0
192130.0100	green	1:1	1.0
<b>Cat.6 industrial version PUR</b>			
192201.0100	red	1:1	1.0

# USB 3.0 (Super-Speed USB)

## USB 3.0 connection cables



### Application

- Connection technology for serial bus system

### Properties

- With the new standard USB 3.0, also called Super-Speed USB, transmission rates of up to 5Gbit/s are possible. This is equivalent to ten times the USB 2.0 standard.
- USB 3.0 remains downward compatible with the existing USB 2.0 devices.

### Technical data

Operating voltage	30 V
Temperature range	to + 80 °C
Outer Ø	5,5 ± 0,2 mm

### Construction

- Jacket color black, blue  
cables and sleeves in the same color  
RoHS compliant

Part-No.	Description	Length m	Color
192700.0100	USB 3.0 cable A/A	1.0	blue
192750.0100	USB 3.0 cable A/A 1:1	1.0	blue
192710.0100	USB 3.0 cable A/B	1.0	blue
192720.0100	USB 3.0 cable B/B	1.0	blue
192730.0100	USB 3.0 Micro B/A male	1.0	black
192740.0100	USB 3.0 cable A/A female	1.0	blue

# PUR Coil cables unshielded

## LÜTZE PURFLEX



### Application

- Machine and device construction, transport and conveyor technology
- Especially for industrial environments, machines and plants
- Lifting platforms, test benches and measuring systems as well as door drives

### Properties

- Very good restoring force
- Low adhesion, abrasion-proof, nick-resistant, tear-propagation-resistant
- Hydrolysis-resistant, microbe-resistant, and rot-resistant
- Weatherproof, ozone and UV resistant (normal lighting conditions)
- Good industrial- and salt water resistance
- Resistant to most oils, greases, alcohol-free benzines and kerosene
- Free from paint wetting disruptive substances (LABS-free), RoHS-compliant

### Technical data

Voltage	
$U_0/U$	300/500 V
Test voltage	3000 V
Insulation resistance	min. 20 M $\Omega$ × km
Temperature range	
moving	-20 °C to +80 °C
unmoving	-40 °C to +80 °C

### Construction

- Bare copper wire, multi-strand according to DIN VDE 0295 class 5, IEC 60228 class 5
- Special PVC conductor insulation
- Conductors colored according to DIN VDE 0293-308 (new)
- 2-wire: brown, blue
- 3-wire: greenyellow, brown, blue
- 4-wire: greenyellow, brown, black, grey
- 5-wire: greenyellow, blue, brown, black, grey
- starting with 6 conductors black with white number print according to DIN EN 50334
- Ground conductor green/yellow according to DIN EN 50334 in the top layer
- Polyurethane jacket, matte, adhesion-free surface
- Jacket color
- up to 7-wires orange RAL 2003
- starting with 12-wires black RAL 9005
- Cable outlet radial

Part-No.	Number of conductors/cross-section	Coil- $\emptyset$ mm	Spiral length L <sub>0</sub> mm	Max. extension length L mm	Connection end L1/L2 mm
<b>PURFLEX</b>					
190003	3G1.5	30	500	2250	250
190007	3G1.5	30	1000	4000	250
190012	3G1.5	30	1500	5750	250
190016	3G1.5	30	2000	7500	250
190004	4G1.5	33	500	2250	250
190008	4G1.5	33	1000	4000	250
190013	4G1.5	33	1500	5750	250
190017	4G1.5	33	2000	7500	250
190005	5G1.5	40	500	2250	250
190009	5G1.5	40	1000	4000	250
190014	5G1.5	40	1500	5750	250
190018	5G1.5	40	2000	7500	250
190559	5G1.5	40	2000	7000	600
190570	7G1.5	46	1000	4000	600
190560	7G1.5	46	2000	7000	600
190006	12G1.5	70	500	2250	250
190010	12G1.5	70	1000	4000	250
190015	12G1.5	70	1500	5750	250
190019	12G1.5	70	2000	7500	250

CE These products are in conformity with the EU Low Voltage Directive 2006/95/EC

# Design questionnaire for Coil cables

Company: \_\_\_\_\_

Contact person: \_\_\_\_\_

Department: \_\_\_\_\_

Street address: \_\_\_\_\_

Postal code, city/town: \_\_\_\_\_

Telephone: \_\_\_\_\_

Fax: \_\_\_\_\_



**Germany**  
 Friedrich Lütze GmbH  
 Tel.: +49 7151 6053-0  
 Fax: +49 7151 6053-277(-288)  
 info@luetze.de

**USA**  
 LUTZE INC.  
 Tel.: +1 704 504-0222  
 Fax: +1 704 504-0223  
 info@lutze.com

**Great Britain**  
 LUTZE Ltd.  
 Tel.: +44 1827 31333-0  
 Fax: +44 1827 31333-2  
 sales.gb@lutze.co.uk

**Please let us know your requirements using this design questionnaire for coil cables:**

L: \_\_\_\_\_ mm      L0: \_\_\_\_\_ mm

Ø AD: \_\_\_\_\_ mm      Ø WD: \_\_\_\_\_ mm

L1: \_\_\_\_\_ mm      L2: \_\_\_\_\_ mm

L3: \_\_\_\_\_ mm      L4: \_\_\_\_\_ mm

L5: \_\_\_\_\_ mm      L6: \_\_\_\_\_ mm

Quantity: \_\_\_\_\_ pcs.

**Purpose**

Installation situation: \_\_\_\_\_

\_\_\_\_\_

\_\_\_\_\_

Winding direction: \_\_\_\_\_

Standard cable art. no.: \_\_\_\_\_

Jacket insulation material: \_\_\_\_\_

Number of strands: \_\_\_\_\_

Strand cross-section: \_\_\_\_\_ mm<sup>2</sup>

Shielding:     yes       no

**Please fill out this questionnaire and fax it back to us. We will be happy to give you a quotation.**

**Thank you!**

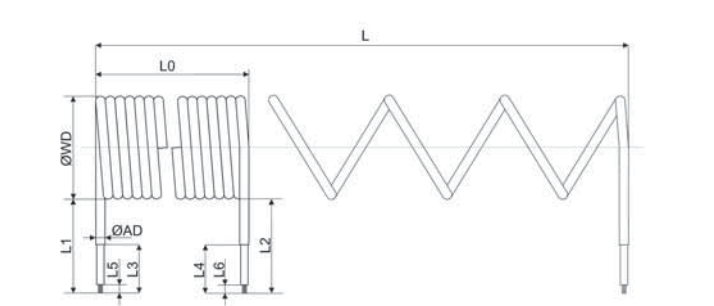

Cable outlets, radial

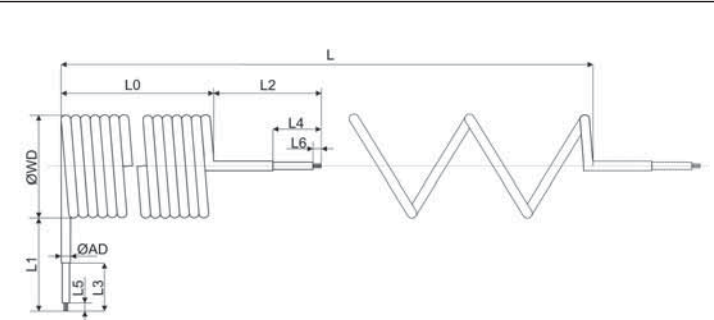

Cable outlets, radial and axial

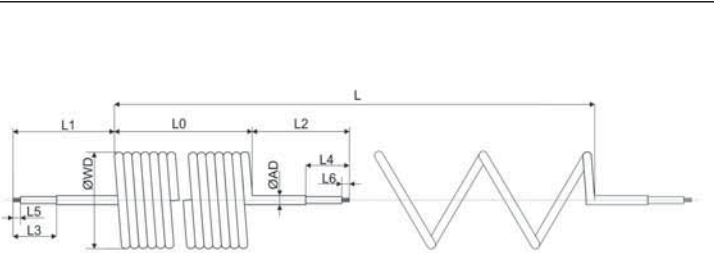

Cable outlets, axial

**Comments**

\_\_\_\_\_

\_\_\_\_\_

\_\_\_\_\_

# Construction questionnaire for LÜTZE Tamper-proof connector

Company: \_\_\_\_\_

Contact person: \_\_\_\_\_

Department: \_\_\_\_\_

Street address: \_\_\_\_\_

Postal code, city/town: \_\_\_\_\_

Telephone: \_\_\_\_\_

Fax: \_\_\_\_\_



**Germany**  
 Friedrich Lütze GmbH  
 Tel.: +49 7151 6053-0  
 Fax: +49 7151 6053-277(-288)  
 info@luetze.de

**USA**  
 LUTZE INC.  
 Tel.: +1 704 504-0222  
 Fax: +1 704 504 -0223  
 info@lutze.com

**Great Britain**  
 LUTZE Ltd.  
 Tel.: +44 1827 31333-0  
 Fax: +44 1827 31333-2  
 sales.gb@lutze.co.uk

**Please tell us your requirements by filling in this construction questionnaire:**

**Batch size:** \_\_\_\_\_ pieces

**Page 1**

**Page 2**

**Page 1 / View X**

clockwise  
 counterclockwise

**Signal**

**Pin layouts (more on request)**

**Power**

**Options**

Connector – inner thread M23 x 1  
 Connector – speedtec quick release fastener  
 Coupling – outer thread M23 x 1  
 Coupling – speedtec quick release fastener  
 Socket contacts     pin contacts  
 Signal coding:  0°    80°    120°    20°

**Cable**

Assembly length L: \_\_\_\_\_ mm

LÜTZE cable part number: \_\_\_\_\_

Description / Requirement / Purpose / Specification:  
 \_\_\_\_\_  
 \_\_\_\_\_

**Page 2 / View Y**

clockwise  
 counterclockwise

**Signal**

**Pin layouts (more on request)**

**Power**

**Options**

Connector – inner thread M23 x 1  
 Connector – speedtec quick release fastener  
 Coupling – outer thread M23 x 1  
 Coupling – speedtec quick release fastener  
 Socket contacts     pin contacts  
 Signal coding:  0°    80°    120°    20°  
 Other connectors Type/Version: \_\_\_\_\_  
 Manufacturer: \_\_\_\_\_  
 Manufacturer part number: \_\_\_\_\_

Manipulation cable end (strip, remove insulation, change screen, shrink tubing, copper tape etc.) –  
 Description: \_\_\_\_\_  
 \_\_\_\_\_  
 \_\_\_\_\_

Cable end cut smoothly

**Labelling**

Wrap-round label printing text distance to connector: \_\_\_\_\_

Cable printing text distance to connector: \_\_\_\_\_

Other labelling – Description: \_\_\_\_\_

No labelling

**Note: Please indicate pin assignment!**



## 7. Actuator sensor interface

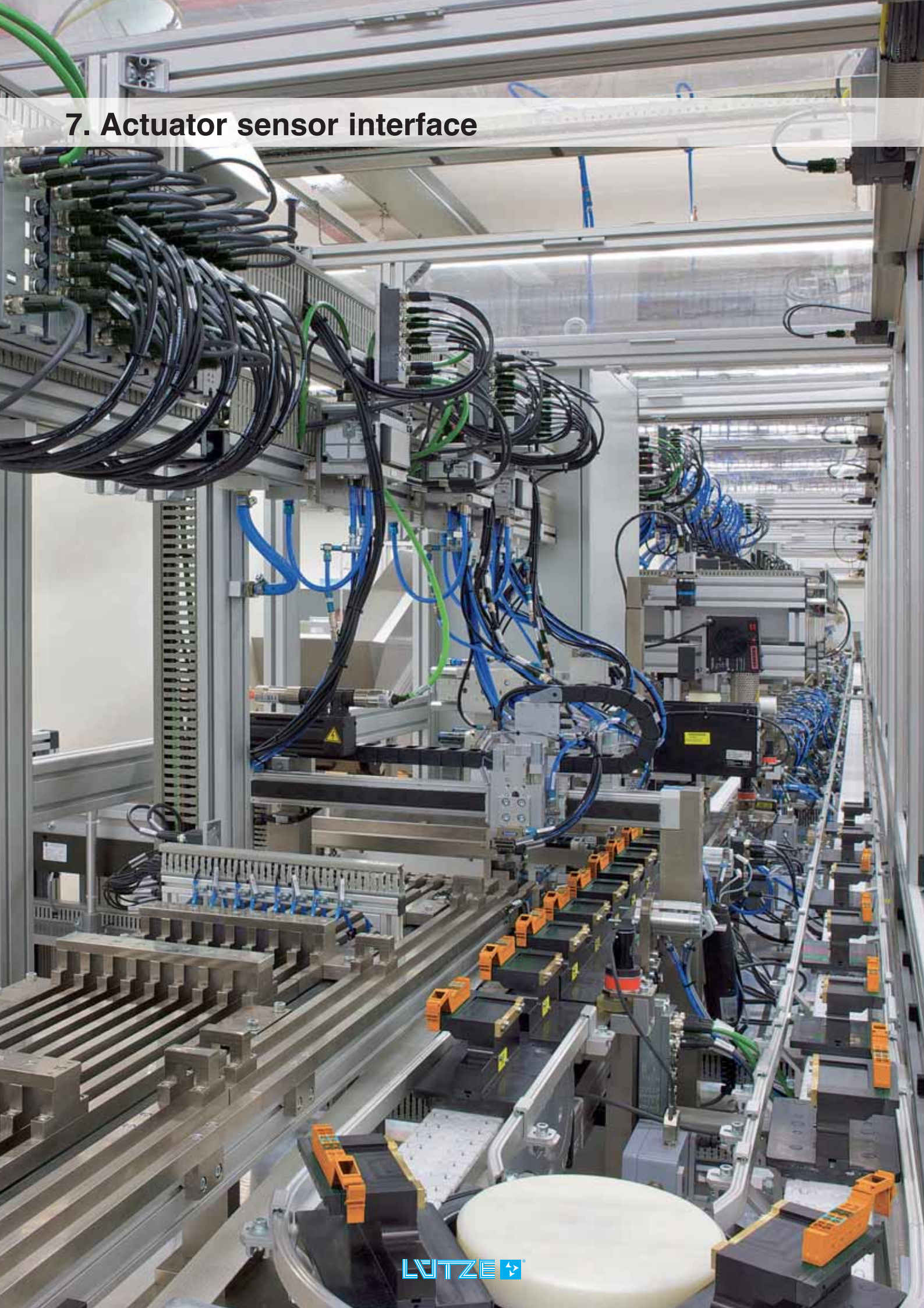

## 7. Actuator sensor interface



### Actuator sensor cables

M12 - Fieldbus cables (CANopen, DeviceNet and PROFIBUS)	7.4 - 7.12
M12 - Network cables (PROFINET)	7.13 - 7.14
M8 / open End - Cables	7.15 - 7.21
M8 / M8 - Cables	7.22 - 7.23
M12 / open End - Cables	7.24 - 7.36
M12 / M8 - Cables	7.37
M12 / M12 - Cables	7.38 - 7.43
M12 - Valve connector	7.44 - 7.47



### Connector, assembled freely

M8 - Connector	7.48 - 7.49
M12 - Connector	7.50 - 7.54
M12, M12 / M8 - Connector T piece	7.55
M12 - Connector for Field and netsystems	7.56 - 7.61
RJ45 Connector	7.62 - 7.63
RJ45 Module holder	7.64



### Panel connectors

M8 and M12 Panel connectors	7.65 - 7.66
USB - Panel connectors	7.67 - 7.68
RJ45 - Panel connectors	7.69
M12 - RJ45 Control cabinet bushing	7.70

### Accessories

M8, M12 Protective cover	7.71
M8, M12 Designation plate, designation sleeve	7.72
Classification Ethernet Cable and -connector	7.73



# LÜTZE SUPERFLEX® and LÜTZE SUPERFLEX® PLUS



## LÜTZE SUPERFLEX®

← *connected*

**LÜTZE SUPERFLEX® sets Industry Standards:  
longevity, reliability, flexibility**

LÜTZE SUPERFLEX® flexing cables are specifically designed for use in continuous motion applications such as drag chains.

Find here more informations  
about LÜTZE SUPERFLEX®  
<http://bit.ly/ZUdgUK>



# Actuator sensor interface - CANopen field bus cables

Male M12 straight with PUR cable, shielded 360°, open end self-locking screwed connection  
c-track compatible, halogen free



### Dimensions



### PIN assignment



### Circuit diagram

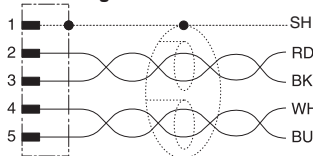

Description	Part-No.	Type	PU	
Cable length (m)	2.0	475702	STG5-M12/CAN 2M-PUR	1
	5.0	475705	STG5-M12/CAN 5M-PUR	1
	10.0	475710	STG5-M12/CAN 10M-PUR	1

### Technical data

Nominal voltage	AC/DC 24 V		
Nominal voltage range	max. 30 V		
Rated current	4 A		
Pol number	5		
Cable length (m)	2.0	5.0	10.0
Status Indication	-		
Current Consumption per LED	-		
Coding	A		
Shielding	360°		

### General

Form	M12 × 1, male straight		
Rated insulation voltage (EN 50178)	60 V		
Test voltage	1.5 kV		
Pollution degree	3		
Insulation resistance	>10 <sup>9</sup> Ω		
Contact resistance	< 5 mΩ		
Class of flammability according to UL 94	V0		
Protection class	IP65/IP67		
Housing material	TPU black		
Contact material	CuSn, gold plated nickel		
Thread material	Zinc die-casting, nickel-plated		
Gasket	-		
Cable construction	2 × AWG 22/19 + 2 × AWG 24/19 + Drainwire AWG 22/19		
Cable jacket	PUR, RAL 4001 violet		
Conductor insulation	PE		
Cable diameter	6.7 mm		
Bending radius	15 x cable diameter		
Storage temperature range	-40 °C – 90 °C		
Temperature range connector	-25 °C – 90 °C		
Temperature range cable fixed	-40 °C – 80 °C		
Temperature range cable moving	-20 °C – 75 °C		
Mechanical service life	-		
Weight (kg/piece)	0.135	0.305	0.605

Approvals the cable is UL, CSA certified 80° 300V

Accessories	Article number	Type	PU
Cable markers 4×23mm	499988	LB M8/M12	5
Torque setting tool M12	490091	DM-SET M12	1

### Comments

Angled onstruction item no. 498030.xxxx

# Actuator sensor interface - CANopen field bus cables

Female M12 straight with PUR cable, shielded 360°, open end self-locking screwed connection  
c-track compatible, halogen free



## Dimensions

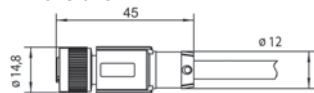

## PIN assignment



## Circuit diagram

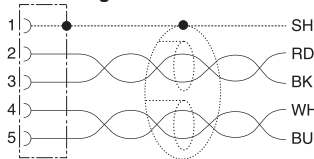

Description	Part-No.	Type	PU	
Cable length (m)	2.0	475802	KUG5-M12/CAN 2M-PUR	1
	5.0	475805	KUG5-M12/CAN 5M-PUR	1
	10.0	475810	KUG5-M12/CAN 10M-PUR	1

## Technical data

Nominal voltage	AC/DC 24 V		
Nominal voltage range	max. 30 V		
Rated current	4 A		
Pol number	5		
Cable length (m)	2.0	5.0	10.0
Status Indication	-		
Current Consumption per LED	-		
Coding	A		
Shielding	360°		

## General

Form	M12 × 1, female straight		
Rated insulation voltage (EN 50178)	60 V		
Test voltage	1.5 kV		
Pollution degree	3		
Insulation resistance	>10 <sup>9</sup> Ω		
Contact resistance	< 5 mΩ		
Class of flammability according to UL 94	V0		
Protection class	IP65/IP67		
Housing material	TPU black		
Contact material	CuSn, gold plated nickel		
Thread material	Zinc die-casting, nickel-plated		
Gasket	NBR		
Cable construction	2 × AWG 22/19 + 2 × AWG 24/19 + Drainwire AWG 22/19		
Cable jacket	PUR, RAL 4001 violet		
Conductor insulation	PE		
Cable diameter	6.7 mm		
Bending radius	15 x cable diameter		
Storage temperature range	-40 °C – 90 °C		
Temperature range connector	-25 °C – 90 °C		
Temperature range cable fixed	-40 °C – 80 °C		
Temperature range cable moving	-20 °C – 75 °C		
Mechanical service life	-		
Weight (kg/piece)	0.135	0.305	0.605
Approvals	the cable is UL, CSA certified 80° 300V		

Accessories	Article number	Type	PU
Cable markers 4×23mm	499988	LB M8/M12	5
Torque setting tool M12	490091	DM-SET M12	1

## Comments

Angled construction item no. 498031.xxxx

# Actuator sensor interface - CANopen field bus cables

Male-female M12 straight with PUR cable, shielded 360°  
self-locking screwed connection  
c-track compatible, halogen free



## Dimensions

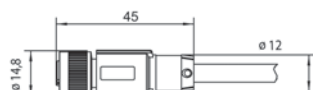
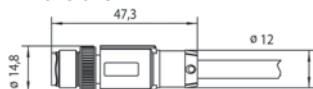

## PIN assignment

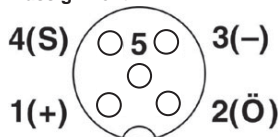

## Circuit diagram

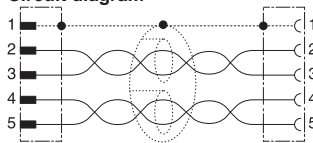

Description	Part-No.	Type	PU
Cable length (m)	0.3	475903	STG5-M12/KUG5-M12/CAN 0,3M-PUR 1
	0.5	475905	STG5-M12/KUG5-M12/CAN 0,5M-PUR 1
	1.0	475910	STG5-M12/KUG5-M12/CAN 1,0M-PUR 1
	1.5	475915	STG5-M12/KUG5-M12/CAN 1,5M-PUR 1
	2.0	475920	STG5-M12/KUG5-M12/CAN 2,0M-PUR 1
	3.0	475930	STG5-M12/KUG5-M12/CAN 3,5M-PUR 1
	5.0	475950	STG5-M12/KUG5-M12/CAN 5,0M-PUR 1

## Technical data

Nominal voltage	AC/DC 24 V						
Nominal voltage range	max. 30 V						
Rated current	4 A						
Pol number	5						
Cable length (m)	0.3	0.5	1.0	1.5	2.0	3.0	5.0
Status Indication	-						
Current Consumption per LED	-						
Coding	A						
Shielding	360°						

## General

Form	M12 × 1, male - female straight						
Rated insulation voltage (EN 50178)	60 V						
Test voltage	1.5 kV						
Pollution degree	3						
Insulation resistance	>10 <sup>9</sup> Ω						
Contact resistance	< 5 mΩ						
Class of flammability according to UL 94	V0						
Protection class	IP65/IP67						
Housing material	TPU black						
Contact material	CuSn, gold plated nickel						
Thread material	Zinc die-casting, nickel-plated						
Gasket	NBR (female)						
Cable construction	2 × AWG 22/19 + 2 × AWG 24/19 + Drainwire AWG 22/19						
Cable jacket	PUR, RAL 4001 violet						
Conductor insulation	PE						
Cable diameter	6.7 mm						
Bending radius	15 x cable diameter						
Storage temperature range	-40 °C – 90 °C						
Temperature range connector	-25 °C – 90 °C						
Temperature range cable fixed	-40 °C – 80 °C						
Temperature range cable moving	-20 °C – 75 °C						
Mechanical service life	-						
Weight (kg/piece)	0.055	0.070	0.100	0.125	0.150	0.230	0.315
Approvals	the cable is UL, CSA certified 80° 300V						

Accessories	Article number	Type	PU
Cable markers 4×23mm	499988	LB M8/M12	5
Torque setting tool M12	490091	DM-SET M12	1

# Actuator sensor interface - DeviceNet field bus cables

Male M12 straight with PUR cable, shielded 360°, open end self-locking screwed connection  
c-track compatible, halogen free



### Dimensions

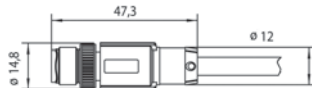

### PIN assignment

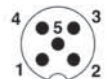

### Circuit diagram

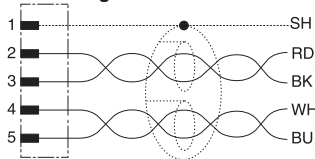

Description	Part-No.	Type	PU	
Cable length (m)	2.0	496702	STG5-M12/DN 2M-PUR	1
	5.0	496705	STG5-M12/DN 5M-PUR	1
	10.0	496710	STG5-M12/DN 10M-PUR	1
<b>Technical data</b>				
Nominal voltage	AC/DC 24 V			
Nominal voltage range	max. 30 V			
Rated current	4 A			
Pol number	5			
Cable length (m)	2.0	5.0	10.0	
Status Indication	-			
Current Consumption per LED	-			
Coding	A			
Shielding	360°			
<b>General</b>				
Form	M12 × 1, male straight			
Rated insulation voltage (EN 50178)	60 V			
Test voltage	1.5 kV			
Pollution degree	3			
Insulation resistance	>10 <sup>9</sup> Ω			
Contact resistance	< 5 mΩ			
Class of flammability according to UL 94	V0			
Protection class	IP65/IP67			
Housing material	TPU black			
Contact material	CuSn, gold plated nickel			
Thread material	Zinc die-casting, nickel-plated			
Gasket	-			
Cable construction	2 × AWG 22/19 + 2 × AWG 24/19 + Drainwire AWG 22/19			
Cable jacket	PUR, RAL 4001 violet			
Conductor insulation	PE			
Cable diameter	6.7 mm			
Bending radius	15 x cable diameter			
Storage temperature range	-40 °C – 90 °C			
Temperature range connector	-25 °C – 90 °C			
Temperature range cable fixed	-40 °C – 80 °C			
Temperature range cable moving	-20 °C – 75 °C			
Mechanical service life	-			
Weight (kg/piece)	0.135	0.305	0.605	
Approvals	the cable is UL, CSA certified 80° 300V			
<b>Accessories</b>				
	<b>Article number</b>	<b>Type</b>	<b>PU</b>	
Cable markers 4×23mm	499988	LB M8/M12	5	
Torque setting tool M12	490091	DM-SET M12	1	

# Actuator sensor interface - DeviceNet field bus cables

Female M12 straight with PUR cable, shielded 360°, open end  
self-locking screwed connection  
c-track compatible, halogen free



## Dimensions

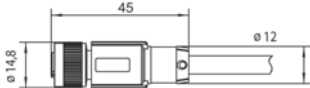

## PIN assignment



## Circuit diagram

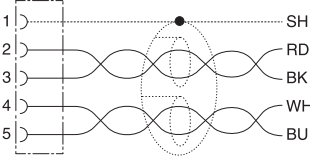

Description	Part-No.	Type	PU	
Cable length (m)	2.0	496802	KUG5-M12/DN 2M-PUR	1
	5.0	496805	KUG5-M12/DN 5M-PUR	1
	10.0	496810	KUG5-M12/DN 10M-PUR	1

## Technical data

Nominal voltage	AC/DC 24 V		
Nominal voltage range	max. 30 V		
Rated current	4 A		
Pol number	5		
Cable length (m)	2.0	5.0	10.0
Status Indication	-		
Current Consumption per LED	-		
Coding	A		
Shielding	360°		

## General

Form	M12 × 1, female straight		
Rated insulation voltage (EN 50178)	60 V		
Test voltage	1.5 kV		
Pollution degree	3		
Insulation resistance	>10 <sup>9</sup> Ω		
Contact resistance	< 5 mΩ		
Class of flammability according to UL 94	V0		
Protection class	IP65/IP67		
Housing material	TPU black		
Contact material	CuSn, gold plated nickel		
Thread material	Zinc die-casting, nickel-plated		
Gasket	NBR		
Cable construction	2 × AWG 22/19 + 2 × AWG 24/19 + Drainwire AWG 22/19		
Cable jacket	PUR, RAL 4001 violet		
Conductor insulation	PE		
Cable diameter	6.7 mm		
Bending radius	15 x cable diameter		
Storage temperature range	-40 °C – 90 °C		
Temperature range connector	-25 °C – 90 °C		
Temperature range cable fixed	-40 °C – 80 °C		
Temperature range cable moving	-20 °C – 75 °C		
Mechanical service life	-		
Weight (kg/piece)	0.135	0.305	0.605
Approvals	the cable is UL, CSA certified 80° 300V		
<b>Accessories</b>	<b>Article number</b>	<b>Type</b>	<b>PU</b>
Cable markers 4×23mm	499988	LB M8/M12	5
Torque setting tool M12	490091	DM-SET M12	1

# Actuator sensor interface - DeviceNet field bus cables

Male-female M12 straight with PUR cable, shielded 360°  
self-locking screwed connection  
c-track compatible, halogen free



## Dimensions

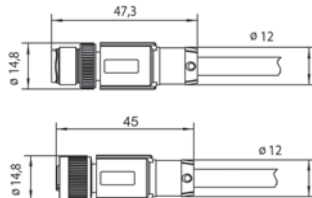

## PIN assignment

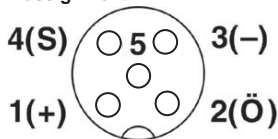

## Circuit diagram

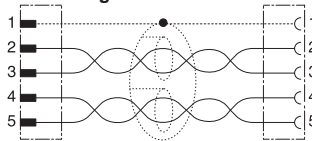

Description	Part-No.	Type	PU	
Cable length (m)	0.3	496903	STG5-M12/KUG5-M12/DN 0,3M-PUR	1
	0.5	496905	STG5-M12/KUG5-M12/DN 0,5M-PUR	1
	0.6	496906	STG5-M12/KUG5-M12/DN 0,6M-PUR	1
	0.7	496907	STG5-M12/KUG5-M12/DN 0,7M-PUR	1
	0.8	496908	STG5-M12/KUG5-M12/DN 0,8M-PUR	1
	1.0	496910	STG5-M12/KUG5-M12/DN 1,0M-PUR	1
	1.5	496915	STG5-M12/KUG5-M12/DN 1,5M-PUR	1
	2.0	496920	STG5-M12/KUG5-M12/DN 2,0M-PUR	1
	3.0	496930	STG5-M12/KUG5-M12/DN 3,5M-PUR	1
	5.0	496950	STG5-M12/KUG5-M12/DN 5,0M-PUR	1

## Technical data

Nominal voltage	AC/DC 24 V									
Nominal voltage range	max. 30 V									
Rated current	4 A									
Pol number	5									
Cable length (m)	0.3	0.5	0.6	0.7	0.8	1.0	1.5	2.0	3.0	5.0
Status Indication	-									
Current Consumption per LED	-									
Coding	A									
Shielding	360°									

## General

Form	M12 × 1, male - female straight									
Rated insulation voltage (EN 50178)	60 V									
Test voltage	1.5 kV									
Pollution degree	3									
Insulation resistance	>10 <sup>9</sup> Ω									
Contact resistance	< 5 mΩ									
Class of flammability according to UL 94	V0									
Protection class	IP65/IP67									
Housing material	TPU black									
Contact material	CuSn, gold plated nickel									
Thread material	Zinc die-casting, nickel-plated									
Gasket	NBR (female)									
Cable construction	2 × AWG 22/19 + 2 × AWG 24/19 + Drainwire AWG 22/19									
Cable jacket	PUR, RAL 4001 violet									
Conductor insulation	PE									
Cable diameter	6.7 mm									
Bending radius	15 x cable diameter									
Storage temperature range	-40 °C – 90 °C									
Temperature range connector	-25 °C – 90 °C									
Temperature range cable fixed	-40 °C – 80 °C									
Temperature range cable moving	-20 °C – 75 °C									
Mechanical service life	-									
Weight (kg/piece)	0.055	0.070	0.075	0.080	0.085	0.100	0.125	0.150	0.230	0.315
Approvals	the cable is UL, CSA certified 80° 300V									
<b>Accessories</b>	<b>Article number</b>	<b>Type</b>	<b>PU</b>							
Cable markers 4×23mm	499988	LB M8/M12	5							
Torque setting tool M12	490091	DM-SET M12	1							

# Actuator sensor interface - CORD SET PROFIBUS

Male M12 straight with PUR cable, shielded 360°, end open  
self-locking screwed connection  
c-track compatible, halogen free



## Dimensions



## PIN assignment

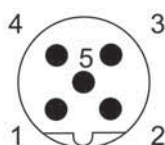

## Circuit diagram

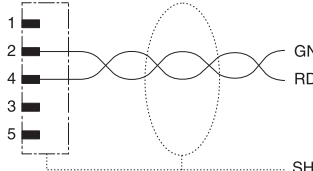

Description	Part-No.	Type	PU	
Cable length (m)	2.0	475302	STG2-M12/PB 2M-PUR	1
	5.0	475305	STG2-M12/PB 5M-PUR	1
	10.0	475310	STG2-M12/PB 10M-PUR	1

## Technical data

Nominal voltage	AC/DC 24 V		
Nominal voltage range	max. 30 V		
Rated current	4 A		
Pol number	2		
Cable length (m)	2.0	5.0	10.0
Status Indication	-		
Current Consumption per LED	-		
Coding	B - invers		
Shielding	360°		

## General

Form	M12 × 1, male straight		
Rated insulation voltage (EN 50178)	60 V		
Test voltage	1.5 kV		
Pollution degree	3		
Insulation resistance	>10 <sup>9</sup> Ω		
Contact resistance	< 5 mΩ		
Class of flammability according to UL 94	V0		
Protection class	IP65/IP67		
Housing material	TPU black		
Contact material	CuSn, gold plated nickel		
Thread material	Zinc die-casting, nickel-plated		
Gasket	-		
Cable construction	1 × 2 × 0.64 mm / AWG 24/19		
Cable jacket	PUR, RAL 4001 violet		
Conductor insulation	Shield, red, green		
Cable diameter	7.8 mm		
Bending radius	cable diameter		
Storage temperature range	-40 °C – 90 °C		
Temperature range connector	-25 °C – 90 °C		
Temperature range cable fixed	-40 °C – 80 °C		
Temperature range cable moving	-20 °C – 80 °C		
Mechanical service life	-		
Weight (kg/piece)	0.160	0.350	0.675
Approvals	the cable is UL, CSA certified 80° 300V		

Accessories	Article number	Type	PU
Cable markers 4×23mm	499988	LB M8/M12	5
Torque setting tool M12	490091	DM-SET M12	1



# Actuator sensor interface - CORD SET PROFIBUS

Female M12 straight with PUR cable, shielded 360°, end open  
self-locking screwed connection  
c-track compatible, halogen free



### Dimensions

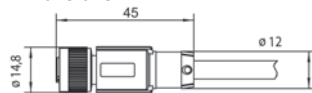

### PIN assignment

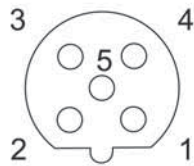

### Circuit diagram

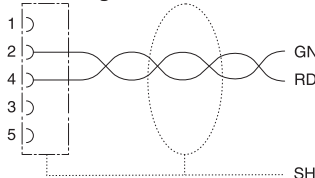

Description	Part-No.	Type	PU
Cable length (m)	2.0	KUG2-M12/PB 2M-PUR	1
	5.0	KUG2-M12/PB 5M-PUR	1
	10.0	KUG2-M12/PB 10M-PUR	1

### Technical data

Nominal voltage	AC/DC 24 V		
Nominal voltage range	max. 30 V		
Rated current	4 A		
Pol number	2		
Cable length (m)	2.0	5.0	10.0
Status Indication	-		
Current Consumption per LED	-		
Coding	B - invers		
Shielding	360°		

### General

Form	M12 × 1, female straight		
Rated insulation voltage (EN 50178)	60 V		
Test voltage	1.5 kV		
Pollution degree	3		
Insulation resistance	>10 <sup>9</sup> Ω		
Contact resistance	< 5 mΩ		
Class of flammability according to UL 94	V0		
Protection class	IP65/IP67		
Housing material	TPU black		
Contact material	CuSn, gold plated nickel		
Thread material	Zinc die-casting, nickel-plated		
Gasket	-		
Cable construction	1 × 2 × 0.64 mm / AWG 24/19		
Cable jacket	PUR, RAL 4001 violet		
Conductor insulation	Shield, red, green		
Cable diameter	7.8 mm		
Bending radius	10 x cable diameter		
Storage temperature range	-40 °C – 90 °C		
Temperature range connector	-25 °C – 90 °C		
Temperature range cable fixed	-40 °C – 80 °C		
Temperature range cable moving	-20 °C – 80 °C		
Mechanical service life	-		
Weight (kg/piece)	0.160	0.350	0.675
Approvals	the cable is UL, CSA certified 80° 300V		

Accessories	Article number	Type	PU
Cable markers 4×23mm	499988	LB M8/M12	5
Torque setting tool M12	490091	DM-SET M12	1

# Actuator sensor interface - CORD SET PROFIBUS

Male-female M12 straight with PUR cable, shielded 360°  
self-locking screwed connection  
c-track compatible, halogen free



## Dimensions

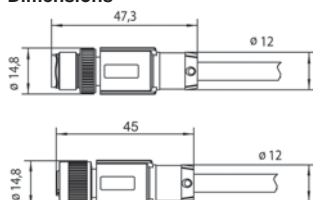

## PIN assignment

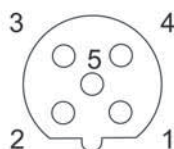
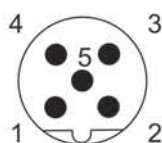

## Circuit diagram

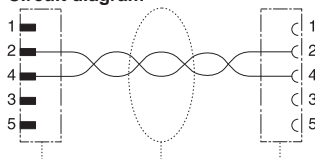

Description	Part-No.	Type	PU
Cable length (m)	0.3	475503	STG2-M12/KUG2-M12/PB 0,3M-PUR 1
	0.6	475506	STG2-M12/KUG2-M12/PB 0,6M-PUR 1
	1.0	475510	STG2-M12/KUG2-M12/PB 1,0M-PUR 1
	1.5	475515	STG2-M12/KUG2-M12/PB 1,5M-PUR 1
	2.0	475520	STG2-M12/KUG2-M12/PB 2,0M-PUR 1
	5.0	475550	STG2-M12/KUG2-M12/PB 5,0M-PUR 1

## Technical data

Nominal voltage	AC/DC 24 V					
Nominal voltage range	max. 30 V					
Rated current	4 A					
Pol number	2					
Cable length (m)	0.3	0.6	1.0	1.5	2.0	5.0
Status Indication	-					
Current Consumption per LED	-					
Coding	B - invers					
Shielding	360°					

## General

Form	M12 × 1, male - female straight					
Rated insulation voltage (EN 50178)	60 V					
Test voltage	1.5 kV					
Pollution degree	3					
Insulation resistance	>10 <sup>9</sup> Ω					
Contact resistance	< 5 mΩ					
Class of flammability according to UL 94	V0					
Protection class	IP65/IP67					
Housing material	TPU black					
Contact material	CuSn, gold plated nickel					
Thread material	Zinc die-casting, nickel-plated					
Gasket	NBR (female)					
Cable construction	1 × 2 × 0.64 mm / AWG 24/19					
Cable jacket	PUR, RAL 4001 violet					
Conductor insulation	Shield, red, green					
Cable diameter	7.8 mm					
Bending radius	10 x cable diameter					
Storage temperature range	-40 °C – 90 °C					
Temperature range connector	-25 °C – 90 °C					
Temperature range cable fixed	-40 °C – 80 °C					
Temperature range cable moving	-20 °C – 80 °C					
Mechanical service life	-					
Weight (kg/piece)	0.060	0.080	0.105	0.140	0.017	0.365

Approvals	the cable is UL, CSA certified 80° 300V		
<b>Accessories</b>	<b>Article number</b>	<b>Type</b>	<b>PU</b>
Cable markers 4×23mm	499988	LB M8/M12	5
Torque setting tool M12	490091	DM-SET M12	1

# Actuator sensor interface - Network cables PROFINET

Male M12 straight with PUR cable, shielded 360°, open end self-locking screwed connection  
c-track compatible, halogen free



### Dimensions

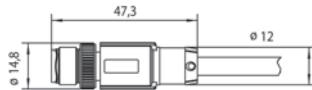

### PIN assignment

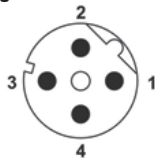

### Circuit diagram

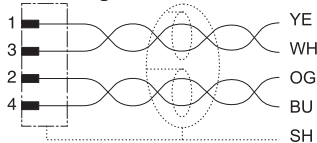

Description	Part-No.	Type	PU	
Cable length (m)	2.0	475300.0200	STG4-M12/PN 2M-PUR	1
	5.0	475300.0500	STG4-M12/PN 5M-PUR	1
	10.0	475300.1000	STG4-M12/PN 10M-PUR	1

### Technical data

Nominal voltage	AC/DC 24 V		
Nominal voltage range	max. 30 V		
Rated current	4 A		
Pol number	4		
Cable length (m)	2.0	5.0	10.0
Status Indication	-		
Current Consumption per LED	-		
Coding	D		
Shielding	360°		

### General

Form	M12 × 1, male straight		
Rated insulation voltage (EN 50178)	250 V		
Test voltage	1.5 kV		
Pollution degree	3		
Insulation resistance	>10 <sup>9</sup> Ω		
Contact resistance	< 5 mΩ		
Class of flammability according to UL 94	V0		
Protection class	IP65/IP67		
Housing material	TPU black		
Contact material	CuSn, gold plated nickel		
Thread material	Zinc die-casting, nickel-plated		
Gasket	-		
Cable construction	1 × 4 × AWG 22/7		
Cable jacket	PUR, RAL 6018 green		
Conductor insulation	white/yellow/blue/orange		
Cable diameter	6.5 mm		
Bending radius	10 x cable diameter		
Storage temperature range	-40 °C – 90 °C		
Temperature range connector	-25 °C – 90 °C		
Temperature range cable fixed	-40 °C – 70 °C		
Temperature range cable moving	-40 °C – 70 °C		
Mechanical service life	-		
Weight (kg/piece)	0.140	0.330	0.640

Approvals the cable is UL, CSA certified 80° 300V

Accessories	Article number	Type	PU
Cable markers 4×23mm	499988	LB M8/M12	5
Torque setting tool M12	490091	DM-SET M12	1

# Actuator sensor interface - Network cables PROFINET

Male M12 straight on male M12 straight with PUR cable, shielded 360°  
self-locking screwed connection  
c-track compatible, halogen free



## Dimensions



## PIN assignment

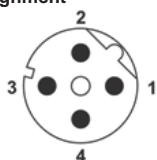

## Circuit diagram

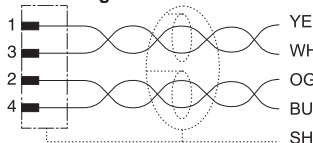

Description	Part-No.	Type	PU
Cable length (m)	0.3	475400.0030	STG4-M12/STG4-M12/PN 0,3M PUR 1
	0.6	475400.0060	STG4-M12/STG4-M12/PN 0,6M PUR 1
	1.0	475400.0100	STG4-M12/STG4-M12/PN 1,0M PUR 1
	1.5	475400.0150	STG4-M12/STG4-M12/PN 1,5M PUR 1
	2.0	475400.0200	STG4-M12/STG4-M12/PN 2,0M PUR 1
	5.0	475400.0500	STG4-M12/STG4-M12/PN 5,0M PUR 1

## Technical data

Nominal voltage	AC/DC 24 V					
Nominal voltage range	max. 30 V					
Rated current	4 A					
Pol number	4					
Cable length (m)	0.3	0.6	1.0	1.5	2.0	5.0
Status Indication	-					
Current Consumption per LED	-					
Coding	D					
Shielding	360°					

## General

Form	M12 × 1, male straight / M12 × 1, male straight					
Rated insulation voltage (EN 50178)	250 V					
Test voltage	1.5 kV					
Pollution degree	3					
Insulation resistance	>10 <sup>9</sup> Ω					
Contact resistance	< 5 mΩ					
Class of flammability according to UL 94	V0					
Protection class	IP65/IP67					
Housing material	TPU black					
Contact material	CuSn, gold plated nickel					
Thread material	Tin die casting, nickel-plated					
Gasket	-					
Cable construction	1 × 4 × AWG 22/7					
Cable jacket	PUR, RAL 6018 green					
Conductor insulation	white/yellow/blue/orange					
Cable diameter	6.5 mm					
Bending radius	10 x cable diameter					
Storage temperature range	-30 °C – 90 °C					
Temperature range connector	-25 °C – 90 °C					
Temperature range cable fixed	-40 °C – 70 °C					
Temperature range cable moving	-40 °C – 70 °C					
Mechanical service life	-					
Weight (kg/piece)	0.060	0.070	0.090	0.110	0.150	0.325

Approvals the cable is UL, CSA certified 80° 300V

Accessories	Article number	Type	PU
Cable markers 4×23mm	499988	LB M8/M12	5
Torque setting tool M12	490091	DM-SET M12	1

# Actuator sensor interface - M8 – cables

Male M8 straight with PUR cable, open end  
self-locking screwed connection  
c-track compatible, halogen free



## Dimensions

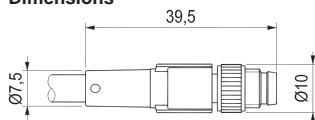

## PIN assignment

486020, 486050, 486100



447020, 447050, 447100



## Circuit diagram

486020, 486050, 486100

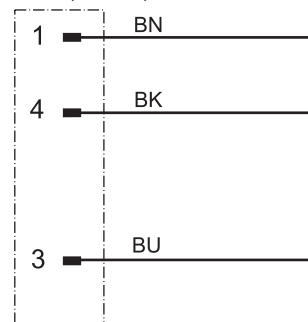

447020, 447050, 447100

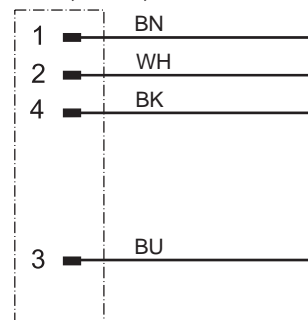

Description	Part-No.	Type	PU			
<b>3-pole</b>						
Cable length (m)	2.0	486020	STG3-M8 2M-PUR	1		
	5.0	486050	STG3-M8 5M-PUR	1		
	10.0	486100	STG3-M8 10M-PUR	1		
<b>4-pole</b>						
Cable length (m)	2.0	447020	STG4-M8 2M-PUR	1		
	5.0	447050	STG4-M8 5M-PUR	1		
	10.0	447100	STG4-M8 10M-PUR	1		
<b>Technical data</b>						
	<b>3-pole</b>		<b>4-pole</b>			
Nominal voltage	AC/DC 24 V					
Nominal voltage range	max. 30 V					
Rated current	4 A					
Pol number	3		4			
Cable length (m)	2.0	5.0	10.0	2.0	5.0	10.0
Status Indication	-					
Current Consumption per LED	-					
Coding	-					
Shielding	-					
<b>General</b>						
Form	M8 × 1, male straight					
Rated insulation voltage (EN 50178)	100 V					
Test voltage	1.5 kV					
Pollution degree	3					
Insulation resistance	>10 <sup>9</sup> Ω					
Contact resistance	< 5 mΩ					
Class of flammability according to UL 94	V0					
Protection class	IP65/IP67/IP68					
Housing material	TPU black					
Contact material	CuSn, gold plated nickel					
Thread material	Zinc die-casting, nickel-plated					
Gasket	-					
Cable construction	3 × 0.25mm <sup>2</sup> (32 × 0.1)			4 × 0.25mm <sup>2</sup> (32 × 0.1)		
Cable jacket	PUR black					
Conductor insulation	PP					
Cable diameter	4.4 mm					
Bending radius	10 x cable diameter					
Storage temperature range	-30 °C – 90 °C					
Temperature range connector	-25 °C – 90 °C					
Temperature range cable fixed	-40 °C – 80 °C					
Temperature range cable moving	-25 °C – 80 °C					
Mechanical service life	-					
Weight (kg/piece)	0.05	0.14	0.27	0.07	0.16	0.32
Approvals	cULus					
<b>Accessories</b>				<b>Article number</b>	<b>Type</b>	<b>PU</b>
Cable markers 4×23mm				499988	LB M8/M12	5
Torque setting tool M8				490090	DM-SET M8	1

# Actuator sensor interface - M8 – cables

Male M8 straight with PUR cable, shielded 360°, open end self-locking screwed connection  
c-track compatible, halogen free



### Dimensions

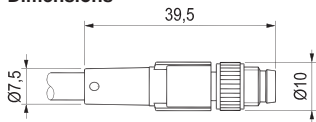

### PIN assignment



### Circuit diagram

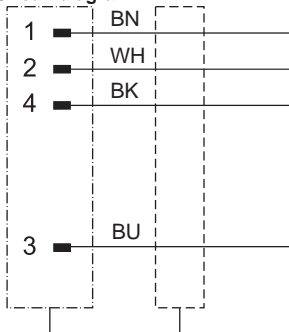

Description	Part-No.	Type	PU	
<b>4-pole</b>				
Cable length (m)	2.0	458202	STG4-M8 (C) 2M-PUR	1
	5.0	458205	STG4-M8 (C) 5M-PUR	1
	10.0	458210	STG4-M8 (C) 10M-PUR	1

Technical data		4-pole	
Nominal voltage		AC/DC 24 V	
Nominal voltage range		max. 30 V	
Rated current		4 A	
Pol number		4	
Cable length (m)	2.0	5.0	10.0
Status Indication		-	
Current Consumption per LED		-	
Coding		-	
Shielding		360°	

General	
Form	M8 × 1, male straight
Rated insulation voltage (EN 50178)	100 V
Test voltage	1.5 kV
Pollution degree	3
Insulation resistance	>10 <sup>9</sup> Ω
Contact resistance	< 5 mΩ
Class of flammability according to UL 94	V0
Protection class	IP65/IP67
Housing material	TPU black
Contact material	CuSn, gold plated nickel
Thread material	Zinc die-casting, nickel-plated
Gasket	-
Cable construction	4 × 0.25mm <sup>2</sup> (32 × 0.1)
Cable jacket	PUR black
Conductor insulation	PP
Cable diameter	5.0 mm
Bending radius	10 x cable diameter
Storage temperature range	-30 °C – 90 °C
Temperature range connector	-25 °C – 90 °C
Temperature range cable fixed	-40 °C – 80 °C
Temperature range cable moving	-25 °C – 80 °C
Mechanical service life	-
Weight (kg/piece)	0.09      0.21      0.42
Approvals	cULus

Accessories	Article number	Type	PU
Cable markers 4×23mm	499988	LB M8/M12	5
Torque setting tool M8	490090	DM-SET M8	1

### Action chart

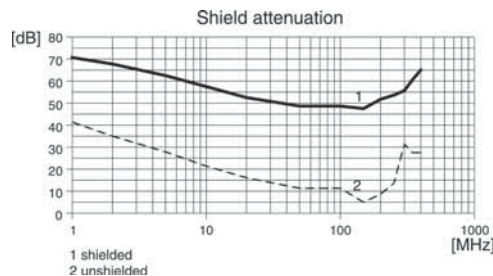

# Actuator sensor interface - M8 – cables

Female M8 straight with PUR cable, open end  
self-locking screwed connection  
c-track compatible, halogen free



### Dimensions

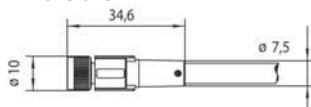

### PIN assignment

481020, 481050, 481100



415020, 415050, 415100



### Circuit diagram

481020, 481050, 481100

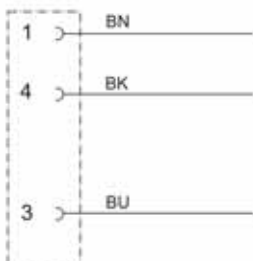

415020, 415050, 415100

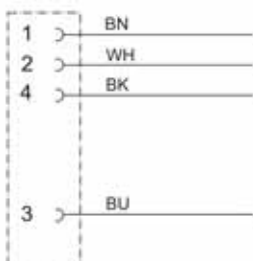

Description	Part-No.	Type	PU	
<b>3-pole</b>				
Cable length (m)	2.0	481020	KUG3-M8 2M-PUR	1
	5.0	481050	KUG3-M8 5M-PUR	1
	10.0	481100	KUG3-M8 10M-PUR	1
<b>4-pole</b>				
Cable length (m)	2.0	415020	KUG4-M8 2M-PUR	1
	5.0	415050	KUG4-M8 5M-PUR	1
	10.0	415100	KUG4-M8 10M-PUR	1
<b>Technical data</b>				
Nominal voltage	3-pole		4-pole	
Nominal voltage range	AC/DC 24 V			
Rated current	max. 30 V			
	4 A			
Pol number	3		4	
Cable length (m)	2.0	5.0	10.0	2.0 5.0 10.0
Status Indication	-			
Current Consumption per LED	-			
Coding	-			
Shielding	-			
<b>General</b>				
Form	M8 × 1, female straight			
Rated insulation voltage (EN 50178)	100 V			
Test voltage	1.5 kV			
Pollution degree	3			
Insulation resistance	>10 <sup>9</sup> Ω			
Contact resistance	< 5 mΩ			
Class of flammability according to UL 94	V0			
Protection class	IP65/IP67/IP68			
Housing material	TPU black			
Contact material	CuSn, gold plated nickel			
Thread material	Zinc die-casting, nickel-plated			
Gasket	NBR			
Cable construction	3 × 0.25mm <sup>2</sup> (32 × 0.1)		4 × 0.25mm <sup>2</sup> (32 × 0.1)	
Cable jacket	PUR black			
Conductor insulation	PP			
Cable diameter	4.4 mm			
Bending radius	10 x cable diameter			
Storage temperature range	-30 °C – 90 °C			
Temperature range connector	-25 °C – 90 °C			
Temperature range cable fixed	-40 °C – 80 °C			
Temperature range cable moving	-25 °C – 80 °C			
Mechanical service life	-			
Weight (kg/piece)	0.05	0.14	0.27	0.07 0.16 0.32
Approvals	cULus			
<b>Accessories</b>				
	<b>Article number</b>	<b>Type</b>	<b>PU</b>	
Cable markers 4×23mm	499988	LB M8/M12	5	
Torque setting tool M8	490090	DM-SET M8	1	

# Actuator sensor interface - M8 – cables

Female M8 straight with PUR cable, shielded 360°, open end self-locking screwed connection  
c-track compatible, halogen free



Description	Part-No.	Type	PU	
<b>3-pole</b>				
Cable length (m)	2.0	458302	KUG3-M8 (C) 2M-PUR	1
	5.0	458305	KUG3-M8 (C) 5M-PUR	1
	10.0	458310	KUG3-M8 (C) 10M-PUR	1
<b>4-pole</b>				
Cable length (m)	2.0	458402	KUG4-M8 (C) 2M-PUR	1
	5.0	458405	KUG4-M8 (C) 5M-PUR	1
	10.0	458410	KUG4-M8 (C) 10M-PUR	1

Technical data	3-pole			4-pole		
Nominal voltage				AC/DC 24 V		
Nominal voltage range				max. 30 V		
Rated current				4 A		
Pol number	3			4		
Cable length (m)	2.0	5.0	10.0	2.0	5.0	10.0
Status Indication				-		
Current Consumption per LED				-		
Coding				-		
Shielding				360°		

## Dimensions

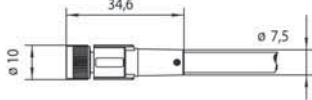

## PIN assignment

458302, 458305, 458310



458402, 458405, 458410



## Circuit diagram

458302, 458305, 458310

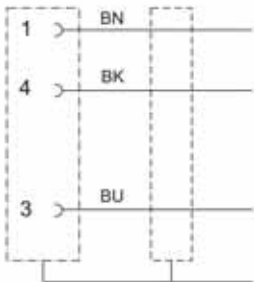

458402, 458405, 458410

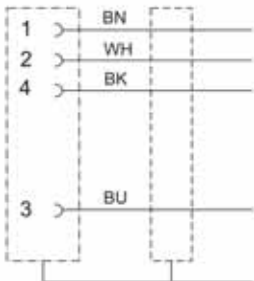

General	
Form	M8 × 1, female straight
Rated insulation voltage (EN 50178)	100 V
Test voltage	1.5 kV
Pollution degree	3
Insulation resistance	>10 <sup>9</sup> Ω
Contact resistance	< 5 mΩ
Class of flammability according to UL 94	V0
Protection class	IP65/IP67
Housing material	TPU black
Contact material	CuSn, gold plated nickel
Thread material	Zinc die-casting, nickel-plated
Gasket	NBR
Cable construction	3 × 0.25mm <sup>2</sup> (32 × 0.1)      4 × 0.25mm <sup>2</sup> (32 × 0.1)
Cable jacket	PUR black
Conductor insulation	PP
Cable diameter	5.0 mm
Bending radius	10 × cable diameter
Storage temperature range	-30 °C – 90 °C
Temperature range connector	-25 °C – 90 °C
Temperature range cable fixed	-40 °C – 80 °C
Temperature range cable moving	-25 °C – 80 °C
Mechanical service life	-
Weight (kg/piece)	0.08    0.19    0.38    0.09    0.21    0.42

Approvals	cULus		
<b>Accessories</b>	<b>Article number</b>	<b>Type</b>	<b>PU</b>
Cable markers 4×23mm	499988	LB M8/M12	5
Torque setting tool M8	490090	DM-SET M8	5

## Action chart

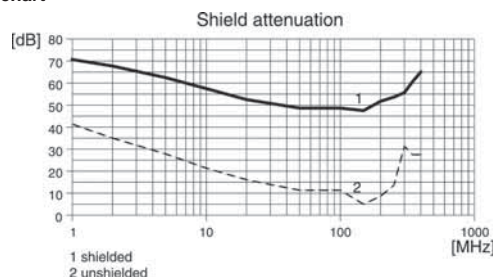



# Actuator sensor interface - M8 – cables

Female M8 angled with PUR cable, open end self-locking screwed connection c-track compatible, halogen free



Description	Part-No.	Type	PU
<b>3-pole</b>			
Cable length (m)	2.0	KUW3-M8 2M-PUR	1
	5.0	KUW3-M8 5M-PUR	1
	10.0	KUW3-M8 10M-PUR	1
<b>4-pole</b>			
Cable length (m)	2.0	KUW4-M8 2M-PUR	1
	5.0	KUW4-M8 5M-PUR	1
	10.0	KUW4-M8 10M-PUR	1

Technical data	3-pole			4-pole		
Nominal voltage				AC/DC 24 V		
Nominal voltage range				max. 30 V		
Rated current				4 A		

Pol number	3			4		
Cable length (m)	2.0	5.0	10.0	2.0	5.0	10.0
Status Indication	-					
Current Consumption per LED	-					
Coding	-					
Shielding	-					

General	
Form	M8 × 1, female angled
Rated insulation voltage (EN 50178)	100 V
Test voltage	1.5 kV
Pollution degree	3
Insulation resistance	>10 <sup>9</sup> Ω
Contact resistance	< 5 mΩ
Class of flammability according to UL 94	V0
Protection class	IP65/IP67/IP68
Housing material	TPU black
Contact material	CuSn, gold plated nickel
Thread material	Zinc die-casting, nickel-plated
Gasket	NBR
Cable construction	3 × 0.25mm <sup>2</sup> (32 × 0.1)      4 × 0.25mm <sup>2</sup> (32 × 0.1)
Cable jacket	PUR black
Conductor insulation	PP
Cable diameter	4.4 mm
Bending radius	10 × cable diameter
Storage temperature range	-30 °C – 90 °C
Temperature range connector	-25 °C – 90 °C
Temperature range cable fixed	-40 °C – 80 °C
Temperature range cable moving	-25 °C – 80 °C
Mechanical service life	-
Weight (kg/piece)	0.05    0.14    0.26    0.06    0.16    0.31
Approvals	cULus

Accessories	Article number	Type	PU
Cable markers 4×23mm	499988	LB M8/M12	5
Torque setting tool M8	490090	DM-SET M8	1

## Dimensions

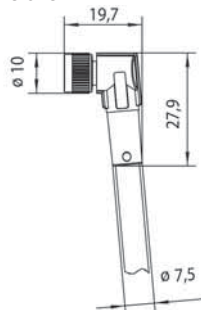

## PIN assignment

474020, 474050, 474100



416020, 416050, 416100



## Circuit diagram

474020, 474050, 474100

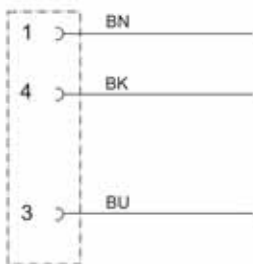

416020, 416050, 416100

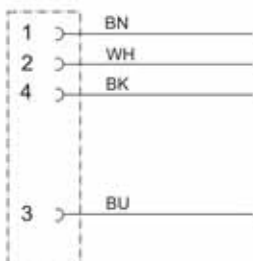

# Actuator sensor interface - M8 – cables

Female M8 angled with PUR cable, shielded 360°, open end self-locking screwed connection c-track compatible, halogen free



Description	Part-No.	Type	PU
<b>3-pole</b>			
Cable length (m)	2.0	KUW3-M8 (C) 2M-PUR	1
	5.0	KUW3-M8 (C) 5M-PUR	1
	10.0	KUW3-M8 (C) 10M-PUR	1
<b>4-pole</b>			
Cable length (m)	2.0	KUW4-M8 (C) 2M-PUR	1
	5.0	KUW4-M8 (C) 5M-PUR	1
	10.0	KUW4-M8 (C) 10M-PUR	1

Technical data	3-pole	4-pole
Nominal voltage		AC/DC 24 V
Nominal voltage range		max. 30 V
Rated current		4 A

Pol number	3	4
Cable length (m)	2.0 5.0 10.0	2.0 5.0 10.0
Status Indication		-
Current Consumption per LED		-
Coding		-
Shielding		360°

General	
Form	M8 × 1, female angled
Rated insulation voltage (EN 50178)	100 V
Test voltage	1.5 kV
Pollution degree	3
Insulation resistance	>10 <sup>9</sup> Ω
Contact resistance	< 5 mΩ
Class of flammability according to UL 94	V0
Protection class	IP65/IP67
Housing material	TPU black
Contact material	CuSn, gold plated nickel
Thread material	Zinc die-casting, nickel-plated
Gasket	NBR
Cable construction	3 × 0.25mm <sup>2</sup> (32 × 0.1) 4 × 0.25mm <sup>2</sup> (32 × 0.1)
Cable jacket	PUR black
Conductor insulation	PP
Cable diameter	5.0 mm
Bending radius	10 × cable diameter
Storage temperature range	-30 °C – 90 °C
Temperature range connector	-25 °C – 90 °C
Temperature range cable fixed	-40 °C – 80 °C
Temperature range cable moving	-25 °C – 80 °C
Mechanical service life	-
Weight (kg/piece)	0.08 0.20 0.39 0.09 0.21 0.40
Approvals	cULus

Accessories	Article number	Type	PU
Cable markers 4×23mm	499988	LB M8/M12	5
Torque setting tool M8	490090	DM-SET M8	1

### Action chart

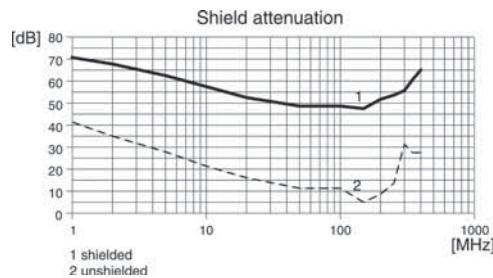

### Dimensions

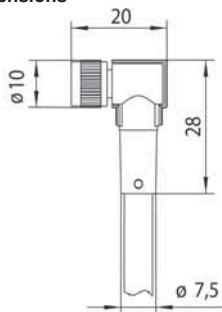

### PIN assignment

458502, 458505, 458510



458602, 458605, 458610



### Circuit diagram

458502, 458505, 458510

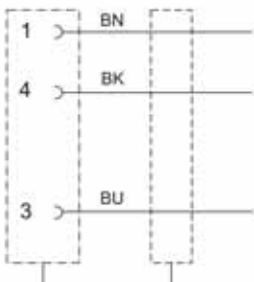

458602, 458605, 458610

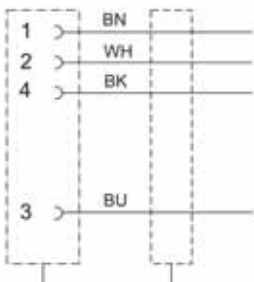

# Actuator sensor interface - M8 – cables

Female M8 angled with 2 LED's and PUR cable, open end  
self-locking screwed connection  
c-track compatible, halogen free



### Dimensions

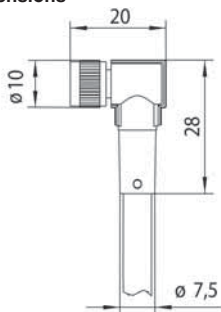

### PIN assignment



### Circuit diagram

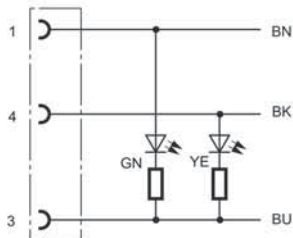

Description	Part-No.	Type	PU
<b>3-pole</b>			
Cable length (m)	2.0	KUW/LED A-M8 2M-PUR	1
	5.0	KUW/LED A-M8 5M-PUR	1
	10.0	KUW/LED A-M8 10M-PUR	1

Technical data		3-pole	
Nominal voltage		DC 24 V	
Nominal voltage range		DC 10 - 28 V	
Rated current		4 A	
Pol number		3	
Cable length (m)	2.0	5.0	10.0
Status Indication	Operating voltage: LED green, I/O:LED yellow		
Current Consumption per LED	< 10 mA / LED		
Coding	-		
Shielding	-		

General				
Form	M8 × 1, female angled, with 2 LEDs			
Rated insulation voltage (EN 50178)	32 V			
Test voltage	-			
Pollution degree	3			
Insulation resistance	>10 <sup>9</sup> Ω			
Contact resistance	< 5 mΩ			
Class of flammability according to UL 94	V0			
Protection class	IP65/IP67/IP68			
Housing material	TPU transparent			
Contact material	CuSn, gold plated nickel			
Thread material	Zinc die-casting, nickel-plated			
Gasket	NBR			
Cable construction	3 × 0.25mm <sup>2</sup> (32 × 0.1)			
Cable jacket	PUR black			
Conductor insulation	PP			
Cable diameter	4.4 mm			
Bending radius	10 × cable diameter			
Storage temperature range	-30 °C – 90 °C			
Temperature range connector	-25 °C – 90 °C			
Temperature range cable fixed	-40 °C – 80 °C			
Temperature range cable moving	-25 °C – 80 °C			
Mechanical service life	-			
Weight (kg/piece)	0.05	0.14	0.27	
Approvals	cULus			
Accessories		Article number	Type	PU
Cable markers 4×23mm		499988	LB M8/M12	5
Torque setting tool M8		490090	DM-SET M8	1

# Actuator sensor interface - M8 / M8 – cables

Male M8 straight to female M8 straight with PUR cable  
self-locking screwed connection  
c-track compatible, halogen free



## Dimensions

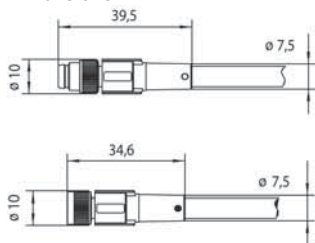

## PIN assignment

487003, 487006, 487010, 487015,  
487020, 487050

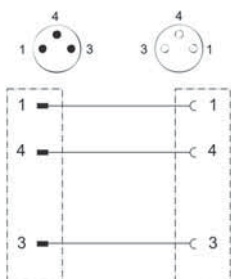

410003, 410006, 410010, 410015,  
410020, 410050

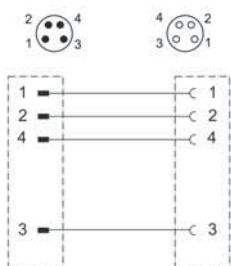

Description	Part-No.	Type	PU	
<b>3-pole</b>				
Cable length (m)	0.3	487003	STG3-M8/KUG3-M8 0,3M-PUR	1
	0.6	487006	STG3-M8/KUG3-M8 0,6M-PUR	1
	1.0	487010	STG3-M8/KUG3-M8 1,0M-PUR	1
	1.5	487015	STG3-M8/KUG3-M8 1,5M-PUR	1
	2.0	487020	STG3-M8/KUG3-M8 2,0M-PUR	1
	5.0	487050	STG3-M8/KUG3-M8 5,0M-PUR	1
<b>4-pole</b>				
Cable length (m)	0.3	410003	STG4-M8/KUG4-M8 0,3M-PUR	1
	0.6	410006	STG4-M8/KUG4-M8 0,6M-PUR	1
	1.0	410010	STG4-M8/KUG4-M8 1,0M-PUR	1
	1.5	410015	STG4-M8/KUG4-M8 1,5M-PUR	1
	2.0	410020	STG4-M8/KUG4-M8 2,0M-PUR	1
	5.0	410050	STG4-M8/KUG4-M8 5,0M-PUR	1

Technical data	3-pole					4-pole						
Nominal voltage	AC/DC 24 V											
Nominal voltage range	max. 60 V					max. 30 V						
Rated current	4 A											
Pol number	3					4						
Cable length (m)	0.3	0.6	1.0	1.5	2.0	5.0	0.3	0.6	1.0	1.5	2.0	5.0
Status Indication	-											
Current Consumption per LED	-											
Coding	-											
Shielding	-											

General														
Form	M8 × 1, male straight / M8 × 1, female straight													
Rated insulation voltage (EN 50178)	100 V													
Test voltage	1.5 kV													
Pollution degree	3													
Insulation resistance	>10 <sup>9</sup> Ω													
Contact resistance	<5 mΩ													
Class of flammability according to UL 94	V0													
Protection class	IP65/IP67/IP68													
Housing material	TPU black													
Contact material	CuSn, gold plated nickel													
Thread material	Zinc die-casting, nickel-plated													
Gasket	NBR													
Cable construction	3 × 0.25 mm <sup>2</sup> (32 × 0.1)					4 × 0.25 mm <sup>2</sup> (32 × 0.1)								
Cable jacket	PUR black													
Conductor insulation	PP													
Cable diameter	4.4 mm													
Bending radius	10 × cable diameter													
Storage temperature range	-30 °C – 90 °C													
Temperature range connector	-25 °C – 90 °C													
Temperature range cable fixed	-40 °C – 80 °C													
Temperature range cable moving	-25 °C – 80 °C													
Mechanical service life	-													
Weight (kg/piece)	0.02	0.03	0.04	0.05	0.06	0.16	0.05	0.06	0.08	0.10	0.13	0.31		
Approvals	cULus													
Accessories														
Cable markers 4×23mm	499988					Type			LB M8/M12					5
Torque setting tool M8	490090					Type			DM-SET M8					1

# Actuator sensor interface - M8 / M8 – cables

Male M8 straight to female M8 angled with PUR cable  
self-locking screwed connection  
c-track compatible, halogen free



### Dimensions

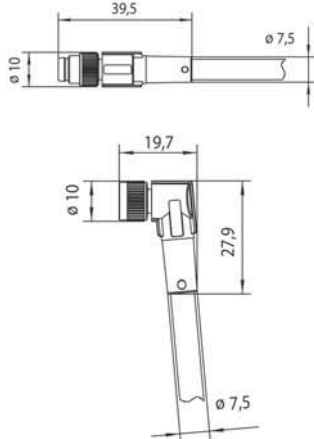

### PIN assignment

488003, 488006, 488010, 488015,  
488020, 488050

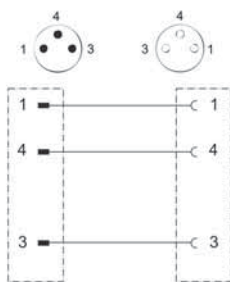

411003, 411006, 411010, 411015,  
411020, 411050

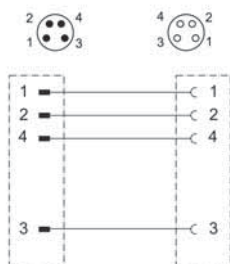

Description	Part-No.	Type	PU	
<b>3-pole</b>				
Cable length (m)	0.3	488003	STG3-M8/KUW3-M8 0,3M-PUR	1
	0.6	488006	STG3-M8/KUW3-M8 0,6M-PUR	1
	1.0	488010	STG3-M8/KUW3-M8 1,0M-PUR	1
	1.5	488015	STG3-M8/KUW3-M8 1,5M-PUR	1
	2.0	488020	STG3-M8/KUW3-M8 2,0M-PUR	1
	5.0	488050	STG3-M8/KUW3-M8 5,0M-PUR	1
<b>4-pole</b>				
Cable length (m)	0.3	411003	STG4-M8/KUW4-M8 0,3M-PUR	1
	0.6	411006	STG4-M8/KUW4-M8 0,6M-PUR	1
	1.0	411010	STG4-M8/KUW4-M8 1,0M-PUR	1
	1.5	411015	STG4-M8/KUW4-M8 1,5M-PUR	1
	2.0	411020	STG4-M8/KUW4-M8 2,0M-PUR	1
	5.0	411050	STG4-M8/KUW4-M8 5,0M-PUR	1

Technical data	3-pole					4-pole						
Nominal voltage	AC/DC 24 V											
Nominal voltage range	max. 60 V					max. 30 V						
Rated current	4 A											
Pol number	3					4						
Cable length (m)	0.3	0.6	1.0	1.5	2.0	5.0	0.3	0.6	1.0	1.5	2.0	5.0
Status Indication	-											
Current Consumption per LED	-											
Coding	-											
Shielding	-											

General	
Form	M8 × 1, male straight / M8 × 1, female angled
Rated insulation voltage (EN 50178)	100 V
Test voltage	1.5 kV
Pollution degree	3
Insulation resistance	>10 <sup>9</sup> Ω
Contact resistance	<5 mΩ
Class of flammability according to UL 94	V0
Protection class	IP65/IP67/IP68
Housing material	TPU black
Contact material	CuSn, gold plated nickel
Thread material	Zinc die-casting, nickel-plated
Gasket	NBR
Cable construction	3 × 0.25 mm <sup>2</sup> (32 × 0.1)      4 × 0.25 mm <sup>2</sup> (32 × 0.1)
Cable jacket	PUR black
Conductor insulation	PP
Cable diameter	4.4 mm
Bending radius	10 × cable diameter
Storage temperature range	-30 °C – 90 °C
Temperature range connector	-25 °C – 90 °C
Temperature range cable fixed	-40 °C – 80 °C
Temperature range cable moving	-25 °C – 80 °C
Mechanical service life	-
Weight (kg/piece)	0.02   0.03   0.04   0.05   0.06   0.16   0.05   0.06   0.08   0.10   0.13   0.31
Approvals	cULus

Accessories	Article number	Type	PU
Cable Markers 4×23mm	499988	LB M8/M12	5
Torque setting tool M8	490090	DM-SET M8	1

# Actuator sensor interface - M12 - cables

Male M12 straight with PUR cable, open end  
self-locking screwed connection  
c-track compatible, halogen free



Description	Part-No.	Type	PU	
<b>3-pole</b>				
Cable length (m)	2.0	471020	STG3-M12 2M-PUR	1
	5.0	471050	STG3-M12 5M-PUR	1
	10.0	471100	STG3-M12 10M-PUR	1
<b>4-pole</b>				
Cable length (m)	2.0	472020	STG4-M12 2M-PUR	1
	5.0	472050	STG4-M12 5M-PUR	1
	10.0	472100	STG4-M12 10M-PUR	1

Technical data	3-pole	4-pole
Nominal voltage	AC/DC 24 V	
Nominal voltage range	max. 250 V	
Rated current	4 A	

Pol number	3	4				
Cable length (m)	2.0	5.0	10.0	2.0	5.0	10.0
Status Indication	-					
Current Consumption per LED	-					
Coding	A					
Shielding	-					

General	
Form	M12 × 1, male straight
Rated insulation voltage (EN 50178)	250 V
Test voltage	2.5 kV
Pollution degree	3
Insulation resistance	>10 <sup>9</sup> Ω
Contact resistance	<5 mΩ
Class of flammability according to UL 94	V0
Protection class	IP65/IP67/IP68
Housing material	TPU black
Contact material	CuSn, gold plated nickel
Thread material	Zinc die-casting, nickel-plated
Gasket	-
Cable construction	3 × 0.34 mm <sup>2</sup> (42 × 0.1)      4 × 0.34 mm <sup>2</sup> (42 × 0.1)
Cable jacket	PUR black
Conductor insulation	PP
Cable diameter	4.4 mm      4.7 mm
Bending radius	10 × cable diameter
Storage temperature range	-30 °C – 90 °C
Temperature range connector	-25 °C – 90 °C
Temperature range cable fixed	-40 °C – 80 °C
Temperature range cable moving	-25 °C – 80 °C
Mechanical service life	-
Weight (kg/piece)	0.090    0.190    0.380    0.100    0.200    0.400
Approvals	cULus

Accessories	Article number	Type	PU
Cable markers 4×23mm	499988	LB M8/M12	5
Torque setting tool M12	490091	DM-SET M12	1

## Dimensions

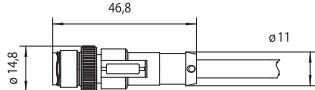

## PIN assignment

471020, 471050, 471100



472020, 472050, 472100



## Circuit diagram

471020, 471050, 471100

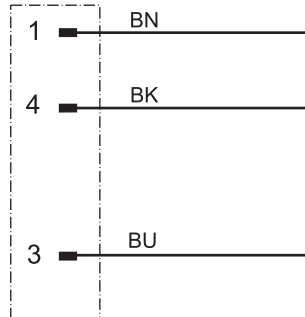

472020, 472050, 472100

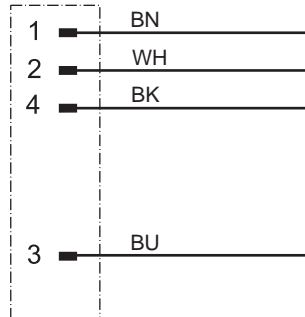

# Actuator sensor interface - M12 - cables

Male M12 straight with PUR cable, open end  
self-locking screwed connection  
c-track compatible, halogen free



### Dimensions

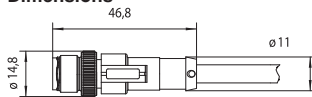

### PIN assignment

473020, 473050, 473100



482020, 482050, 482100

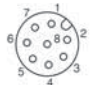

### Circuit diagram

473020, 473050, 473100

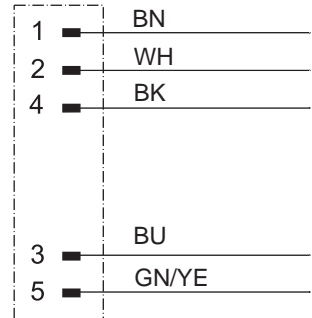

482020, 482050, 482100

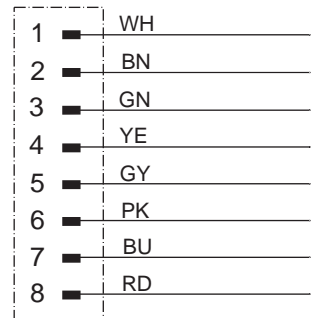

Description	Part-No.	Type	PU	
<b>5-pole</b>				
Cable length (m)	2.0	473020	STG5-M12 2M-PUR	1
	5.0	473050	STG5-M12 5M-PUR	1
	10.0	473100	STG5-M12 10M-PUR	1
<b>8-pole</b>				
Cable length (m)	2.0	482020	STG8-M12 2M-PUR	1
	5.0	482050	STG8-M12 5M-PUR	1
	10.0	482100	STG8-M12 10M-PUR	1

Technical data	5-pole			8-pole		
Nominal voltage	AC/DC 24 V					
Nominal voltage range	max. 60 V			max. 30 V		
Rated current	4 A			2 A		
Pol number	5			8		
Cable length (m)	2.0	5.0	10.0	2.0	5.0	10.0
Status Indication	-					
Current Consumption per LED	-					
Coding	A					
Shielding	-					
<b>General</b>						
Form	M12 × 1, male straight					
Rated insulation voltage (EN 50178)	63 V			36 V		
Test voltage	1.5 kV					
Pollution degree	3					
Insulation resistance	>10 <sup>9</sup> Ω					
Contact resistance	<5 mΩ					
Class of flammability according to UL 94	V0					
Protection class	IP65/IP67/IP68					
Housing material	TPU black					
Contact material	CuSn, gold plated nickel					
Thread material	Zinc die-casting, nickel-plated					
Gasket	-					
Cable construction	5 × 0.34 mm <sup>2</sup> (42 × 0.1)			8 × 0.25 mm <sup>2</sup> (32 × 0.1)		
Cable jacket	PUR black					
Conductor insulation	PP					
Cable diameter	5.0 mm			5.9 mm		
Bending radius	10 × cable diameter					
Storage temperature range	-30 °C – 90 °C					
Temperature range connector	-25 °C – 90 °C					
Temperature range cable fixed	-40 °C – 80 °C					
Temperature range cable moving	-25 °C – 80 °C					
Mechanical service life	-					
Weight (kg/piece)	0.100	0.250	0.480	0.110	0.260	0.525
Approvals	cULus					
<b>Accessories</b>						
	Article number		Type		PU	
Cable markers 4×23mm	499988		LB M8/M12		5	
Torque setting tool M12	490091		DM-SET M12		1	

# Actuator sensor interface - M12 - cables

Male M12 straight with PUR cable, shielded 360°, open end self-locking screwed connection  
c-track compatible, halogen free



### Dimensions

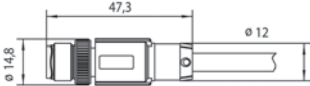

### PIN assignment



### Circuit diagram

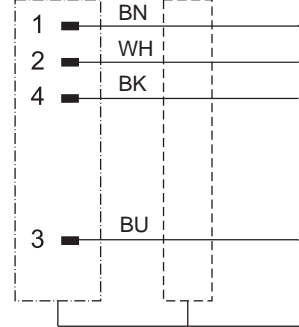

Description	Part-No.	Type	PU	
<b>4-pole</b>				
Cable length (m)	2.0	456102	STG4-M12 (C) 2M-PUR	1
	5.0	456105	STG4-M12 (C) 5M-PUR	1
	10.0	456110	STG4-M12 (C) 10M-PUR	1

Technical data		4-pole	
Nominal voltage		AC/DC 24 V	
Nominal voltage range		max. 250 V	
Rated current		4 A	
Pol number		4	
Cable length (m)	2.0	5.0	10.0
Status Indication		-	
Current Consumption per LED		-	
Coding		A	
Shielding		-	

General		M12 × 1, male straight	
Form		M12 × 1, male straight	
Rated insulation voltage (EN 50178)		250 V	
Test voltage		2.5 kV	
Pollution degree		3	
Insulation resistance		>10 <sup>9</sup> Ω	
Contact resistance		<5 mΩ	
Class of flammability according to UL 94		V0	
Protection class		IP65/IP67	
Housing material		TPU black	
Contact material		CuSn, gold plated nickel	
Thread material		Zinc die-casting, nickel-plated	
Gasket		-	
Cable construction		4 × 0.34 mm <sup>2</sup> (42 × 0.1)	
Cable jacket		PUR black	
Conductor insulation		PP	
Cable diameter		5.9 mm	
Bending radius		10 × cable diameter	
Storage temperature range		-30 °C – 90 °C	
Temperature range connector		-25 °C – 90 °C	
Temperature range cable fixed		-40 °C – 80 °C	
Temperature range cable moving		-25 °C – 80 °C	
Mechanical service life		-	
Weight (kg/piece)	0.125	0.275	0.520
Approvals		cULus	

Accessories	Article number	Type	PU
Cable markers 4×23mm	499988	LB M8/M12	5
Torque setting tool M12	490091	DM-SET M12	1

### Action chart

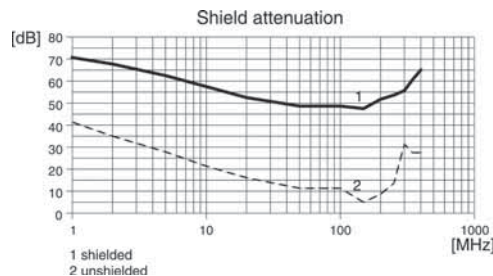



# Actuator sensor interface - M12 - cables

Male M12 straight with PUR cable, shielded 360°, open end self-locking screwed connection  
c-track compatible, halogen free



### Dimensions

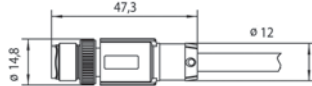

### PIN assignment

456202, 456205, 456210



458702, 458705, 458710

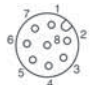

### Circuit diagram

456202, 456205, 456210

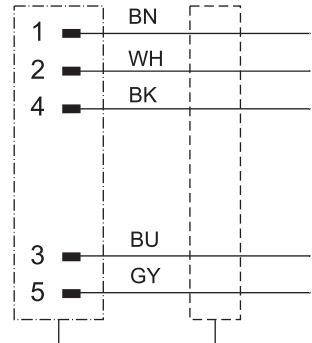

458702, 458705, 458710

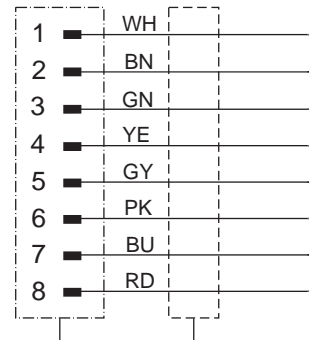

Description	Part-No.	Type	PU	
<b>5-pole</b>				
Cable length (m)	2.0	456202	STG5-M12 (C) 2M-PUR	1
	5.0	456205	STG5-M12 (C) 5M-PUR	1
	10.0	456210	STG5-M12 (C) 10M-PUR	1
<b>8-pole</b>				
Cable length (m)	2.0	458702	STG8-M12 (C) 2M-PUR	1
	5.0	458705	STG8-M12 (C) 5M-PUR	1
	10.0	458710	STG8-M12 (C) 10M-PUR	1

Technical data	5-pole			8-pole		
	AC/DC 24 V					
Nominal voltage	max. 60 V			max. 30 V		
Rated current	4 A			2 A		
Pol number	5			8		
Cable length (m)	2.0	5.0	10.0	2.0	5.0	10.0
Status Indication	-					
Current Consumption per LED	-					
Coding	A					
Shielding	-					

General						
Form	M12 × 1, male straight					
Rated insulation voltage (EN 50178)	63 V			36 V		
Test voltage	1.5 kV					
Pollution degree	3					
Insulation resistance	>10 <sup>9</sup> Ω					
Contact resistance	<5 mΩ					
Class of flammability according to UL 94	V0					
Protection class	IP65/IP67					
Housing material	TPU black					
Contact material	CuSn, gold plated nickel					
Thread material	Zinc die-casting, nickel-plated					
Gasket	-					
Cable construction	5 × 0.34 mm <sup>2</sup> (42 × 0.1)			8 × 0.25 mm <sup>2</sup> (32 × 0.1)		
Cable jacket	PUR black					
Conductor insulation	PP					
Cable diameter	5.9 mm					
Bending radius	10 × cable diameter					
Storage temperature range	-30 °C – 90 °C					
Temperature range connector	-25 °C – 90 °C					
Temperature range cable fixed	-40 °C – 80 °C					
Temperature range cable moving	-25 °C – 80 °C					
Mechanical service life	-					
Weight (kg/piece)	0.150	0.300	0.565	0.155	0.305	0.570

Approvals			
cULus			
Accessories			
Article number	Type	PU	
Cable markers 4×23mm	499988	LB M8/M12	5
Torque setting tool M12	490091	DM-SET M12	1

### Action chart

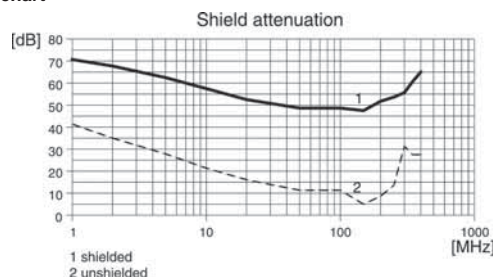

# Actuator sensor interface - M12 - cables

Female M12 straight with PUR cable, open end  
self-locking screwed connection  
c-track compatible, halogen free



## Dimensions

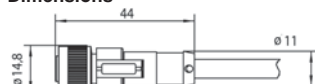

## PIN assignment

465020, 465050, 465100



466020, 466050, 466100



## Circuit diagram

465020, 465050, 465100

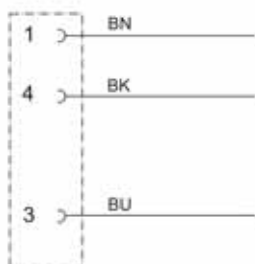

466020, 466050, 466100

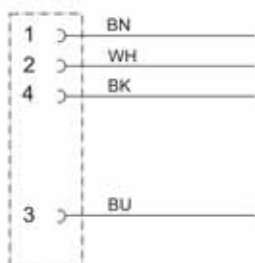

Description	Part-No.	Type	PU			
<b>3-pole</b>						
Cable length (m)	2.0	465020	KUG3-M12 2M-PUR	1		
	5.0	465050	KUG3-M12 5M-PUR	1		
	10.0	465100	KUG3-M12 10M-PUR	1		
<b>4-pole</b>						
Cable length (m)	2.0	466020	KUG4-M12 2M-PUR	1		
	5.0	466050	KUG4-M12 5M-PUR	1		
	10.0	466100	KUG4-M12 10M-PUR	1		
<b>Technical data</b>						
	<b>3-pole</b>		<b>4-pole</b>			
Nominal voltage	AC/DC 24 V					
Nominal voltage range	max. 250 V					
Rated current	4 A					
Pol number	3		4			
Cable length (m)	2.0	5.0	10.0	2.0	5.0	10.0
Status Indication	-					
Current Consumption per LED	-					
Coding	A					
Shielding	-					
<b>General</b>						
Form	M12 × 1, female straight					
Rated insulation voltage (EN 50178)	250 V					
Test voltage	2.5 kV					
Pollution degree	3					
Insulation resistance	>10 <sup>9</sup> Ω					
Contact resistance	<5 mΩ					
Class of flammability according to UL 94	V0					
Protection class	IP65/IP67/IP68					
Housing material	TPU black					
Contact material	CuSn, gold plated nickel					
Thread material	Zinc die-casting, nickel-plated					
Gasket	-					
Cable construction	3 × 0.34 mm <sup>2</sup> (42 × 0.1)			4 × 0.34 mm <sup>2</sup> (42 × 0.1)		
Cable jacket	PUR black					
Conductor insulation	PP					
Cable diameter	4.4 mm			4.7 mm		
Bending radius	10 × cable diameter					
Storage temperature range	-30 °C – 90 °C					
Temperature range connector	-25 °C – 90 °C					
Temperature range cable fixed	-40 °C – 80 °C					
Temperature range cable moving	-25 °C – 80 °C					
Mechanical service life	-					
Weight (kg/piece)	0.090	0.190	0.380	0.100	0.200	0.400
Approvals	cULus					
<b>Accessories</b>						
	<b>Article number</b>		<b>Type</b>		<b>PU</b>	
Cable markers 4×23mm	499988		LB M8/M12		5	
Torque setting tool M12	490091		DM-SET M12		1	

# Actuator sensor interface - M12 - cables

Female M12 straight with PUR cable, open end  
self-locking screwed connection  
c-track compatible, halogen free



### Dimensions

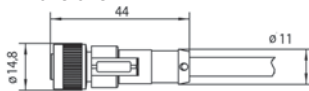

### PIN assignment

477020, 477050, 477100



478020, 478050, 478100



### Circuit diagram

477020, 477050, 477100

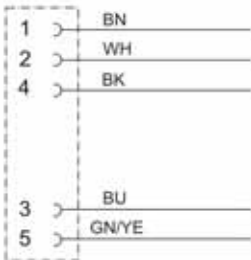

478020, 478050, 478100

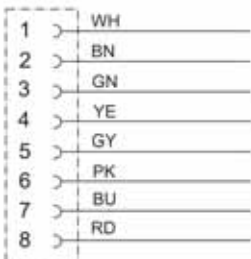

Description	Part-No.	Type	PU	
<b>5-pole</b>				
Cable length (m)	2.0	477020	KUG5-M12 2M-PUR	1
	5.0	477050	KUG5-M12 5M-PUR	1
	10.0	477100	KUG5-M12 10M-PUR	1
<b>8-pole</b>				
Cable length (m)	2.0	478020	KUG8-M12 2M-PUR	1
	5.0	478050	KUG8-M12 5M-PUR	1
	10.0	478100	KUG8-M12 10M-PUR	1

Technical data	5-pole			8-pole		
	AC/DC 24 V					
Nominal voltage	AC/DC 24 V					
Nominal voltage range	max. 60 V			max. 30 V		
Rated current	4 A			2 A		
Pol number	5			8		
Cable length (m)	2.0	5.0	10.0	2.0	5.0	10.0
Status Indication	-					
Current Consumption per LED	-					
Coding	A					
Shielding	-					

General						
Form	M12 × 1, female straight					
Rated insulation voltage (EN 50178)	63 V			36 V		
Test voltage	1.5 kV					
Pollution degree	3					
Insulation resistance	>10 <sup>9</sup> Ω					
Contact resistance	<5 mΩ					
Class of flammability according to UL 94	V0					
Protection class	IP65/IP67/IP68					
Housing material	TPU black					
Contact material	CuSn, gold plated nickel					
Thread material	Zinc die-casting, nickel-plated					
Gasket	-					

Cable construction	5 × 0.34 mm <sup>2</sup> (42 × 0.1)			8 × 0.25 mm <sup>2</sup> (32 × 0.1)		
Cable jacket	PUR black					
Conductor insulation	PP					
Cable diameter	5.0 mm			5.9 mm		
Bending radius	10 × cable diameter					
Storage temperature range	-30 °C – 90 °C					
Temperature range connector	-25 °C – 90 °C					
Temperature range cable fixed	-40 °C – 80 °C					
Temperature range cable moving	-25 °C – 80 °C					
Mechanical service life	-					
Weight (kg/piece)	0.100	0.250	0.480	0.110	0.260	0.525
Approvals	cULus					

Accessories	Article number	Type	PU
Cable markers 4×23mm	499988	LB M8/M12	5
Torque setting tool M12	490091	DM-SET M12	1

# Actuator sensor interface - M12 - cables

Female M12 straight with PUR cable, shielded 360°, open end self-locking screwed connection  
c-track compatible, halogen free



### Dimensions

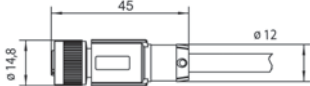

### PIN assignment



### Circuit diagram

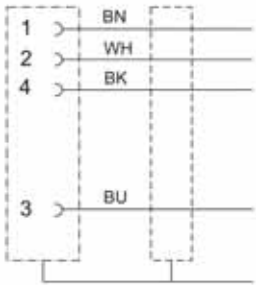

Description	Part-No.	Type	PU
<b>4-pole</b>			
Cable length (m)	2.0	KUG4-M12 (C) 2M-PUR	1
	5.0	KUG4-M12 (C) 5M-PUR	1
	10.0	KUG4-M12 (C) 10M-PUR	1

Technical data		4-pole	
Nominal voltage		AC/DC 24 V	
Nominal voltage range		max. 250 V	
Rated current		4 A	
Pol number		4	
Cable length (m)	2.0	5.0	10.0
Status Indication		-	
Current Consumption per LED		-	
Coding		A	
Shielding		-	

General		M12 × 1, female straight	
Form		M12 × 1, female straight	
Rated insulation voltage (EN 50178)		250 V	
Test voltage		2.5 kV	
Pollution degree		3	
Insulation resistance		>10 <sup>9</sup> Ω	
Contact resistance		<5 mΩ	
Class of flammability according to UL 94		V0	
Protection class		IP65/IP67	
Housing material		TPU black	
Contact material		CuSn, gold plated nickel	
Thread material		Zinc die-casting, nickel-plated	
Gasket		-	
Cable construction		4 × 0.34 mm <sup>2</sup> (42 × 0.1)	
Cable jacket		PUR black	
Conductor insulation		PP	
Cable diameter		5.9 mm	
Bending radius		10 × cable diameter	
Storage temperature range		-30 °C – 90 °C	
Temperature range connector		-25 °C – 90 °C	
Temperature range cable fixed		-40 °C – 80 °C	
Temperature range cable moving		-25 °C – 80 °C	
Mechanical service life		-	
Weight (kg/piece)	0.125	0.275	0.520
Approvals		cULus	

Accessories	Article number	Type	PU
Cable markers 4×23mm	499988	LB M8/M12	5
Torque setting tool M12	490091	DM-SET M12	1

### Action chart

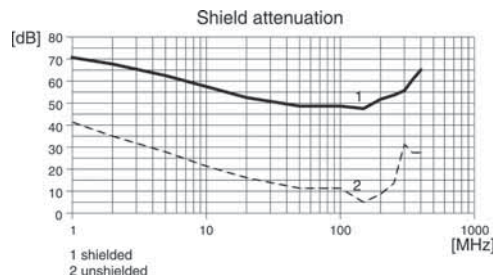

# Actuator sensor interface - M12 - cables

Female M12 straight with PUR cable, shielded 360°, open end self-locking screwed connection  
c-track compatible, halogen free



### Dimensions

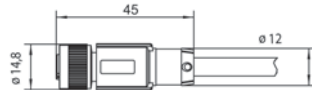

### PIN assignment

456502, 456505, 456510

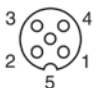

458802, 458805, 458810

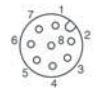

### Circuit diagram

456502, 456505, 456510

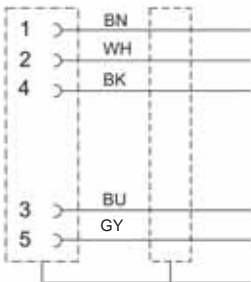

458802, 458805, 458810

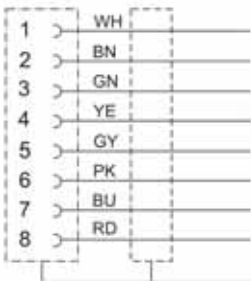

Description	Part-No.	Type	PU	
<b>5-pole</b>				
Cable length (m)	2.0	456502	KUG5-M12 (C) 2M-PUR	1
	5.0	456505	KUG5-M12 (C) 5M-PUR	1
	10.0	456510	KUG5-M12 (C) 10M-PUR	1
<b>8-pole</b>				
Cable length (m)	2.0	458802	KUG8-M12 (C) 2M-PUR	1
	5.0	458805	KUG8-M12 (C) 5M-PUR	1
	10.0	458810	KUG8-M12 (C) 10M-PUR	1

Technical data	5-pole			8-pole		
	AC/DC 24 V					
Nominal voltage	AC/DC 24 V					
Nominal voltage range	max. 60 V			max. 30 V		
Rated current	4 A			2 A		
Pol number	5			8		
Cable length (m)	2.0	5.0	10.0	2.0	5.0	10.0
Status Indication	-					
Current Consumption per LED	-					
Coding	A					
Shielding	-					

General						
Form	M12 × 1, female straight					
Rated insulation voltage (EN 50178)	63 V			36 V		
Test voltage	1.5 kV					
Pollution degree	3					
Insulation resistance	>10 <sup>9</sup> Ω					
Contact resistance	<5 mΩ					
Class of flammability according to UL 94	V0					
Protection class	IP65/IP67					
Housing material	TPU black					
Contact material	CuSn, gold plated nickel					
Thread material	Zinc die-casting, nickel-plated					
Gasket	-					
Cable construction	5 × 0.34 mm <sup>2</sup> (42 × 0.1)			8 × 0.25 mm <sup>2</sup> (32 × 0.1)		
Cable jacket	PUR black					
Conductor insulation	PP					
Cable diameter	5.9 mm					
Bending radius	10 × cable diameter					
Storage temperature range	-30 °C – 90 °C					
Temperature range connector	-25 °C – 90 °C					
Temperature range cable fixed	-40 °C – 80 °C					
Temperature range cable moving	-25 °C – 80 °C					
Mechanical service life	-					
Weight (kg/piece)	0.150	0.300	0.565	0.150	0.305	0.570
Approvals	cULus					

Accessories	Article number	Type	PU
Cable markers 4×23mm	499988	LB M8/M12	5
Torque setting tool M12	490091	DM-SET M12	1

### Action chart

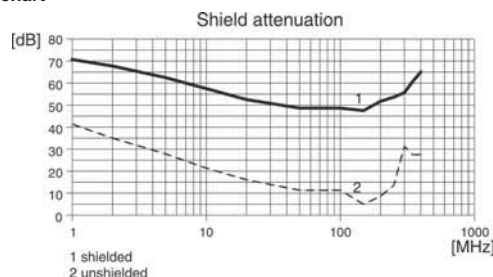

# Actuator sensor interface - M12 - cables

Female M12 angled with PUR cable, open end  
self-locking screwed connection  
c-track compatible, halogen free



Description	Part-No.	Type	PU
<b>3-pole</b>			
Cable length (m)	2.0	KUW3-M12 2M-PUR	1
	5.0	KUW3-M12 5M-PUR	1
	10.0	KUW3-M12 10M-PUR	1
<b>4-pole</b>			
Cable length (m)	2.0	KUW4-M12 2M-PUR	1
	5.0	KUW4-M12 5M-PUR	1
	10.0	KUW4-M12 10M-PUR	1

Technical data	3-pole			4-pole		
Nominal voltage				AC/DC 24 V		
Nominal voltage range				max. 250 V		
Rated current				4 A		
Pol number	3			4		
Cable length (m)	2.0	5.0	10.0	2.0	5.0	10.0
Status Indication				-		
Current Consumption per LED				-		
Coding				A		
Shielding				-		

General	
Form	M12 × 1, female angled
Rated insulation voltage (EN 50178)	250 V
Test voltage	2.5 kV
Pollution degree	3
Insulation resistance	>10 <sup>9</sup> Ω
Contact resistance	<5 mΩ
Class of flammability according to UL 94	V0
Protection class	IP65/IP67/IP68
Housing material	TPU black
Contact material	CuSn, gold plated nickel
Thread material	Zinc die-casting, nickel-plated
Gasket	NBR
Cable construction	3 × 0.34 mm <sup>2</sup> (42 × 0.1)      4 × 0.34 mm <sup>2</sup> (42 × 0.1)
Cable jacket	PUR black
Conductor insulation	PP
Cable diameter	4.4 mm      4.7 mm
Bending radius	10 × cable diameter
Storage temperature range	-30 °C – 90 °C
Temperature range connector	-25 °C – 90 °C
Temperature range cable fixed	-40 °C – 80 °C
Temperature range cable moving	-25 °C – 80 °C
Mechanical service life	-
Weight (kg/piece)	0.090    0.190    0.380    0.100    0.200    0.400
Approvals	cULus

Accessories	Article number	Type	PU
Cable markers 4×23mm	499988	LB M8/M12	5
Torque setting tool M12	490091	DM-SET M12	1

## Dimensions

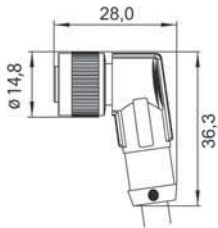

## PIN assignment

462020, 462050, 462100



464020, 464050, 464100



## Circuit diagram

462020, 462050, 462100

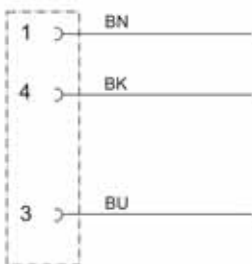

464020, 464050, 464100

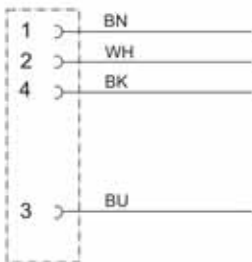

# Actuator sensor interface - M12 - cables

Female M12 angled with PUR cable, open end self-locking screwed connection c-track compatible, halogen free



Description	Part-No.	Type	PU	
<b>5-pole</b>				
Cable length (m)	2.0	443020	KUW5-M12 2M-PUR	1
	5.0	443050	KUW5-M12 5M-PUR	1
	10.0	443100	KUW5-M12 10M-PUR	1
<b>8-pole</b>				
Cable length (m)	2.0	479020	KUW8-M12 2M-PUR	1
	5.0	479050	KUW8-M12 5M-PUR	1
	10.0	479100	KUW8-M12 10M-PUR	1

## Dimensions

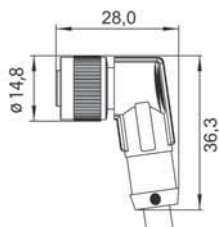

## PIN assignment

443020, 443050, 443100



479020, 479050, 479100



## Circuit diagram

443020, 443050, 443100

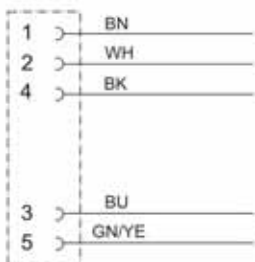

479020, 479050, 479100

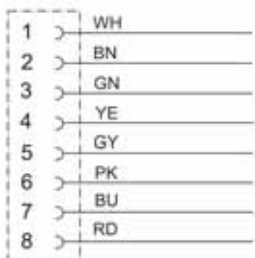

Technical data	5-pole			8-pole		
Nominal voltage	AC/DC 24 V					
Nominal voltage range	max. 60 V			max. 30 V		
Rated current	4 A			2 A		
Pol number	5			8		
Cable length (m)	2.0	5.0	10.0	2.0	5.0	10.0
Status Indication	-					
Current Consumption per LED	-					
Coding	A					
Shielding	-					
<b>General</b>						
Form	M12 × 1, female angled					
Rated insulation voltage (EN 50178)	63 V			36 V		
Test voltage	1.5 kV					
Pollution degree	3					
Insulation resistance	>10 <sup>9</sup> Ω					
Contact resistance	<5 mΩ					
Class of flammability according to UL 94	V0					
Protection class	IP65/IP67/IP68					
Housing material	TPU black					
Contact material	CuSn, gold plated nickel					
Thread material	Zinc die-casting, nickel-plated					
Gasket	NBR					
Cable construction	5 × 0.34 mm <sup>2</sup> (42 × 0.1)			8 × 0.25 mm <sup>2</sup> (32 × 0.1)		
Cable jacket	PUR black					
Conductor insulation	PP					
Cable diameter	5.0 mm			5.9 mm		
Bending radius	10 × cable diameter					
Storage temperature range	-30 °C – 90 °C					
Temperature range connector	-25 °C – 90 °C					
Temperature range cable fixed	-40 °C – 80 °C					
Temperature range cable moving	-25 °C – 80 °C					
Mechanical service life	-					
Weight (kg/piece)	0.100	0.250	0.480	0.110	0.260	0.525
Approvals	cULus					
<b>Accessories</b>						
	Article number		Type		PU	
Cable markers 4×23mm	499988		LB M8/M12		5	
Torque setting tool M12	490091		DM-SET M12		1	

# Actuator sensor interface - M12 - cables

Female M12 angled with PUR cable, shielded 360°, open end self-locking screwed connection  
c-track compatible, halogen free



Description	Part-No.	Type	PU
<b>4-pole</b>			
Cable length (m)	2.0	KUW4-M12 (C) 2M-PUR	1
	5.0	KUW4-M12 (C) 5M-PUR	1
	10.0	KUW4-M12 (C) 10M-PUR	1

Technical data		4-pole	
Nominal voltage		AC/DC 24 V	
Nominal voltage range		max. 250 V	
Rated current		4 A	
Pol number		4	
Cable length (m)	2.0	5.0	10.0
Status Indication		-	
Current Consumption per LED		-	
Coding		A	
Shielding		360°	

General			
Form	M12 × 1, female angled		
Rated insulation voltage (EN 50178)	250 V		
Test voltage	2.5 kV		
Pollution degree	3		
Insulation resistance	>10 <sup>9</sup> Ω		
Contact resistance	<5 mΩ		
Class of flammability according to UL 94	V0		
Protection class	IP65/IP67		
Housing material	TPU black		
Contact material	CuSn, gold plated nickel		
Thread material	Zinc die-casting, nickel-plated		
Gasket	NBR		
Cable construction	4 × 0.34 mm <sup>2</sup> (42 × 0.1)		
Cable jacket	PUR black		
Conductor insulation	PP		
Cable diameter	5.9 mm		
Bending radius	10 × cable diameter		
Storage temperature range	-30 °C – 90 °C		
Temperature range connector	-25 °C – 90 °C		
Temperature range cable fixed	-40 °C – 80 °C		
Temperature range cable moving	-25 °C – 80 °C		
Mechanical service life	-		
Weight (kg/piece)	0.125	0.275	0.520
Approvals	cULus		

Accessories	Article number	Type	PU
Cable markers 4×23mm	499988	LB M8/M12	5
Torque setting tool M12	490091	DM-SET M12	1

### Action chart

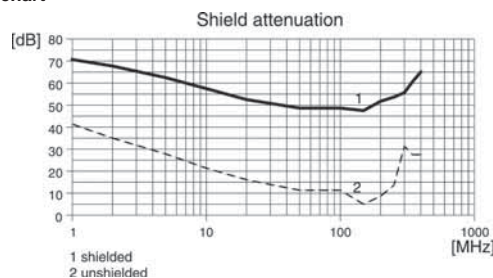

### Dimensions

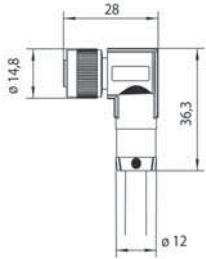

### PIN assignment



### Circuit diagram

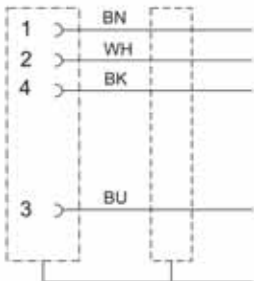



# Actuator sensor interface - M12 - cables

Female M12 angled with PUR cable, shielded 360°, open end self-locking screwed connection  
c-track compatible, halogen free



### Dimensions

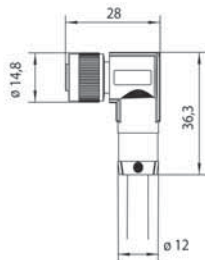

### PIN assignment

456802, 456805, 456810



458902, 458905, 458910



### Circuit diagram

456802, 456805, 456810

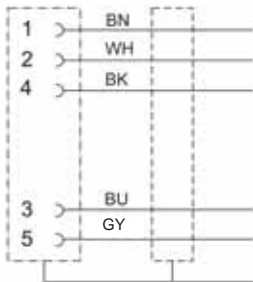

458902, 458905, 458910

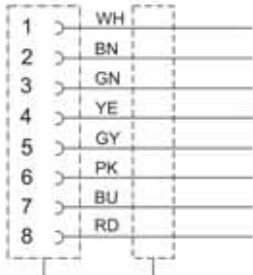

Description	Part-No.	Type	PU
<b>5-pole</b>			
Cable length (m)	2.0	KUW5-M12 (C) 2M-PUR	1
	5.0	KUW5-M12 (C) 5M-PUR	1
	10.0	KUW5-M12 (C) 10M-PUR	1
<b>8-pole</b>			
Cable length (m)	2.0	KUW8-M12 (C) 2M-PUR	1
	5.0	KUW8-M12 (C) 5M-PUR	1
	10.0	KUW8-M12 (C) 10M-PUR	1

Technical data	5-pole			8-pole		
Nominal voltage	AC/DC 24 V					
Nominal voltage range	max. 60 V			max. 30 V		
Rated current	4 A			2 A		
Pol number	5			8		
Cable length (m)	2.0	5.0	10.0	2.0	5.0	10.0
Status Indication	-					
Current Consumption per LED	-					
Coding	A					
Shielding	360°					

General						
Form	M12 × 1, female angled					
Rated insulation voltage (EN 50178)	63 V			36 V		
Test voltage	1.5 kV					
Pollution degree	3					
Insulation resistance	>10 <sup>9</sup> Ω					
Contact resistance	<5 mΩ					
Class of flammability according to UL 94	V0					
Protection class	IP65/IP67					
Housing material	TPU black					
Contact material	CuSn, gold plated nickel					
Thread material	Zinc die-casting, nickel-plated					
Gasket	NBR					
Cable construction	5 × 0.34 mm <sup>2</sup> (42 × 0.1)			8 × 0.25 mm <sup>2</sup> (32 × 0.1)		
Cable jacket	PUR black					
Conductor insulation	PP					
Cable diameter	5.9 mm					
Bending radius	10 × cable diameter					
Storage temperature range	-30 °C – 90 °C					
Temperature range connector	-25 °C – 90 °C					
Temperature range cable fixed	-40 °C – 80 °C					
Temperature range cable moving	-25 °C – 80 °C					
Mechanical service life	-					
Weight (kg/piece)	0.150	0.300	0.565	0.155	0.305	0.570
Approvals	cULus					

Accessories	Article number	Type	PU
Cable markers 4×23mm	499988	LB M8/M12	5
Torque setting tool M12	490091	DM-SET M12	1

### Action chart

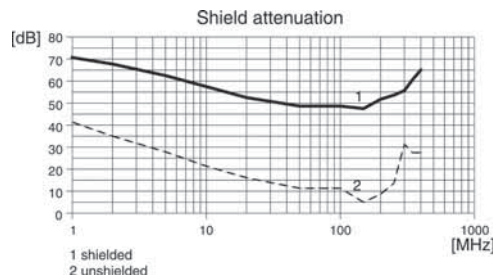

# Actuator sensor interface - M12 - cables

Female M12 angled, with LEDs and PUR cable, open end self-locking screwed connection  
c-track compatible, halogen free



Description	Part-No.	Type	PU	
<b>3-pole</b>				
Cable length (m)	2.0	468020	KUW/LED A-M12 2M-PUR	1
	5.0	468050	KUW/LED A-M12 5M-PUR	1
	10.0	468100	KUW/LED A-M12 10M-PUR	1
<b>4-pole</b>				
Cable length (m)	2.0	469020	KUW/LED P-M12 2M-PUR	1
	5.0	469050	KUW/LED P-M12 5M-PUR	1
	10.0	469100	KUW/LED P-M12 10M-PUR	1

Technical data	3-pole	4-pole			
Nominal voltage		AC/DC 24 V			
Nominal voltage range		DC 10 - 28 V			
Rated current		4 A			
Pol number	3	4			
Cable length (m)	10.0	5.0	2.0	5.0	10.0
Status Indication	Operating voltage: LED green, I/O: LED yellow				
Current Consumption per LED	<10 mA / LED				
Coding	A				
Shielding	-				

General						
Form	M12 × 1, female angled, with LEDs					
Rated insulation voltage (EN 50178)	32 V					
Test voltage	-					
Pollution degree	3					
Insulation resistance	>10 <sup>9</sup> Ω					
Contact resistance	<5 mΩ					
Class of flammability according to UL 94	V0					
Protection class	IP65/IP67/IP68					
Housing material	TPU transparent					
Contact material	CuSn, gold plated nickel					
Thread material	Zinc die-casting, nickel-plated					
Gasket	NBR					
Cable construction	3 × 0.34 mm <sup>2</sup> (42 × 0.1)		4 × 0.34 mm <sup>2</sup> (42 × 0.1)			
Cable jacket	PUR black					
Conductor insulation	PP					
Cable diameter	4.4 mm		4.7 mm			
Bending radius	10 × cable diameter					
Storage temperature range	-30 °C – 90 °C					
Temperature range connector	-25 °C – 90 °C					
Temperature range cable fixed	-40 °C – 80 °C					
Temperature range cable moving	-25 °C – 80 °C					
Mechanical service life	-					
Weight (kg/piece)	0.370	0.190	0.095	0.100	0.200	0.390
Approvals	cULus					

Accessories	Article number	Type	PU
Cable markers 4×23mm	499988	LB M8/M12	5
Torque setting tool M12	490091	DM-SET M12	1

## Dimensions

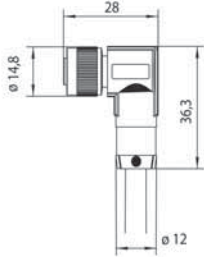

## PIN assignment

468100, 468050, 468020



469020, 469050, 469100



## Circuit diagram

468100, 468050, 468020

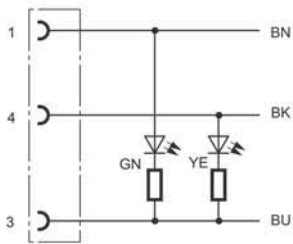

469020, 469050, 469100

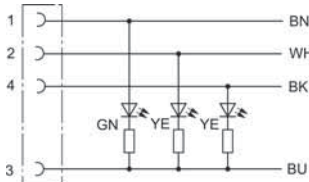

# Actuator sensor interface - M12 / M8 – cables

Male M12 straight to female M8 straight with PUR cable  
self-locking screwed connection  
c-track compatible, halogen free



### Dimensions

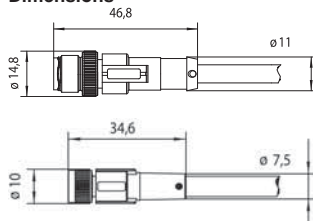

### PIN assignment

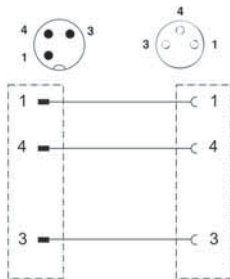

Description	Part-No.	Type	PU	
<b>3-pole</b>				
Cable length (m)	0.3	422003	STG3-M12/KUG3-M8 0,3M-PUR	1
	0.6	422006	STG3-M12/KUG3-M8 0,6M-PUR	1
	1.0	422010	STG3-M12/KUG3-M8 1,0M-PUR	1
	1.5	422015	STG3-M12/KUG3-M8 1,5M-PUR	1
	2.0	422020	STG3-M12/KUG3-M8 2,0M-PUR	1
	5.0	422050	STG3-M12/KUG3-M8 5,0M-PUR	1

Technical data		3-pole					
Nominal voltage		AC/DC 24 V					
Nominal voltage range		max. 60 V					
Rated current		4 A					
Pol number		3					
Cable length (m)	0.3	0.6	1.0	1.5	2.0	5.0	
Status Indication	-						
Current Consumption per LED	-						
Coding	A (M12)						
Shielding	-						

General	
Form	M12 × 1, male straight / M8 × 1, female straight
Rated insulation voltage (EN 50178)	100 V
Test voltage	1.5 kV
Pollution degree	3
Insulation resistance	>10 <sup>9</sup> Ω
Contact resistance	<5 mΩ
Class of flammability according to UL 94	V0
Protection class	IP65/IP67/IP68
Housing material	TPU black
Contact material	CuSn, gold plated nickel
Thread material	Zinc die-casting, nickel-plated
Gasket	NBR
Cable construction	3 × 0.25 mm <sup>2</sup> (32 × 0.1)
Cable jacket	PUR black
Conductor insulation	PP
Cable diameter	4.4 mm
Bending radius	10 × cable diameter
Storage temperature range	-30 °C – 90 °C
Temperature range connector	-25 °C – 90 °C
Temperature range cable fixed	-40 °C – 80 °C
Temperature range cable moving	-25 °C – 80 °C
Mechanical service life	-
Weight (kg/piece)	0.02    0.03    0.04    0.05    0.06    0.16

Approvals		cULus		
Accessories	Article number	Type	PU	
Cable markers 4×23mm	499988	LB M8/M12	5	
Torque setting tool M8	490090	DM-SET M8	1	
Torque setting tool M12	490091	DM-SET M12	1	

# Actuator sensor interface - M12 / M12 – cables

Male M12 straight to female M12, straight with PUR cable  
self-locking screwed connection  
c-track compatible, halogen free



## Dimensions

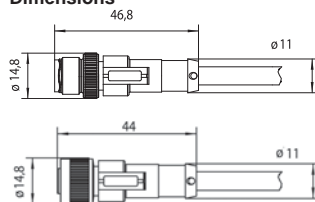

## PIN assignment

428003, 428006, 428010, 428015,  
428020, 428050

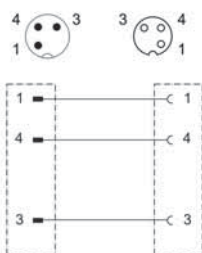

429003, 429006, 429010, 429015,  
429020, 429050

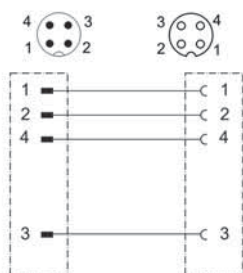

Description	Part-No.	Type	PU	
<b>3-pole</b>				
Cable length (m)	0.3	428003	STG3-M12/KUG3-M12 0,3M-PUR	1
	0.6	428006	STG3-M12/KUG3-M12 0,6M-PUR	1
	1.0	428010	STG3-M12/KUG3-M12 1,0M-PUR	1
	1.5	428015	STG3-M12/KUG3-M12 1,5M-PUR	1
	2.0	428020	STG3-M12/KUG3-M12 2,0M-PUR	1
	5.0	428050	STG3-M12/KUG3-M12 5,0M-PUR	1
<b>4-pole</b>				
Cable length (m)	0.3	429003	STG4-M12/KUG4-M12 0,3M-PUR	1
	0.6	429006	STG4-M12/KUG4-M12 0,6M-PUR	1
	1.0	429010	STG4-M12/KUG4-M12 1,0M-PUR	1
	1.5	429015	STG4-M12/KUG4-M12 1,5M-PUR	1
	2.0	429020	STG4-M12/KUG4-M12 2,0M-PUR	1
	5.0	429050	STG4-M12/KUG4-M12 5,0M-PUR	1

## Technical data

	3-pole						4-pole					
Nominal voltage	AC/DC 24 V											
Nominal voltage range	max. 250 V											
Rated current	4 A											
Pol number	3						4					
Cable length (m)	0.3	0.6	1.0	1.5	2.0	5.0	0.3	0.6	1.0	1.5	2.0	5.0
Status Indication	-											
Current Consumption per LED	-											
Coding	A											
Shielding	-											

## General

Form	M12 × 1, male straight / M12 × 1, female straight												
Rated insulation voltage (EN 50178)	320 V												
Test voltage	2.5 kV												
Pollution degree	3												
Insulation resistance	>10 <sup>9</sup> Ω												
Contact resistance	<5 mΩ												
Class of flammability according to UL 94	V0												
Protection class	IP65/IP67/IP68												
Housing material	TPU black												
Contact material	CuSn, gold plated nickel												
Thread material	Zinc die-casting, nickel-plated												
Gasket	NBR												
Cable construction	3 × 0.34 mm <sup>2</sup> (42 × 0.1)						4 × 0.34 mm <sup>2</sup> (42 × 0.1)						
Cable jacket	PUR black												
Conductor insulation	PP												
Cable diameter	4.4 mm						4.7 mm						
Bending radius	10 × cable diameter												
Storage temperature range	-30 °C – 90 °C												
Temperature range connector	-25 °C – 90 °C												
Temperature range cable fixed	-40 °C – 80 °C												
Temperature range cable moving	-25 °C – 80 °C												
Mechanical service life	-												
Weight (kg/piece)	0.04	0.06	0.08	0.10	0.13	0.24	0.05	0.07	0.09	0.11	0.14	0.26	
Approvals	cULus												
<b>Accessories</b>													
	<b>Article number</b>						<b>Type</b>						<b>PU</b>
Cable markers 4×23mm	499988						LB M8/M12						5
Torque setting tool M12	490091						DM-SET M12						1

# Actuator sensor interface - M12 / M12 – cables

Male M12 straight to female M12 straight with PUR cable  
self-locking screwed connection  
c-track compatible, halogen free



## Dimensions

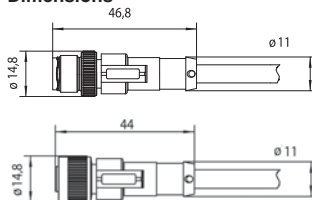

## PIN assignment

442003, 442006, 442010, 442015,  
442020, 442050

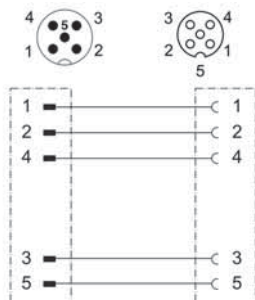

420050, 420003, 420006, 420010,  
420015, 420020

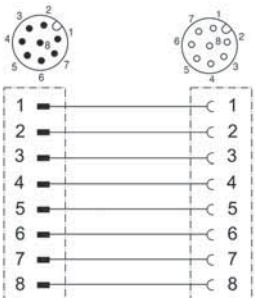

Description	Part-No.	Type	PU								
<b>5-pole</b>											
Cable length (m)	0.3	442003	STG5-M12/KUG5-M12 0,3M-PUR	1							
	0.6	442006	STG5-M12/KUG5-M12 0,6M-PUR	1							
	1.0	442010	STG5-M12/KUG5-M12 1,0M-PUR	1							
	1.5	442015	STG5-M12/KUG5-M12 1,5M-PUR	1							
	2.0	442020	STG5-M12/KUG5-M12 2,0M-PUR	1							
	5.0	442050	STG5-M12/KUG5-M12 5,0M-PUR	1							
<b>8-pole</b>											
Cable length (m)	5.0	420050	STG8-M12/KUG8-M12 5,0M-PUR	1							
	0.3	420003	STG8-M12/KUG8-M12 0,3M-PUR	1							
	0.6	420006	STG8-M12/KUG8-M12 0,6M-PUR	1							
	1.0	420010	STG8-M12/KUG8-M12 1,0M-PUR	1							
	1.5	420015	STG8-M12/KUG8-M12 1,5M-PUR	1							
	2.0	420020	STG8-M12/KUG8-M12 2,0M-PUR	1							
<b>Technical data</b>											
		<b>5-pole</b>	<b>8-pole</b>								
Nominal voltage	AC/DC 24 V										
Nominal voltage range	max. 30 V										
Rated current	4 A		2 A								
Pol number	5		8								
Cable length (m)	0.3	0.6	1.0	1.5	2.0	5.0	0.3	0.6	1.0	1.5	2.0
Status Indication	-										
Current Consumption per LED	-										
Coding	A										
Shielding	-										
<b>General</b>											
Form	M12 × 1, male straight / M12 × 1, female straight										
Rated insulation voltage (EN 50178)	63 V					36 V					
Test voltage	1.5 kV										
Pollution degree	3										
Insulation resistance	>10 <sup>9</sup> Ω										
Contact resistance	<5 mΩ										
Class of flammability according to UL 94	V0										
Protection class	IP65/IP67/IP68										
Housing material	TPU black										
Contact material	CuSn, gold plated nickel										
Thread material	Zinc die-casting, nickel-plated										
Gasket	NBR										
Cable construction	5 × 0.34 mm <sup>2</sup> (42 × 0.1)					8 × 0.25 mm <sup>2</sup> (32 × 0.1)					
Cable jacket	PUR black										
Conductor insulation	PP										
Cable diameter	5.0 mm					5.9 mm					
Bending radius	10 × cable diameter										
Storage temperature range	-30 °C – 90 °C										
Temperature range connector	-25 °C – 90 °C										
Temperature range cable fixed	-40 °C – 80 °C										
Temperature range cable moving	-25 °C – 80 °C										
Mechanical service life	-										
Weight (kg/piece)	0.05	0.06	0.09	0.11	0.14	0.30	0.05	0.06	0.09	0.11	0.14
Approvals	cULus										
<b>Accessories</b>		<b>Article number</b>	<b>Type</b>	<b>PU</b>							
Cable markers 4×23mm		499988	LB M8/M12	5							
Torque setting tool M12		490091	DM-SET M12	1							

# Actuator sensor interface - M12 / M12 – cables

Male M12 straight to female M12 angled with PUR cable  
self-locking screwed connection  
c-track compatible, halogen free



## Dimensions

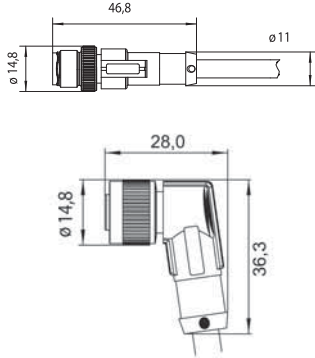

## PIN assignment

467003, 467006, 467010, 467015,  
467020, 467050

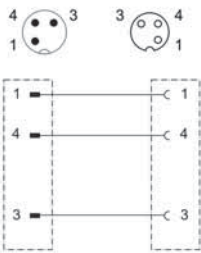

418003, 418006, 418010, 418015,  
418020, 418050

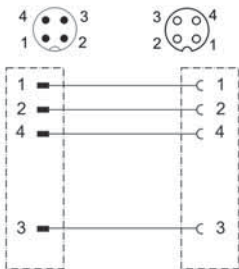

Description	Part-No.	Type	PU	
<b>3-pole</b>				
Cable length (m)	0.3	467003	STG3-M12/KUW3-M12 0,3M-PUR	1
	0.6	467006	STG3-M12/KUW3-M12 0,6M-PUR	1
	1.0	467010	STG3-M12/KUW3-M12 1,0M-PUR	1
	1.5	467015	STG3-M12/KUW3-M12 1,5M-PUR	1
	2.0	467020	STG3-M12/KUW3-M12 2,0M-PUR	1
	5.0	467050	STG3-M12/KUW3-M12 5,0M-PUR	1
<b>4-pole</b>				
Cable length (m)	0.3	418003	STG4-M12/KUW4-M12 0,3M-PUR	1
	0.6	418006	STG4-M12/KUW4-M12 0,6M-PUR	1
	1.0	418010	STG4-M12/KUW4-M12 1,0M-PUR	1
	1.5	418015	STG4-M12/KUW4-M12 1,5M-PUR	1
	2.0	418020	STG4-M12/KUW4-M12 2,0M-PUR	1
	5.0	418050	STG4-M12/KUW4-M12 5,0M-PUR	1

## Technical data

	3-pole						4-pole					
Nominal voltage	AC/DC 24 V											
Nominal voltage range	max. 250 V											
Rated current	4 A											
Pol number	3						4					
Cable length (m)	0.3	0.6	1.0	1.5	2.0	5.0	0.3	0.6	1.0	1.5	2.0	5.0
Status Indication	-											
Current Consumption per LED	-											
Coding	A											
Shielding	-											

## General

Form	M12 × 1, male straight / M12 × 1, female angled											
Rated insulation voltage (EN 50178)	320 V											
Test voltage	2.5 kV											
Pollution degree	3											
Insulation resistance	>10 <sup>9</sup> Ω											
Contact resistance	<5 mΩ											
Class of flammability according to UL 94	V0											
Protection class	IP65/IP67/IP68											
Housing material	TPU black											
Contact material	CuSn, gold plated nickel											
Thread material	Zinc die-casting, nickel-plated											
Gasket	NBR											
Cable construction	3 × 0.34 mm <sup>2</sup> (42 × 0.1)						4 × 0.34 mm <sup>2</sup> (42 × 0.1)					
Cable jacket	PUR black											
Conductor insulation	PP											
Cable diameter	4.4 mm						4.7 mm					
Bending radius	10 × cable diameter											
Storage temperature range	-30 °C – 90 °C											
Temperature range connector	-25 °C – 90 °C											
Temperature range cable fixed	-40 °C – 80 °C											
Temperature range cable moving	-25 °C – 80 °C											
Mechanical service life	-											
Weight (kg/piece)	0.03	0.04	0.06	0.08	0.10	0.22	0.05	0.06	0.08	0.10	0.13	0.24
Approvals	cULus											

## Accessories

	Article number	Type	PU
Cable markers 4×23mm	499988	LB M8/M12	5
Torque setting tool M12	490091	DM-SET M12	1

# Actuator sensor interface - M12 / M12 – cables

Male M12 straight to female M12 angled with PUR cable  
self-locking screwed connection  
c-track compatible, halogen free



### Dimensions

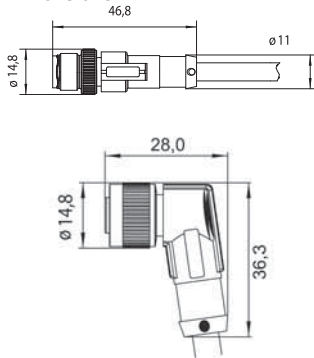

### PIN assignment

440003, 440006, 440015, 440010,  
440020, 440050

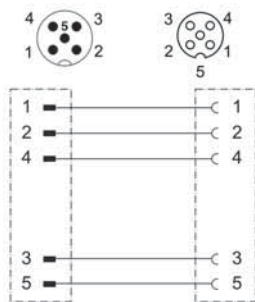

424003, 424006, 424010, 424015,  
424020, 424050

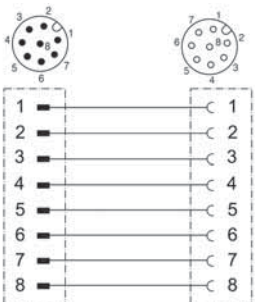

Description	Part-No.	Type	PU	
<b>5-pole</b>				
Cable length (m)	0.3	440003	STG5-M12/KUW5-M12 0,3M-PUR	1
	0.6	440006	STG5-M12/KUW5-M12 0,6M-PUR	1
	1.5	440015	STG5-M12/KUW5-M12 1,5M-PUR	1
	1.0	440010	STG5-M12/KUW5-M12 1,0M-PUR	1
	2.0	440020	STG5-M12/KUW5-M12 2,0M-PUR	1
	5.0	440050	STG5-M12/KUW5-M12 5,0M-PUR	1
<b>8-pole</b>				
Cable length (m)	0.3	424003	STG8-M12/KUW8-M12 0,3M-PUR	1
	0.6	424006	STG8-M12/KUW8-M12 0,6M-PUR	1
	1.0	424010	STG8-M12/KUW8-M12 1,0M-PUR	1
	1.5	424015	STG8-M12/KUW8-M12 1,5M-PUR	1
	2.0	424020	STG8-M12/KUW8-M12 2,0M-PUR	1
	5.0	424050	STG8-M12/KUW8-M12 5,0M-PUR	1

Technical data	5-pole					8-pole						
Nominal voltage	AC/DC 24 V											
Nominal voltage range	max. 30 V											
Rated current	4 A					2 A						
Pol number	5					8						
Cable length (m)	0.3	0.6	1.5	1.0	2.0	5.0	0.3	0.6	1.0	1.5	2.0	5.0
Status Indication	-											
Current Consumption per LED	-											
Coding	A											
Shielding	-											

General												
Form	M12 × 1, male straight / M12 × 1, female straight											
Rated insulation voltage (EN 50178)	63 V					36 V						
Test voltage	1.5 kV											
Pollution degree	3											
Insulation resistance	>10 <sup>9</sup> Ω											
Contact resistance	<5 mΩ											
Class of flammability according to UL 94	V0											
Protection class	IP65/IP67/IP68											
Housing material	TPU black											
Contact material	CuSn, gold plated nickel											
Thread material	Zinc die-casting, nickel-plated											
Gasket	NBR											
Cable construction	5 × 0.34 mm <sup>2</sup> (42 × 0.1)					8 × 0.25 mm <sup>2</sup> (32 × 0.1)						
Cable jacket	PUR black											
Conductor insulation	PP											
Cable diameter	5.0 mm					5.9 mm						
Bending radius	10 × cable diameter											
Storage temperature range	-30 °C – 90 °C											
Temperature range connector	-25 °C – 90 °C											
Temperature range cable fixed	-40 °C – 80 °C											
Temperature range cable moving	-25 °C – 80 °C											
Mechanical service life	-											
Weight (kg/piece)	0.05	0.06	0.13	0.08	0.11	0.22	0.05	0.06	0.08	0.11	0.13	0.22
Approvals	cULus											

Accessories	Article number	Type	PU
Cable markers 4×23mm	499988	LB M8/M12	5
Torque setting tool M12	490091	DM-SET M12	1

# Actuator sensor interface - M12 / M12 – cables

Male M12 straight to female M12 angled with PUR cable and 360° shielding  
self-locking screwed connection  
c-track compatible, halogen free



## Dimensions

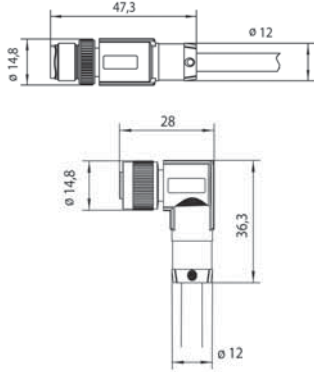

## PIN assignment

457503, 457506, 457510, 457515,  
457520, 457550

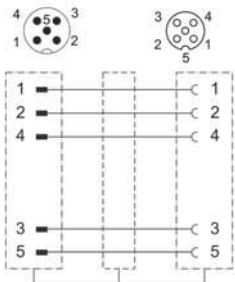

459203, 459206, 459210, 459215,  
459220, 459250

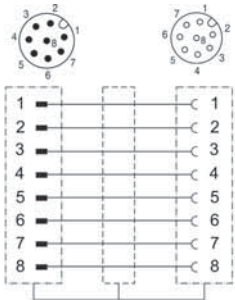

Description	Part-No.	Type	PU
<b>5-pole</b>			
Cable length (m)	0.3	457503	STG5-M12/KUW5-M12 (C) 0,3M-PUR 1
	0.6	457506	STG5-M12/KUW5-M12 (C) 0,6M-PUR 1
	1.0	457510	STG5-M12/KUW5-M12 (C) 1,0M-PUR 1
	1.5	457515	STG5-M12/KUW5-M12 (C) 1,5M-PUR 1
	2.0	457520	STG5-M12/KUW5-M12 (C) 2,0M-PUR 1
	5.0	457550	STG5-M12/KUW5-M12 (C) 5,0M-PUR 1
<b>8-pole</b>			
Cable length (m)	0.3	459203	STG8-M12/KUW8-M12 (C) 0,3M-PUR 1
	0.6	459206	STG8-M12/KUW8-M12 (C) 0,6M-PUR 1
	1.0	459210	STG8-M12/KUW8-M12 (C) 1,0M-PUR 1
	1.5	459215	STG8-M12/KUW8-M12 (C) 1,5M-PUR 1
	2.0	459220	STG8-M12/KUW8-M12 (C) 2,0M-PUR 1
	5.0	459250	STG8-M12/KUW8-M12 (C) 5,0M-PUR 1

## Technical data

	5-pole					8-pole						
Nominal voltage	AC/DC 24 V											
Nominal voltage range	max. 30 V											
Rated current	4 A					2 A						
Pol number	5					8						
Cable length (m)	0.3	0.6	1.0	1.5	2.0	5.0	0.3	0.6	1.0	1.5	2.0	5.0
Status Indication	-											
Current Consumption per LED	-											
Coding	A											
Shielding	360°											
<b>General</b>												
Form	M12 × 1, male straight / M12 × 1, female straight											
Rated insulation voltage (EN 50178)	63 V					36 V						
Test voltage	1.5 kV											
Pollution degree	3											
Insulation resistance	>10 <sup>9</sup> Ω											
Contact resistance	<5 mΩ											
Class of flammability according to UL 94	V0											
Protection class	IP65/IP67											
Housing material	TPU black											
Contact material	CuSn, gold plated nickel											
Thread material	Zinc die-casting, nickel-plated											
Gasket	NBR											
Cable construction	5 × 0.34 mm <sup>2</sup> (42 × 0.1)					8 × 0.25 mm <sup>2</sup> (32 × 0.1)						
Cable jacket	PUR black											
Conductor insulation	PP											
Cable diameter	5.9 mm											
Bending radius	10 × cable diameter											
Storage temperature range	-30 °C – 90 °C											
Temperature range connector	-25 °C – 90 °C											
Temperature range cable fixed	-40 °C – 80 °C											
Temperature range cable moving	-25 °C – 80 °C											
Mechanical service life	-											
Weight (kg/piece)	0.06	0.08	0.11	0.13	0.17	0.33	0.05	0.06	0.08	0.11	0.13	0.22
Approvals	cULus											

Accessories	Article number	Type	PU
Cable markers 4×23mm	499988	LB M8/M12	5
Torque setting tool M12	490091	DM-SET M12	1

## Action chart

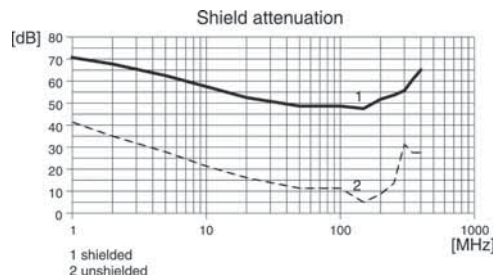



# Actuator sensor interface - M12 / M12 – cables

Male M12 straight to female M12 angled with LEDs and PUR cable  
self-locking screwed connection  
c-track compatible, halogen free



## Dimensions

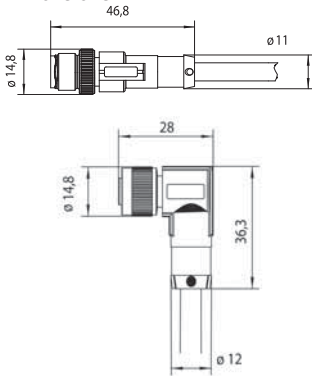

## PIN assignment

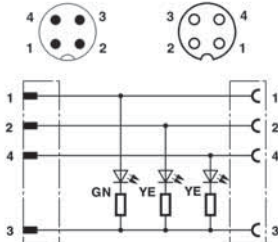

Description	Part-No.	Type	PU
<b>4-pole</b>			
Cable length (m)	0.3	431003	STG4-M12/KUW4-M12 LED P 0,3M-PUR
	0.6	431006	STG4-M12/KUW4-M12 LED P 0,6M-PUR
	1.0	431010	STG4-M12/KUW4-M12 LED P 1,0M-PUR
	1.5	431015	STG4-M12/KUW4-M12 LED P 1,5M-PUR
	2.0	431020	STG4-M12/KUW4-M12 LED P 2,0M-PUR
	5.0	431050	STG4-M12/KUW4-M12 LED P 5,0M-PUR

Technical data		4-pole					
Nominal voltage		DC 24 V					
Nominal voltage range		DC 10 - 28 V					
Rated current		4 A					
Pol number		4					
Cable length (m)	0.3	0.6	1.0	1.5	2.0	5.0	
Status Indication		Operating voltage: LED green, I/O: LED yellow					
Current Consumption per LED		<10 mA					
Coding		A					
Shielding		-					
<b>General</b>							
Form		M12 × 1, male straight / M12 × 1, female angled with LEDs					
Rated insulation voltage (EN 50178)		32 V					
Test voltage		-					
Pollution degree		3					
Insulation resistance		>10 <sup>9</sup> Ω					
Contact resistance		<5 mΩ					
Class of flammability according to UL 94		V0					
Protection class		IP65/IP67/IP68					
Housing material		TPU black / transparent					
Contact material		CuSn, gold plated nickel					
Thread material		Zinc die-casting, nickel-plated					
Gasket		NBR					
Cable construction		4 × 0.34 mm <sup>2</sup> (42 × 0.1)					
Cable jacket		PUR black					
Conductor insulation		PP					
Cable diameter		4.7 mm					
Bending radius		10 × cable diameter					
Storage temperature range		-30 °C – 90 °C					
Temperature range connector		-25 °C – 90 °C					
Temperature range cable fixed		-40 °C – 80 °C					
Temperature range cable moving		-25 °C – 80 °C					
Mechanical service life		-					
Weight (kg/piece)	0.05	0.06	0.08	0.10	0.13	0.24	
Approvals		cULus					
<b>Accessories</b>		<b>Article number</b>	<b>Type</b>			<b>PU</b>	
Cable markers 4×23mm		499988	LB M8/M12			5	
Torque setting tool M12		490091	DM-SET M12			1	

# Actuator sensor interface - M12 / valve suppressor

Male M12 straight to valve connector form A  
with protection device and LED status indication  
c-track compatible, halogen free



## Dimensions

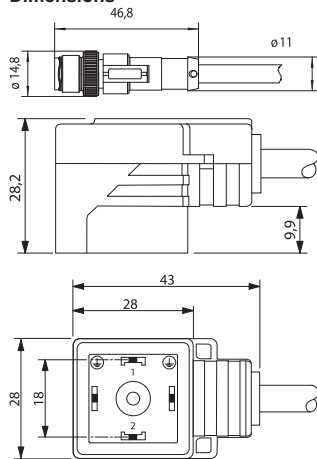

## PIN assignment

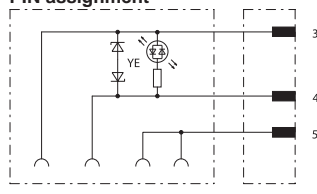

## Pin layout

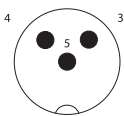

Description	Part-No.	Type	PU	
<b>Construction A + Z-diode</b>				
Cable length (m)	0.3	435003	STG3 M12/LZ-A 0,3m PUR	1
	0.6	435006	STG3 M12/LZ-A 0,6m PUR	1
	1.0	435010	STG3 M12/LZ-A 1,0m PUR	1
	1.5	435015	STG3 M12/LZ-A 1,5m PUR	1
	2.0	435020	STG3 M12/LZ-A 2,0m PUR	1
	5.0	435050	STG3 M12/LZ-A 5,0m PUR	1

Technical data		Construction A + Z-diode				
Nominal voltage		AC/DC 24 V				
Nominal voltage range		10 – 28 V				
Rated current		4 A				
Rated frequency		50–60 Hz				
Protection device		Z-diode + LED				
Pol number		3				
Cable length (m)	0.3	0.6	1.0	1.5	2.0	5.0
Status Indication		LED yellow				
Current Consumption per LED		<10 mA / LED				
Shut-off points		≥ 52V				
Holding capacitance		≤ 100VA				

General		M12×1, male straight / form A, contact clearance 18 mm				
Form		M12×1, male straight / form A, contact clearance 18 mm				
Rated insulation voltage (EN 50178)		32 V				
Test voltage		–				
Pollution degree		3				
Insulation resistance		≥100 MΩ				
Contact resistance		<5 mΩ				
Class of flammability according to UL 94		V0				
Protection class		IP65/IP67				
Housing material		TPU black / transparent				
Contact material		CuSn, gold plated nickel				
Thread material		Zinc die-casting, nickel-plated				
Gasket		–				
Cable construction		3 × 0.5 mm <sup>2</sup>				
Cable jacket		PUR black				
Conductor insulation		PP				
Cable diameter		4.5 mm				
Bending radius		10 × cable diameter				
Storage temperature range		-30 °C – 90 °C				
Temperature range connector		-20 °C – 85 °C				
Temperature range cable fixed		-40 °C – 80 °C				
Temperature range cable moving		-20 °C – 80 °C				
Mechanical service life		–				
Weight (kg/piece)	0.045	0.053	0.065	0.079	0.096	0.146
Standards		EN 175301-803				
Approvals		–				

Accessories	Article number	Type	PU
Cable markers 4×23mm	499988	LB M8/M12	5
Torque setting tool M12	490091	DM-SET M12	1

## Comments

Silicone free, Free from paint wetting impairment substances, resistant to microbes and hydrolysis. Very good resistance to acids, alkalines and solvents. The material resistance is based on the application for use with aggressive media.

# Actuator sensor interface - M12 / valve suppressor

Male M12 straight to valve connector form A for pressure switch  
with LED status indication  
c-track compatible, halogen free



## Dimensions

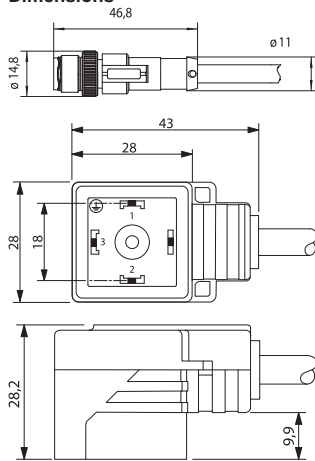

## PIN assignment

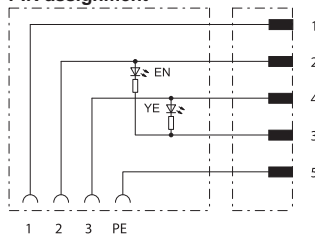

## Pin layout



Description	Part-No.	Type	PU	
<b>Construction A for Pressure switch</b>				
Cable length (m)	0.3	445003	STG5 M12/LDS-A 0° 0,3m PUR	1
	0.6	445006	STG5 M12/LDS-A 0° 0,6m PUR	1
	1.0	445010	STG5 M12/LDS-A 0° 1,0m PUR	1
	1.5	445015	STG5 M12/LDS-A 0° 1,5m PUR	1
	2.0	445020	STG5 M12/LDS-A 0° 2,0m PUR	1
	5.0	445050	STG5 M12/LDS-A 0° 5,0m PUR	1

Technical data		Construction A for Pressure switch					
Nominal voltage		DC 24 V					
Nominal voltage range		DC 10 - 28 V					
Rated current		4 A					
Rated frequency		-					
Protection device		-					
Pol number		5					
Cable length (m)	0.3	0.6	1.0	1.5	2.0	5.0	
Status Indication	LED yellow/green						
Current Consumption per LED	<10 mA / LED						
Shut-off points	-						
Holding capacitance	-						

General						
Form	M12×1, male straight / Form A, contact clearance 18 mm, 0°					
Rated insulation voltage (EN 50178)	32 V					
Test voltage	-					
Pollution degree	3					
Insulation resistance	≥100 MΩ					
Contact resistance	<5 mΩ					
Class of flammability according to UL 94	V0					
Protection class	IP65/IP67					
Housing material	TPU black / transparent					
Contact material	CuSn, gold plated nickel					
Thread material	Zinc die-casting, nickel-plated					
Gasket	-					
Cable construction	5 × 0.5 mm <sup>2</sup>					
Cable jacket	PUR black					
Conductor insulation	PP					
Cable diameter	5.3 mm					
Bending radius	10 × cable diameter					
Storage temperature range	-30 °C – 90 °C					
Temperature range connector	-25 °C – 90 °C					
Temperature range cable fixed	-40 °C – 80 °C					
Temperature range cable moving	-20 °C – 70 °C					
Mechanical service life	-					
Weight (kg/piece)	0.064	0.078	0.096	0.119	0.142	0.280
Standards	EN 175301-803					
Approvals	-					

Accessories	Article number	Type	PU
Cable markers 4×23mm	499988	LB M8/M12	5
Torque setting tool M12	490091	DM-SET M12	1

**Comments**  
Silicone free, Free from paint wetting impairment substances, resistant to microbes and hydrolysis Very good resistance to acids, alkalines and solvents. The material resistance is based on the application for use with aggressive media.

# Actuator sensor interface - M12 / valve suppressor

Male M12 straight to valve suppressor form B / form BI  
with protection device and LED status indication  
c-track compatible, halogen free



## Dimensions

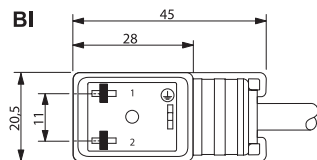
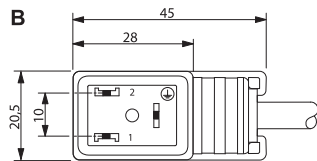
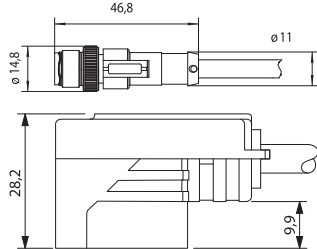

## PIN assignment

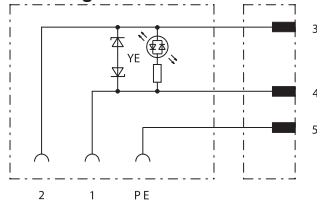

## Pin layout

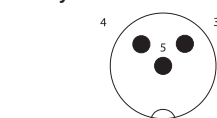

Description	Part-No.	Type	PU	
<b>Construction B + Z-diode</b>				
Cable length (m)	0.3	436003	STG3 M12/LZ-B 0° 0,3m PUR	1
	0.6	436006	STG3 M12/LZ-B 0° 0,6m PUR	1
	1.0	436010	STG3 M12/LZ-B 0° 1,0m PUR	1
	1.5	436015	STG3 M12/LZ-B 0° 1,5m PUR	1
	2.0	436020	STG3 M12/LZ-B 0° 2,0m PUR	1
	5.0	436050	STG3 M12/LZ-B 0° 5,0m PUR	1
<b>Construction BI + Z diode</b>				
Cable length (m)	0.3	439003	STG3 M12/LZ-BI 0° 0,3m PUR	1
	0.6	439006	STG3 M12/LZ-BI 0° 0,6m PUR	1
	1.0	439010	STG3 M12/LZ-BI 0° 1,0m PUR	1
	1.5	439015	STG3 M12/LZ-BI 0° 1,5m PUR	1
	2.0	439020	STG3 M12/LZ-BI 0° 2,0m PUR	1
	5.0	439050	STG3 M12/LZ-BI 0° 5,0m PUR	1

Technical data	Construction B + Z-diode					Construction BI + Z diode						
Nominal voltage	AC/DC 24 V											
Nominal voltage range	10 – 28 V											
Rated current	4 A											
Rated frequency	50–60 Hz											
Protection device	Z-diode + LED											
Pol number	3											
Cable length (m)	0.3	0.6	1.0	1.5	2.0	5.0	0.3	0.6	1.0	1.5	2.0	5.0
Status Indication	LED yellow											
Current Consumption per LED	4mA / LED											
Shut-off points	≥ 52V											
Holding capacitance	≤ 100VA											

General	M12×1, male straight / Form B					M12×1, male straight / Form BI						
Form	M12×1, male straight / Form B					M12×1, male straight / Form BI						
Rated insulation voltage (EN 50178)	32 V											
Test voltage	–											
Pollution degree	3											
Insulation resistance	≥100 MΩ											
Contact resistance	<5 mΩ											
Class of flammability according to UL 94	V0											
Protection class	IP65/IP67											
Housing material	TPU black / transparent											
Contact material	CuSn, gold plated nickel											
Thread material	Zinc die-casting, nickel-plated											
Gasket	–											
Cable construction	3 × 0.5 mm <sup>2</sup>											
Cable jacket	PUR black											
Conductor insulation	PP											
Cable diameter	4.5 mm											
Bending radius	10 × cable diameter											
Storage temperature range	-30 °C – 90 °C											
Temperature range connector	-25 °C – 90 °C											
Temperature range cable fixed	-40 °C – 80 °C											
Temperature range cable moving	-20 °C – 70 °C											
Mechanical service life	–											
Weight (kg/piece)	0.06	0.07	0.09	0.11	0.14	0.28	0.06	0.07	0.09	0.11	0.14	0.28
	4	8	6	9	2	0	4	8	6	9	2	0

Standards	EN 175301-803											
Approvals	–											
<b>Accessories</b>	<b>Article number</b>	<b>Type</b>	<b>PU</b>									
Cable markers 4×23mm	499988	LB M8/M12	5									
Torque setting tool M12	490091	DM-SET M12	1									

**Comments**  
Silicone free, Free from paint wetting impairment substances, resistant to microbes and hydrolysis. Very good resistance to acids, alkalines and solvents. The material resistance is based on the application for use with aggressive media.

# Actuator sensor interface - M12 / valve suppressor

Male M12 straight to valve suppressor form C / form CI  
with protection device and LED status indication  
c-track compatible, halogen free



## Dimensions

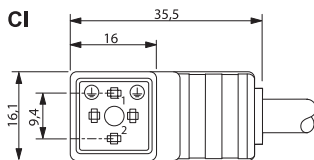
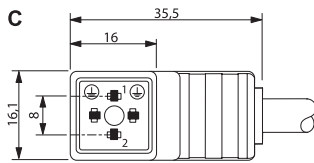
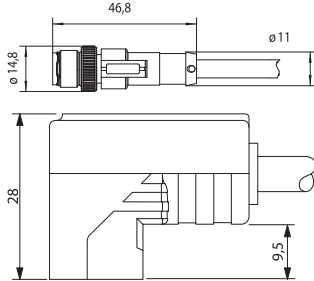

## PIN assignment

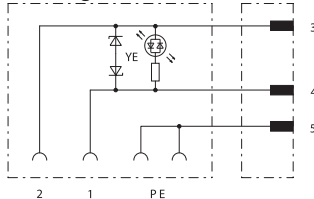

## Pin layout

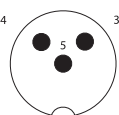

Description	Part-No.	Type	PU	
<b>Construction C + Z-diode</b>				
Cable length (m)	0.3	438003	STG3 M12/LZ-C 0,3m PUR	1
	0.6	438006	STG3 M12/LZ-C 0,6m PUR	1
	1.0	438010	STG3 M12/LZ-C 1,0m PUR	1
	1.5	438015	STG3 M12/LZ-C 1,5m PUR	1
	2.0	438020	STG3 M12/LZ-C 2,0m PUR	1
	5.0	438050	STG3 M12/LZ-C 5,0m PUR	1
<b>Construction CI + Z-diode</b>				
Cable length (m)	0.3	441003	STG3 M12/LZ-CI 0,3m PUR	1
	0.6	441006	STG3 M12/LZ-CI 0,6m PUR	1
	1.0	441010	STG3 M12/LZ-CI 1,0m PUR	1
	1.5	441015	STG3 M12/LZ-CI 1,5m PUR	1
	2.0	441020	STG3 M12/LZ-CI 2,0m PUR	1
	5.0	441050	STG3 M12/LV-CI 5,0m PUR	1

Technical data	Construction C + Z-diode					Construction CI + Z-diode						
Nominal voltage	AC/DC 24 V											
Nominal voltage range	10 – 28 V											
Rated current	4 A											
Rated frequency	50–60 Hz											
Protection device	Z-diode + LED											
Pol number	3					3						
Cable length (m)	0.3	0.6	1.0	1.5	2.0	5.0	0.3	0.6	1.0	1.5	2.0	5.0
Status Indication	LED yellow											
Current Consumption per LED	≤10 mA / LED											
Shut-off points	≥ 52V											
Holding capacitance	≤ 100VA											

General	M12×1, male straight / Form C					M12×1, male straight / Form CI						
Form	M12×1, male straight / Form C					M12×1, male straight / Form CI						
Rated insulation voltage (EN 50178)	32 V											
Test voltage	–											
Pollution degree	3											
Insulation resistance	≥100 MΩ											
Contact resistance	> 5mΩ											
Class of flammability according to UL 94	V0											
Protection class	IP65/IP67											
Housing material	TPU black / transparent											
Contact material	CuSn, gold plated nickel											
Thread material	Zinc die-casting, nickel-plated											
Gasket	–											
Cable construction	3 × 0.5 mm <sup>2</sup>											
Cable jacket	PUR black											
Conductor insulation	PP											
Cable diameter	4.5 mm											
Bending radius	10 x cable diameter											
Storage temperature range	-30 °C – 90 °C											
Temperature range connector	-25 °C – 90 °C											
Temperature range cable fixed	-40 °C – 80 °C											
Temperature range cable moving	-20 °C – 70 °C											
Mechanical service life	–											
Weight (kg/piece)	0.06	0.07	0.09	0.11	0.14	0.28	0.06	0.07	0.09	0.11	0.14	0.28
	4	8	6	9	2	0	4	8	6	9	2	0

Standards	EN 175301-803											
Approvals	–											
<b>Accessories</b>	<b>Article number</b>	<b>Type</b>	<b>PU</b>									
Cable markers 4×23mm	499988	LB M8/M12	200									
Torque setting tool M12	490091	DM-SET M12	1									
Cable markers 4×11mm	681313	BZT 0411	100									

## Comments

Silicone free, Free from paint wetting impairment substances, resistant to microbes and hydrolysis. Very good resistance to acids, alkalines and solvents. The material resistance is based on the application for use with aggressive media.

# Actuator sensor interface - M8 - connector

field wireable connector, M8 straight  
Male / female  
Screw terminal



## Dimensions

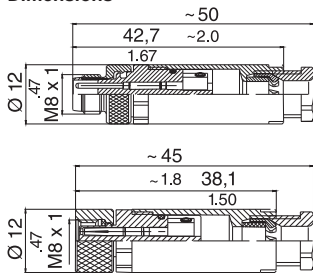

## Pin layout

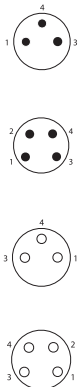

Description	Part-No.	Type	PU	
<b>Male</b>				
Pol number	3	490035	STGK-M8 3POL SK	1
	4	490057	STGK-M8 4POL SK	1
<b>Female</b>				
Pol number	3	490037	KUGK-M8 3POL SK	1
	4	490059	KUGK-M8 4POL SK	1

Technical data		Male	Female	
Nominal voltage		AC/DC 24 V		
Nominal voltage range		max. 60 V		
Rated current		4 A		
Pol number	3	4	3	4
Cable length (m)		-		
Status Indication		-		
Current Consumption per LED		-		
Coding		-		
Shielding		-		
<b>General</b>				
Termination		Screw terminal 0.14 – 0.5 mm <sup>2</sup>		
Form		M8 × 1, male	M8 × 1, female	
Contact material		CuZn, gold-plated		
Gasket		-	NBR	
Test voltage		1.5 kV		
Pollution degree		3		
Insulation resistance		>10 <sup>10</sup> Ω		
Contact resistance		<3 mΩ		
Class of flammability according to UL 94		V0		
Protection class		IP 67, in screwed condition		
Housing material		PBT black		
Thread material		CuSn nickel plated		
Cable construction		-		
Cable jacket		-		
Conductor insulation		-		
Cable diameter		3.5 – 5 mm		
Bending radius		-		
Storage temperature range		-40 °C – 90 °C		
Temperature range connector		-25 °C – 85 °C		
Mechanical service life		>100 insertion cycles		
Weight (kg/piece)		0.040		
Approvals		-		

Accessories	Article number	Type	Outer jacket
matching cables	117240	3×0.25	PUR
	117241	4×0.25	PUR
	117243	3×0.34	PUR
	117244	4×0.34	PUR

## Mounting diagram

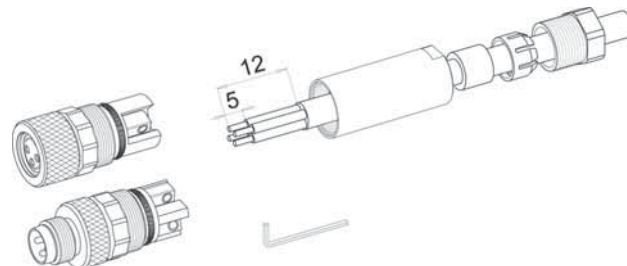

# Actuator sensor interface - M8 - connector

field wireable connector, M8 straight  
Male / female  
IDC quick-connect technology



### Dimensions

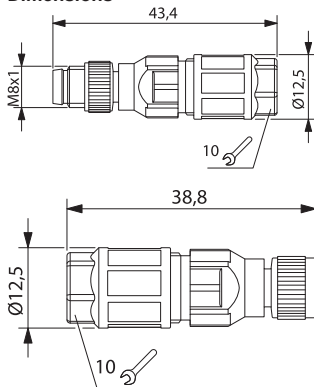

### Pin layout

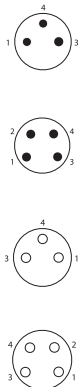

Description	Part-No.	Type	PU	
<b>Male</b>				
Pol number	3	490123	STGK-M8 3POL SNK	1
	4	490124	STGK-M8 4POL SNK	1
<b>Female</b>				
Pol number	3	490125	KUGK-M8 3POL SNK	1
	4	490126	KUGK-M8 4POL SNK	1

Technical data	Male		Female	
Nominal voltage	AC/DC 24 V			
Nominal voltage range	max. 60 V	max. 30 V	max. 60 V	max. 30 V
Rated current	-			
Pol number	3	4	3	4
Cable length (m)	-			
Status Indication	-			
Current Consumption per LED	-			
Coding	-			
Shielding	-			
<b>General</b>				
Termination	IDC 0.25 – 0.5 mm <sup>2</sup> , AWG 22/24, class 2– 6			
Form	M8 × 1, male		M8 × 1, female	
Contact material	CuSn, gold-plated			
Gasket	-		NBR	
Test voltage	1.5 kV	0.8 kV	1.5 kV	0.8 kV
Pollution degree	3			
Insulation resistance	≥100 MΩ			
Contact resistance	≤5 mΩ			
Class of flammability according to UL 94	V0			
Protection class	IP 67, in screwed condition			
Housing material	PA 6 black			
Thread material	CuSn nickel plated			
Cable construction	-			
Cable jacket	-			
Conductor insulation	PVC / PE / PP			
Cable diameter	2.5 – 5 mm			
Bending radius	-			
Storage temperature range	-40 °C – 90 °C			
Temperature range connector	-40 °C – 80 °C			
Mechanical service life	10× connection of cables with the same gauge			
Weight (kg/piece)	0.008		0.007	
Standards	IEC 61076-2-104			
<b>Accessories</b>	<b>Article number</b>	<b>Type</b>	<b>Outer jacket</b>	
matching cables	117240	3×0.25	PUR	
	117241	4×0.25	PUR	
	117243	3×0.34	PUR	
	117244	4×0.34	PUR	

### Mounting diagram

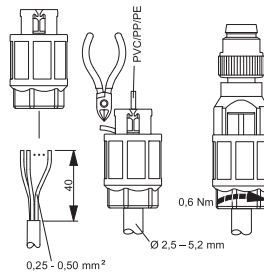

# Actuator sensor interface - M12 - connector

field wireable connector, M12 straight  
Male - A coded  
Screw terminal



## Dimensions

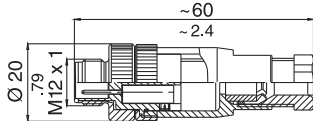

## Pin layout



Description	Part-No.	Type	PU	
<b>Male</b>				
Pol number	4	490017	STGK-M12 4POL SK	1
	5	490018	STGK-M12 5POL SK	1
	8	490070	STGK-M12 8POL SK	1

Technical data		Male	
Nominal voltage		AC/DC 24 V	
Nominal voltage range	250 V	125 V	60 V
Rated current	4 A	2 A	
Pol number	4	5	8
Cable length (m)	-		
Status Indication	-		
Current Consumption per LED	-		
Coding	A		
Shielding	-		

General		M12 × 1, male	
Rated insulation voltage (EN 50178)	2.5 kV	1.5 kV	800 V
Test voltage	2.95 kV	1.75 kV	910 V
Pollution degree	-		
Insulation resistance	>10 <sup>10</sup> Ω		
Contact resistance	<3 mΩ		
Class of flammability according to UL 94	V0		
Protection class	IP 67, in screwed condition		
Housing material	PBT black		
Contact material	CuZn, gold-plated		
Thread material	CuSn nickel plated		
Gasket	-		
Cable construction	-		
Cable jacket	-		
Conductor insulation	-		
Cable diameter	4 – 6 mm	6 – 8 mm	
Bending radius	-		
Storage temperature range	-40 °C – 90 °C		
Temperature range connector	-25 °C – 85 °C		
Termination	Screw terminal, max. 0.75 mm <sup>2</sup>	Screw terminal, max. 0.5 mm <sup>2</sup>	
Mechanical service life	>100 insertion cycles		
Weight (kg/piece)	0.040		
Approvals	-		

Accessories	Article number	Type	Outer jacket
matching cables	117243	3×0.34	PUR
	117244	4×0.34	PUR
	117245	5×0.34	PUR
	117246	5×0.34	PUR
	117242	8×0.25	PUR

## Mounting diagram

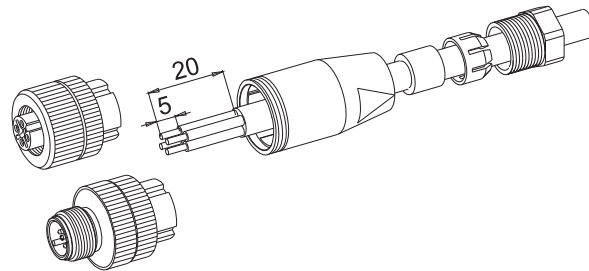



# Actuator sensor interface - M12 - connector

## Field wireable connector, M12 straight Female - A coded Screw terminal



### Dimensions

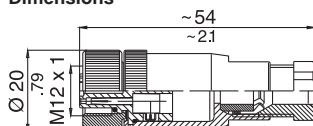

### Pin layout

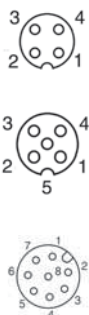

Description	Part-No.	Type	PU	
<b>Female</b>				
Pol number	4	490011	KUGK-M12 4POL SK	1
	5	490012	KUGK-M12 5POL SK	1
	8	490071	KUGK-M12 8POL SK	1

### Technical data

Technical data		Female	
Nominal voltage		AC/DC 24 V	
Nominal voltage range	250 V	125 V	60 V
Rated current	4 A		2 A
Pol number	4	5	8
Cable length (m)		-	
Status Indication		-	
Current Consumption per LED		-	
Coding		A	
Shielding		-	

### General

Form	M12 × 1, female		
Test voltage	2.95 kV	1.75 kV	910 V
Pollution degree	3		
Insulation resistance	>10 <sup>10</sup> Ω		
Contact resistance	<3 mΩ		
Class of flammability according to UL 94	V0		
Protection class	IP 67, in screwed condition		
Housing material	PBT black		
Contact material	CuZn, gold-plated		
Thread material	CuSn nickel plated		
Gasket	-		
Cable construction	-		
Cable jacket	-		
Conductor insulation	-		
Cable diameter	4 – 6 mm	6 – 8 mm	
Bending radius	-		
Storage temperature range	-40 °C – 90 °C		
Temperature range connector	-25 °C – 85 °C		
Termination	Screw terminal, max. 0.75 mm <sup>2</sup>	Screw terminal, max. 0.5 mm <sup>2</sup>	
Cross section	0.75 mm <sup>2</sup>	0.5 mm <sup>2</sup>	
Mechanical service life	>100 insertion cycles		
Weight (kg/piece)	0.040		
Approvals	-		

Accessories	Article number	Type	Outer jacket
matching cables	117243	3×0.34	PUR
	117244	4×0.34	PUR
	117245	5×0.34	PUR
	117246	5×0.34	PUR
	117242	8×0.25	PUR

### Mounting diagram

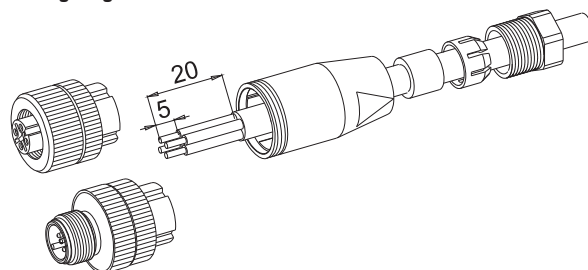

# Actuator sensor interface - M12 - connector

## Field wireable connector, M12 angled Male - A coded Screw terminal



### Dimensions

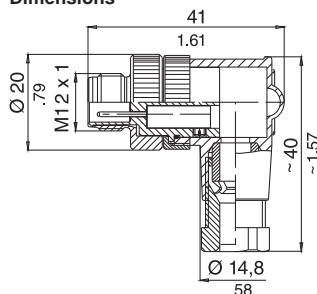

### Pin layout



Description	Part-No.	Type	PU	
<b>Male</b>				
Pol number	4	490020	STWK-M12 4POL SK	1
	5	490021	STWK-M12 5POL SK	1

Technical data		Male	
Nominal voltage		AC/DC 24 V	
Nominal voltage range	250 V		60 V
Rated current		4 A	
Pol number	4		5
Cable length (m)		-	
Status Indication		-	
Current Consumption per LED		-	
Coding		A	
Shielding		-	

General			
Form	M12 × 1, male, angled		
Test voltage	2.95 kV		1.75 kV
Pollution degree		3	
Insulation resistance		>10 <sup>10</sup> Ω	
Contact resistance		<3 mΩ	
Class of flammability according to UL 94		V0	
Protection class	IP 67, in screwed condition		
Housing material	PBT black		
Contact material	CuZn, gold-plated		
Thread material	CuSn nickel plated		
Gasket	-		
Cable construction	-		
Cable jacket	-		
Conductor insulation	-		
Cable diameter	4 – 6 mm		
Bending radius	-		
Storage temperature range	-40 °C – 90 °C		
Temperature range connector	-25 °C – 85 °C		
Termination	Screw terminal, max 0.75 mm <sup>2</sup>		
Cross section	max. 0.75 mm <sup>2</sup>		
Mechanical service life	>100 insertion cycles		
Weight (kg/piece)	0.040		
Approvals	-		
Accessories	Article number	Type	Outer jacket
matching cables	117243	3×0.34	PUR
	117244	4×0.34	PUR
	117245	5×0.34	PUR
	117246	5×0.34	PUR

### Mounting diagram

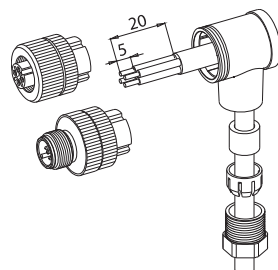

# Actuator sensor interface - M12 - connector

## Field wireable connector, M12 angled Female - A coded Screw terminal



### Dimensions

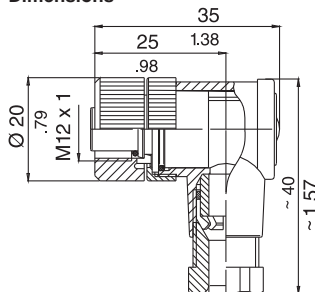

### Pin layout

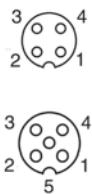

Description	Part-No.	Type	PU	
<b>Female</b>				
Pol number	4	490014	KUWK-M12 4POL SK	0
	5	490015	KUWK-M12 5POL SK	0

Technical data		Female	
Nominal voltage		AC/DC 24 V	
Nominal voltage range	250 V		60 V
Rated current		4 A	
Pol number	4		5
Cable length (m)		-	
Status Indication		-	
Current Consumption per LED		-	
Coding		A	
Shielding		-	

General			
Form		M12 × 1, female angled	
Test voltage	2.95 kV		1.75 kV
Pollution degree		3	
Insulation resistance		>10 <sup>10</sup> Ω	
Contact resistance		<3 mΩ	
Class of flammability according to UL 94		V0	
Protection class		IP 67, in screwed condition	
Housing material		PBT black	
Contact material		CuZn, gold-plated	
Thread material		CuSn nickel plated	
Gasket		NBR	
Cable construction		-	
Cable jacket		-	
Conductor insulation		-	
Cable diameter		4 – 6 mm	
Bending radius		-	
Storage temperature range		-40 °C – 90 °C	
Temperature range connector		-25 °C – 85 °C	
Termination		Screw terminal, max 0.75 mm <sup>2</sup>	
Cross section		max. 0.75 mm <sup>2</sup>	
Mechanical service life		>100 insertion cycles	
Weight (kg/piece)		0.040	
Approvals		-	

Accessories	Article number	Type	Outer jacket
matching cables	117243	3×0.34	PUR
	117244	4×0.34	PUR
	117245	5×0.34	PUR
	117246	5×0.34	PUR

### Mounting diagram

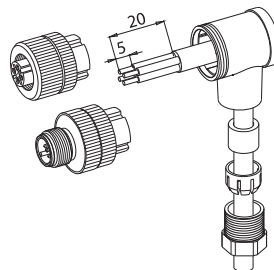

# Actuator sensor interface - M12 - connector

## Field wireable connector, M12 straight

### Male / female - A coded

### Fast connection method, IDC method of termination



#### Dimensions

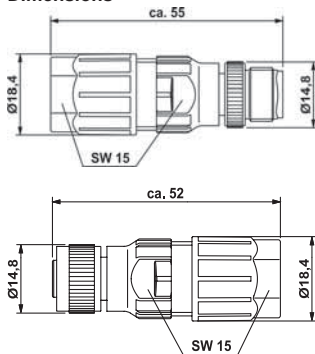

#### Pin layout

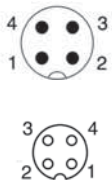

Description	Part-No.	Type	PU	
<b>Male</b>				
Pol number	4	490028	STGK-M12 4POL SNK	1
<b>Female</b>				
Pol number	4	490029	KUGK-M12 4POL SNK	1

Technical data	Male	Female
Nominal voltage		AC/DC 24 V
Nominal voltage range		250 V
Rated current		4 A
Pol number	4	
Cable length (m)		–
Status Indication		–
Current Consumption per LED		–
Coding		A
Shielding		–

General	M12 × 1, male	M12 × 1, female
Form	M12 × 1, male	M12 × 1, female
Test voltage		2.5 kV
Pollution degree		3
Insulation resistance		>10 <sup>9</sup> Ω
Contact resistance		<5 mΩ
Class of flammability according to UL 94		V0
Protection class		IP 67, in screwed condition
Housing material		PBT black
Contact material		CuZn, gold-plated
Thread material		CuSn nickel plated
Gasket	–	NBR
Cable construction		–
Cable jacket		–
Conductor insulation		–
Cable diameter		4 – 7.5 mm
Bending radius		–
Storage temperature range		-40 °C – 90 °C
Temperature range connector		-25 °C – 80 °C
Termination		IDC method of termination
Cross section		0.34–0.75 mm <sup>2</sup> mm <sup>2</sup>
Mechanical service life		>100 insertion cycles
Weight (kg/piece)		0.030
Approvals		–

Accessories	Article number	Type	Outer jacket
matching cables	117243	3×0.34	PUR
	117244	4×0.34	PUR

#### Mounting diagram

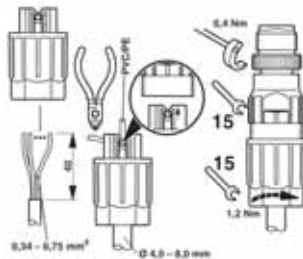

#### Mounting diagram

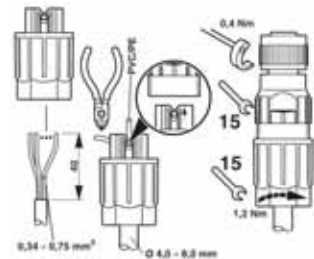

# Actuator sensor interface - M12, M12/M8 -connector

## T piece

Male M12 to 2x female M12, 5pin PIN 2+4 bridged + PE

Male M12 4pin to 2x female M8, 3pin

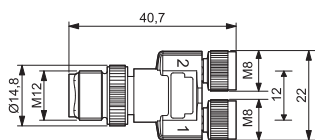
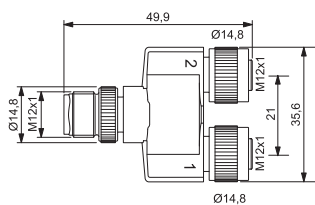

### PIN assignment

#### 490026

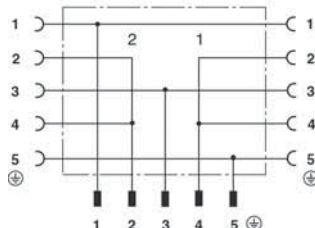

#### 490038

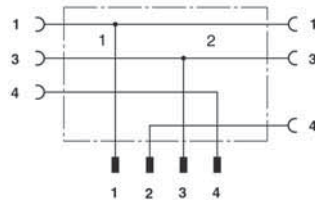

Description	Part-No.	Type	PU	
Pol number	5	490026	AST M 12/2xM 12	1
	3	490038	AST M 12/2xM 8	1

### Technical data

	490026	490038
Nominal voltage		AC/DC 24 V
Nominal voltage range	DC 60V	DC 30V
Rated current	4 A	3 A
Pol number	5	3
Cable length (m)		-
Status Indication		-
Current Consumption per LED		-
Coding		A
Shielding		-

### General

Form	M12 × 1 male / M12 × 1 female	M12 × 1 male / M8 × 1 female
Rated insulation voltage (EN 50178)		60 V
Test voltage		1.5 kV
Pollution degree		3
Insulation resistance		≥ 10 GΩ
Contact resistance		≤ 5mΩ
Class of flammability according to UL 94		HB
Protection class		-
Housing material		TPU black
Contact material		CuZn, gold plated nickel
Thread material		Zinc die-casting, nickel-plated
Gasket		NBR
Cable construction		-
Cable jacket		-
Cable diameter		-
Conductor insulation		-
Bending radius		-
Storage temperature range		-25 °C – 90 °C
Temperature range connector		-25 °C – 90 °C
Termination		-
Mechanical service life		>100 insertion cycles
Weight (kg/piece)	0.0290	0.0140
Field installation	Torque max. 0,4 Nm	Torque max. 0.4 Nm (M8 at 0.2 Nm)

### Approvals

Accessories	Article number	Type	PU
Dynamometric key M12	490090	DM-SET M8	1
Dynamometric key M12	490091	DM-SET M12	1

# Actuator sensor interface - M12 - connector

## Field wireable connector, M12 straight shielded Male / female - A coded (CAN) Screw terminal



### Dimensions

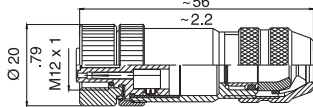
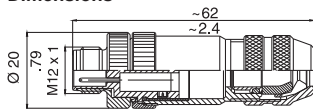

### Pin layout

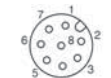

Description	Part-No.	Type	PU	
<b>Male</b>				
Pol number	4	490050	STGK4-M12 (C)-A	1
	5	490051	STGK5-M12 (C)-A	1
	8	490054	STGK8-M12 (C)-A	1
<b>Female</b>				
Pol number	4	490052	KUGK4-M12 (C)-A	1
	5	490053	KUGK5-M12 (C)-A	1
	8	490077	KUGK8-M12 (C)-A	1

### Technical data

Nominal voltage	AC/DC 24 V					
Nominal voltage range	250 V	60 V	30 V	250 V	60 V	30 V
Rated current	4 A		2 A	4 A		2 A
Pol number	4	5	8	4	5	8
Cable length (m)	-					
Status Indication	-					
Current Consumption per LED	-					
Coding	A					
Shielding	360°					

### General

Form	M12 × 1, male			M12 × 1, female		
Test voltage	2.5 kV	1.5 kV	800 V	2.5 kV	1.5 kV	800 V
Rated insulation voltage (EN 50178)	-					
Pollution degree	3					
Insulation resistance	>10 <sup>10</sup> Ω					
Contact resistance	<3 mΩ					
Class of flammability according to UL 94	HB					
Protection class	IP 67, in screwed condition					
Housing material	Zinc die-casting, nickel-plated					
Contact material	CuZn, gold-plated					
Thread material	CuSn nickel plated					
Gasket	NBR					
Cable construction	-					
Cable jacket	-					
Conductor insulation	-					
Cable diameter	6 – 8 mm					
Bending radius	-					
Storage temperature range	-40 °C – 90 °C					
Temperature range connector	-25 °C – 85 °C					
Termination	Screw terminal, max. 0.75 mm <sup>2</sup>	Screw terminal, max. 0.5 mm <sup>2</sup>	Screw terminal, max. 0.75 mm <sup>2</sup>	Screw terminal, max. 0.5 mm <sup>2</sup>		
Cross section	0.75	0.5	0.75	0.5		
Mechanical service life	>100 insertion cycles					
Weight (kg/piece)	0.045					
Approvals	-					

Accessories	Article number	Type	Outer jacket
matching cables	117253	(3×0.34)	PUR
	117254	(4×0.34)	PUR
	117255	(5×0.34)	PUR
	117252	(8×0.25)	PUR

### Comments

5-pole variant for Device Net and CAN, see bus cables

### Mounting diagram

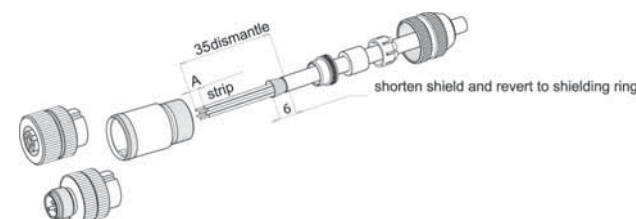

# Actuator sensor interface

## Field wireable connector, M12 shielded Female angle connector - A coded Cat 5e IDC quick-connect technology



### Dimensions

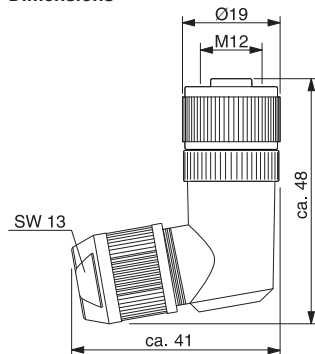

### Pin layout



Description	Part-No.	Type	PU	
Pol number	8	490089	KUW8-M12(C)-A IDC Cat.5e	1
<b>Technical data</b>				
Nominal voltage		AC/DC 24 V		
Nominal voltage range		30 V		
Rated current		1.75 A		
Pol number		8		
Cable length (m)		–		
Status Indication		–		
Current Consumption per LED		–		
Coding		AC/DC 24 V		
Shielding		360° via iris spring		
<b>General</b>				
Form		M12 × 1, female		
Rated insulation voltage (EN 50178)		30 V		
Test voltage		500 V		
Pollution degree		3		
Insulation resistance		>10 <sup>10</sup> Ω		
Contact resistance		<5 mΩ		
Class of flammability according to UL 94		V0		
Protection class		IP 67		
Housing material		Zinc die-casting, nickel-plated		
Contact material		Ni/Au		
Thread material		CuSn nickel plated		
Gasket		Neopren		
Cable construction		–		
Cable jacket		–		
Conductor insulation		–		
Cable diameter		4 – 8 mm		
Bending radius		–		
Storage temperature range		-40 °C – 90 °C		
Temperature range connector		-40 °C – 85 °C		
Termination		IDC: 0.14 – 0.34 mm <sup>2</sup> / 26 – 22 AWG		
Mechanical service life		>100 insertion cycles		
Weight (kg/piece)		0.055		
Approvals		–		
<b>Accessories</b>	<b>Article number</b>	<b>Type</b>	<b>Outer jacket</b>	
matching cables	117252	(8×0.25)	PUR	

# Actuator sensor interface - M12 - connector

## Field wireable connector, M12 straight shielded Male / female - B coded (Profibus, Interbus) Screw terminal



### Dimensions

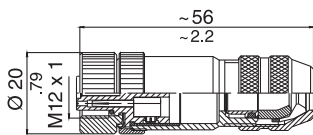
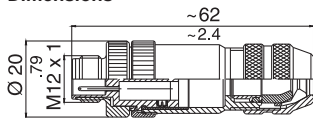

### Pin layout

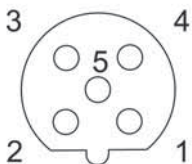
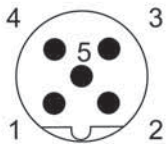

Description	Part-No.	Type	PU	
<b>Male</b>				
Pol number	5	490072	STGK5-M12 (C)-B	1
<b>Female</b>				
Pol number	5	490073	KUGK5-M12 (C)-B	1

### Technical data

Nominal voltage	AC/DC 24 V
Nominal voltage range	max. 60 V
Rated current	4 A
Pol number	5
Cable length (m)	–
Status Indication	–
Current Consumption per LED	–
Coding	B
Shielding	360°

### General

Form	M12 × 1, male	M12 × 1, female
Test voltage	1.5 kV	
Rated insulation voltage (EN 50178)	–	
Pollution degree	3	
Insulation resistance	>10 <sup>10</sup> Ω	
Contact resistance	<3 mΩ	
Class of flammability according to UL 94	HB	
Protection class	IP 67, in screwed condition	
Housing material	Zinc die-casting, nickel-plated	
Contact material	CuZn, gold-plated	CuSn, gold-plated
Thread material	CuSn nickel plated	
Gasket	NBR	
Cable construction	–	
Cable jacket	–	
Conductor insulation	–	
Cable diameter	6 – 8 mm	
Bending radius	–	
Storage temperature range	-40 °C – 90 °C	
Temperature range connector	-25 °C – 85 °C	
Termination	Screw terminal	
Cross section	max. 0.75 mm <sup>2</sup>	
Mechanical service life	>100 insertion cycles	
Weight (kg/piece)	0.040	
Approvals	–	

### Comments

suitable for Profibus and Interbus, see bus cables

### Mounting diagram

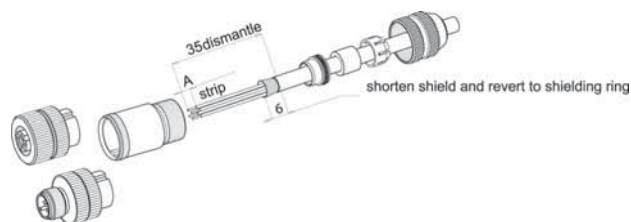



# Actuator sensor interface - M12 - connector

## Field wireable connector, M12 straight shielded Male - D coded Cat 5e (Ethernet, Profinet) Screw terminal



### Dimensions

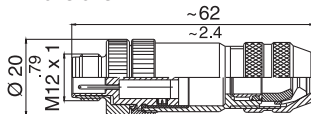

### Pin layout

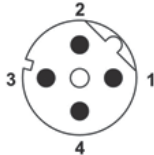

Description	Part-No.	Type	PU	
<b>Male</b>				
Pol number	4	490074	STGK4-M12 (C)-D	1
<b>Technical data</b>				
Nominal voltage		AC/DC 24 V		
Nominal voltage range		max. 60 V		
Rated current		4 A		
Pol number		4		
Cable length (m)		–		
Status Indication		–		
Current Consumption per LED		–		
Coding		D		
Shielding		360°		
<b>General</b>				
Form		M12 × 1, male		
Test voltage		2.95 kV		
Rated insulation voltage (EN 50178)		250 V		
Pollution degree		3		
Insulation resistance		>10 <sup>10</sup> Ω		
Contact resistance		<3 mΩ		
Class of flammability according to UL 94		HB		
Protection class		IP 67, in screwed condition		
Housing material		Zinc die-casting, nickel-plated		
Contact material		CuZn, gold-plated		
Thread material		CuSn nickel plated		
Gasket		NBR		
Cable construction		–		
Cable jacket		–		
Conductor insulation		–		
Cable diameter		6 – 8 mm		
Bending radius		–		
Storage temperature range		-40 °C – 90 °C		
Temperature range connector		-25 °C – 85 °C		
Termination		Screw terminal		
Cross section		without AE: 0.25–0.75 mm <sup>2</sup> with AE: 0.14–0.75 mm <sup>2</sup>		
Mechanical service life		>100 insertion cycles		
Weight (kg/piece)		0.045		
Approvals		–		
<b>Comments</b>				
suitable for Ethernet and Profinet, see bus cables				

### Mounting diagram

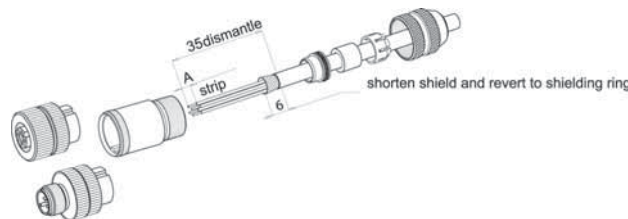

# Actuator sensor interface - M12 - connector

## Field wireable connector, M12 straight shielded Male - X coded Cat 6<sub>A</sub> (Ethernet, Profinet) IDC quick-connect technology



### Dimensions

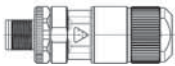
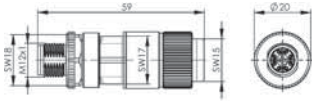

### Pin layout

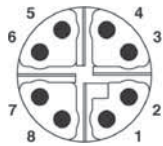

Description	Part-No.	Type	PU
<b>Male</b>			
Pol number	8	490150	STGK8-M12(C) 8pol. X-cod. Cat.6A
<b>Technical data</b>			
		<b>Male</b>	
Nominal voltage	AC/DC 48 V		
Rated current	0.5 A		
Pol number	8		
Coding	X		
Shielding	360°		
<b>General</b>			
Form	M12 × 1, male		
Pollution degree	3		
Insulation resistance	>10 <sup>10</sup> Ω		
Class of flammability according to UL 94	V0		
Contact resistance	≤5 mΩ		
Protection class	IP 67, in screwed condition		
Housing material	Zinc die-casting, nickel-plated		
Contact material	CuZn, gold-plated		
Gasket	NBR		
Strand diameter	0.9 – 1.6 mm		
Cable diameter	5.5 – 9.0 mm		
Storage temperature range	-40 – 85 °C		
Temperature range connector	-40 °C – 85 °C		
Termination	Insulation displacement connection technology		
Cross section	AWG24/1 – AWG22/1, AWG27–AWG22/7		
Mechanical service life	≥ 100 insertion cycles		
Weight (kg/piece)	0.073		
<b>Accessories</b>		<b>Article number</b>	<b>Type</b>
matching cables		104338	(4x(2xAWG26/7)St)C
		104331	(4x(2xAWG26/7)St)C
		104347	(4×2×AWG26/19) CMX

### Mounting diagram

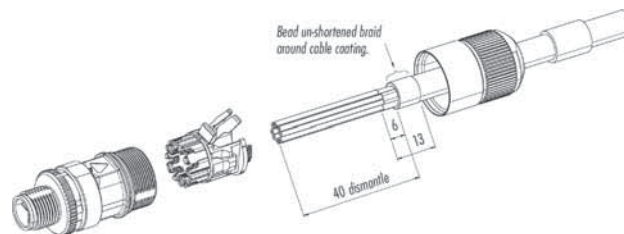

# Actuator sensor interface - M12 - connector

## Field wireable connector, M12 straight shielded Female - D coded Cat 5e (Ethernet, Profinet) Shield termination via iris spring, cage clamp



### Dimensions

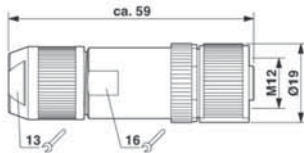

### Pin layout



Description	Part-No.	Type	PU
<b>Female</b>			
Description	Female	490095	KUGK4-M12 (C)-D
<b>Technical data</b>			
		<b>4</b>	
Nominal voltage	AC/DC 24 V		
Nominal voltage range	max. 60 V		
Rated current	Max. 4 A per contact		
Pol number	4		
Cable length (m)	-		
Status Indication	-		
Current Consumption per LED	-		
Coding	D		
Shielding	360°		
<b>General</b>			
Form	M12 × 1, female		
Rated insulation voltage (EN 50178)	60 V		
Test voltage	0.8 kV		
Pollution degree	3		
Insulation resistance	>10 <sup>10</sup> Ω		
Contact resistance	<8 mΩ		
Class of flammability according to UL 94	V0		
Protection class	IP 67, in screwed condition		
Housing material	Zinc die-casting, nickel-plated		
Contact material	CuSn, gold-plated		
Thread material	CuSn nickel plated		
Gasket	NBR		
Cable construction	-		
Cable jacket	-		
Conductor insulation	-		
Cable diameter	4 – 8 mm		
Bending radius	-		
Storage temperature range	-40 °C – 90 °C		
Temperature range connector	-40 °C – 85 °C		
Termination	Cage clamp 0.14 mm <sup>2</sup> – 0.5 mm <sup>2</sup> / 26 AWG – 20 AWG		
Mechanical service life	≥ 100 insertion cycles		
Weight (kg/piece)	0.042		
Approvals	-		

### Comments

suitable for Ethernet and Profinet, see bus cables

### Mounting diagram

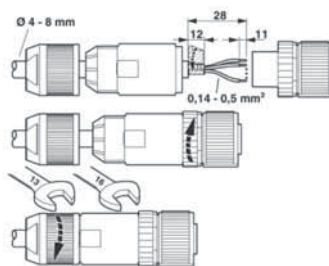

# Actuator sensor interface - RJ45 connector

## Industrial connector RJ45

solid metal housing, quick-connect technology AWG 27–22

Cat 6<sub>A</sub>



### Dimensions

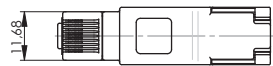
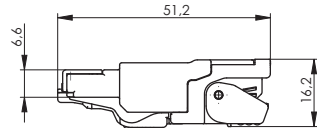

### Connection assignment

490128

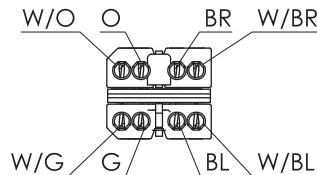

490129, 490138

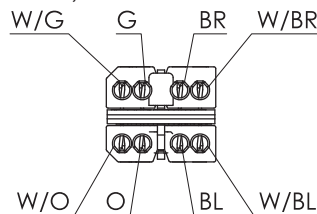

Description	Part-No.	Type	PU	
Description	Connection according to TIA 568 B	490128	RJ45-M 8pol. Cat.6A T568B	1
	Connection according to TIA 568 A	490129	RJ45-M 8pol. Cat.6A T568A	1
	Connection according to TIA 568 B	490138	RJ45-M 8pol. Cat.6A T568B AWG26	1

Technical data	490128	490129	490138
Nominal voltage		30 V	
Nominal voltage range		–	
Rated current		Max. 1.0 A per contact	
Pol number		8	
Cable length (m)		–	
Transmission frequency		10 Gigabit/s	
Category		6 <sub>A</sub> (ISO/IEC 11801, DIN EN 50173-1)	
Contact type		Penetration contacts	
Shielding		yes	
<b>General</b>			
Form		RJ45 (IEC 60603-7-51)	
Rated insulation voltage (EN 50178)		–	
Test voltage		–	
Pollution degree		1	
Insulation resistance		≥500 MΩ	
Contact resistance		≤20 mΩ	
Class of flammability according to UL 94		V0	
Protection class		IP 20	
Housing material		Zinc die-casting, nickel-plated/PBT black	
Coverage		PBT black	
Contact material		Spring steel 0.8 μm gold-plated	
Field installation		–	
Installation depth		–	
Strand diameter		0.85 – 1.6 mm	0.85 – 1.1 mm
Cable construction		–	
Cable jacket		–	
Cable diameter		5 – 9 mm	
Cross section		AWG 24/1-22/1, AWG 27/7-22/7	AWG 26/1, AWG 26/7, AWG 26/19
Operation temperature range		–40 °C – 70 °C	
Storage temperature range		–40 °C – 70 °C	
Mechanical service life		≥ 750 insertion cycles	
Dimensions (w × h × d)		13.8 × 16.2 × 53.1 mm	
Weight (kg/piece)		0.025	
Approvals		cULus	
Standards		IEC 60603-7-51	

### Comments

Suitable for Profinet, SERCOS3, Ethercat, Ethernet/IP, Powerlink, VARAN, Power over Ethernet+ (PoE+IEEE 802.3at)  
 Item 490138 specifically suited to Ethernet C-track cables AWG 26/19 (104347, 104326, 104310).  
 Item 490128, 490129 suitable for LÜTZE C-track cables: 104332, 104304, 104245.

# Actuator sensor interface - RJ45 connector

Industrial connector RJ45, angled  
solid metal housing, quick-connect technology AWG 27–22  
Cat 6A



### Dimensions

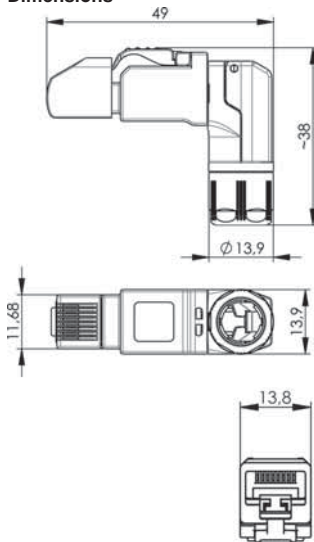

### Connection assignment

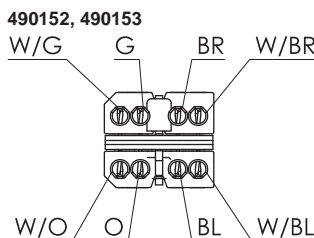
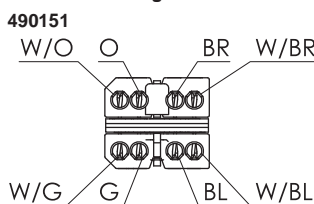

Description	Part-No.	Type	PU	
Description	Connection according to TIA 568 B	490151	RJ45-X 8pol. Cat.6A T568B	1
	Connection according to TIA 568 A	490152	RJ45-X 8pol. Cat.6A T568A	1
	Connection according to TIA 568 B	490153	RJ45-X 8pol. Cat.6A T568B AWG26	1

Technical data	490151	490152	490153
Nominal voltage		30 V	
Nominal voltage range		–	
Rated current		Max. 1.0 A per contact	
Pol number		8	
Cable length (m)		–	
Transmission frequency		10 Gigabit/s	
Category		6A (ISO/IEC 11801, DIN EN 50173-1)	
Contact type		Penetration contacts	
Shielding		yes	
<b>General</b>			
Form		RJ45 (IEC 60603-7-51), cable output 90° rotating	
Rated insulation voltage (EN 50178)		–	
Test voltage		–	
Pollution degree		1	
Insulation resistance		≥500 MΩ	
Contact resistance		≤20 mΩ	
Class of flammability according to UL 94		V0	
Protection class		IP 20	
Housing material		Zinc die-casting, nickel-plated/PBT black	
Coverage		PBT black	
Contact material		Spring steel 0.8 μm gold-plated	
Field installation		–	
Installation depth		–	
Strand diameter		1.0 – 1.6 mm	0.85 – 1.1 mm
Cable construction		–	
Cable jacket		–	
Cable diameter		5 – 9 mm	
Cross section		AWG 24/1-22/1, AWG 27/7-22/7	AWG 26/1-24/1, AWG 27/7-24/7, AWG 26/19
Operation temperature range		–40 °C – 85 °C	
Storage temperature range		–40 °C – 85 °C	
Mechanical service life		≥ 750 insertion cycles	
Dimensions (w × h × d)		13.9 × 41.0 × 45.7 mm	
Weight (kg/piece)		0.030	
Approvals		cULus	
Standards		IEC 60603-7-51	

### Comments

Suitable for Profinet, SERCOS3, Ethercat, Ethernet/IP, Powerlink, VARAN, Power over Ethernet+ (PoE+IEEE 802.3at)  
Art. 490153 suitable for LÜTZE C-track cables AWG 26/19: 104347, 104326, 104310.  
Item 490151, 490152 suitable for LÜTZE C-track cables: 104332, 104304, 104245.

### Mounting diagram

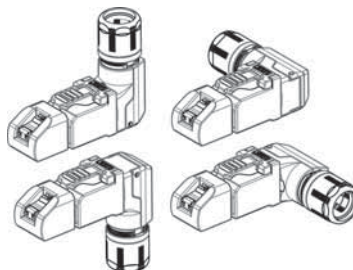

# Interface Technology - Ethernet connectivity

## Module holder, RJ45, female / IDC For TS35 DIN rail Cat 6



### Dimensions

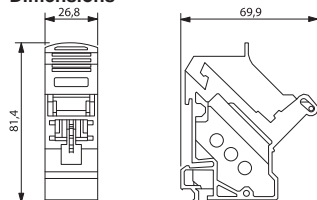

### Connection assignment

	TIA 568A	TIA 568 B	Profinet
1	WHGN	WHOG	YE
2	GN	OG	OG
3	WHOG	WHGN	WH
4	BU	BU	-
5	WHBU	WHBU	-
6	OG	GN	BU
7	WHBR	WHBR	-
8	BR	BR	-

Description	Part-No.	Type	PU	
<b>Suitable for Ethernet applications</b>				
Description	8-pin	772104	MDT-RJ45 F Cat.6	1
<b>Technical data</b>				
		<b>772104</b>		
Nominal voltage	30 V			
Nominal voltage range	-			
Rated current	Max. 1.0 A per contact			
Pol number	8			
Cable length (m)	-			
Transmission frequency	250 MHz			
Category	6			
Contact type	IDC			
Shielding	yes			
<b>General</b>				
Form	RJ45			
Rated insulation voltage (EN 50178)	-			
Test voltage	-			
Pollution degree	1			
Insulation resistance	≥100 MΩ			
Contact resistance	≤50 mΩ			
Class of flammability according to UL 94	V0			
Protection class	IP 20			
Housing material	PC-GF grey			
Contact material	CuSn, gold-plated			
Field installation	-			
Installation depth	-			
Cable construction	-			
Cable jacket	-			
Cable diameter	4.5 – 8 mm			
Cross section	AWG 24-22			
Operation temperature range	-10 °C – 60 °C			
Storage temperature range	-40 °C – 70 °C			
Mechanical service life	≥ 750 insertion cycles			
Dimensions (w × h × d)	36.0 × 36.0 × 27.5 mm			
Weight (kg/piece)	0.063			
Approvals	-			
Standards	-			
<b>Accessories</b>				
Patch cable RJ45 Cat.5e	192000.xxxx	xxxx cable length from 0.5 - 30 m	1	
Patch cable RJ45 Cat.6e	192100.xxxx	xxxx cable length from 0.5 - 30 m	1	

# Actuator sensor interface - M8 panel jack

## M8 panel connectors using M8 thread Male / female 0.5 m TPE wire



### Dimensions

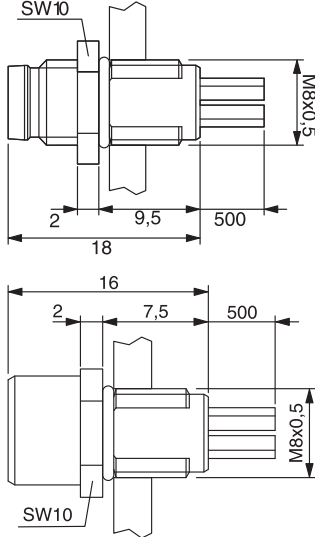

### Pin layout

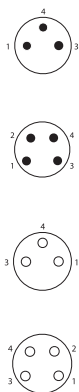

### Mounting diagram

assembling board with through bore-hole  
2:1

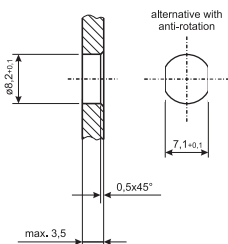

Description	Part-No.	Type	PU	
<b>Male</b>				
Pol number	3	490062	STGE3-M8 0,5m	1
	4	490063	STGE4-M8 0,5m	1
<b>Female</b>				
Pol number	3	490060	KUGE3-M8 0,5m	1
	4	490061	KUGE4-M8 0,5m	1
<b>Technical data</b>				
	<b>Male</b>		<b>Female</b>	
Nominal voltage	AC/DC 24 V			
Nominal voltage range	max. 60 V	max. 30 V	max. 60 V	max. 30 V
Rated current	4 A			
Pol number	3	4	3	4
Cable length (m)	0.5			
Status Indication	-			
Current Consumption per LED	-			
Coding	-			
Shielding	-			
<b>General</b>				
Form	M8 × 1, male		M8 × 1, female	
Test voltage	1.5 kV	0.8 kV	1.5 kV	0.8 kV
Pollution degree	3			
Insulation resistance	≥100 MΩ			
Contact resistance	≤3 mΩ			
Class of flammability according to UL 94	HB			
Protection class	IP 67, in screwed condition			
Housing material	Zinc die-casting, nickel-plated			
Contact material	CuZn, gold-plated			
Thread material	CuSn nickel plated			
Gasket	-		NBR	
Cable construction	Individual wires: 0.25 mm <sup>2</sup> (14×0.15 mm)			
Cable jacket	-			
Conductor insulation	TPE-wire, colored			
Cable diameter	-			
Bending radius	-			
Storage temperature range	-40 °C – 90 °C			
Temperature range connector	-25 °C – 85 °C			
Termination	Thread M8			
Cross section	3×0.25 mm <sup>2</sup>	4×0.25 mm <sup>2</sup>	3×0.25 mm <sup>2</sup>	4×0.25 mm <sup>2</sup>
Mechanical service life	>100 insertion cycles			
Weight (kg/piece)	0.012	0.014	0.012	0.014
Approvals	-			

### Comments

Included in scope of delivery: M8 lock nut

### Connection assignment

#### Pole / wire color:

- 1/ BN (brown)
- 3/ BU (blue)
- 4/ BK (black)

- 1/ BN (brown)
- 2/ WH (white)
- 3/ BU (blue)
- 4/ BK (black)

# Actuator sensor interface - M12 panel jack

## M12 connectors panel mounted using M16 thread

### Male / female - A coded

### 0.5 m TPE wire



#### Dimensions

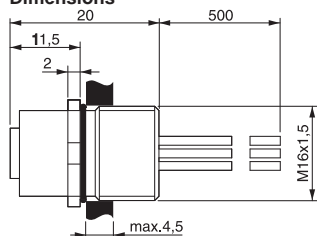

#### Pin layout

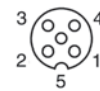

#### Mounting diagram

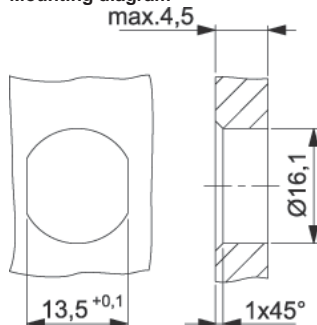

Description	Part-No.	Type	PU	
<b>Male</b>				
Pol number	4	490067	STGE4-M12 0,5m	1
	5	490068	STGE5-M12 0,5m	1
	8	490069	STGE8-M12 0,5m	1
<b>Female</b>				
Pol number	4	490064	KUGE4-M12 0,5m	1
	5	490065	KUGE5-M12 0,5m	1
	8	490066	KUGE8-M12 0,5m	1

Technical data	Male			Female		
Nominal voltage	AC/DC 24 V					
Nominal voltage range	max. 250 V	max. 60 V	max. 30 V	max. 250 V	max. 60 V	max. 30 V
Rated current	4 A		2 A	4 A		2 A
Pol number	4	5	8	4	5	8
Cable length (m)	0.5					
Status Indication	-					
Current Consumption per LED	-					
Coding	A					
Shielding	-					
<b>General</b>						
Form	M12 × 1, male			M12 × 1, female		
Test voltage	2.5 kV	1.5 kV	800 V	2.5 kV	1.5 kV	800 V
Pollution degree	3					
Insulation resistance	≥100 MΩ					
Contact resistance	≤3 mΩ					
Class of flammability according to UL 94	V0					
Protection class	IP 67, in screwed condition					
Housing material	Zinc die-casting, nickel-plated					
Contact material	CuZn, gold-plated					
Thread material	CuSn nickel plated					
Gasket	-			NBR		
Cable construction	Individual wires: 0.34 mm <sup>2</sup> (7×0.25 mm) / 0.25 mm <sup>2</sup> (14×0.15 mm)					
Cable jacket	-					
Conductor insulation	TPE-wire, colored					
Cable diameter	0,34 mm <sup>2</sup> : 1.25 mm / 0.25 mm <sup>2</sup> : 1.15 mm					
Bending radius	-					
Storage temperature range	-40 °C – 90 °C					
Temperature range connector	-25 °C – 90 °C					
Termination	Thread M16					
Cross section	4×0.34 mm <sup>2</sup>	5×0.34 mm <sup>2</sup>	8×0.25 mm <sup>2</sup>	4×0.34 mm <sup>2</sup>	5×0.34 mm <sup>2</sup>	8×0.25 mm <sup>2</sup>
Mechanical service life	>100 insertion cycles					
Weight (kg/piece)	0.020	0.021	0.025	0.020	0.021	0.025

Approvals	-		
<b>Accessories</b>	<b>Article number</b>	<b>Type</b>	<b>PU</b>
Counter nut M16	600361	GMS M 16 × 1.5	100

#### Comments

##### Connection assignment

##### Pole / wire color:

- 1/ BN (brown)
- 2/ WH (white)
- 3/ BU (blue)
- 4/ BK (black)

- 1/ BN (brown)
- 2/ WH (white)
- 3/ GN (green)
- 4/ YE (yellow)
- 5/ GY (grey)
- 6/ PK (pink)
- 7/ BU (blue)
- 8/ RD (red)



# Actuator sensor interface - USB-panel connector

**USB 3.0 panel connector with M22 thread for front installation**  
**USB connector Type A on straight USB plug Type A with PVC cable**  
**Type: USB-3.0 A/A**



Description	Part-No.	Type	PU
<b>USB 3.0</b>			
Cable length (m)	0.3	490113.0030	USB-3.0 A/A F/M 0,3M PVC
	0.6	490113.0060	USB-3.0 A/A 0,6M PVC
	0.8	490113.0080	USB-3.0 A/A 0,8M PVC
	1.5	490113.0150	USB-3.0 A/A 1,5M PVC
	2.0	490113.0200	USB-3.0 A/A 2,0M PVC
	3.0	490113.0300	USB-3.0 A/A 3,0M PVC
	5.0	490113.0500	USB-3.0 A/A 5,0M PVC

Technical data	USB 3.0
Nominal voltage	AC/DC 5 V
Nominal voltage range	max. 30 V
Rated current	900 mA
Pol number	9
Cable length (m)	0.3 0.6 0.8 1.5 2.0 3.0 5.0
Transfer rate	5 Gbit/s
USB standard	3.0
Contact type	1 : 1
Shielding	yes

General	USB-A
Form	USB-A
Test voltage	-
Pollution degree	3
Insulation resistance	>100 MΩ
Contact resistance	<30 mΩ

Class of flammability according to UL 94	-
Protection class	IP 65 and UL NEMA Typ 12 65 in closed and IP 20 in inserted condition
Housing material	Female: PA; Male: PVC, Coverage: TPU
Contact material	CuSn, gold-plated
Field installation	Front plate cutout D=22.5mm
Cable construction	(2×AWG24 + 1×2×AWG28 + 2×(1×2×AWG28)St)StC
Cable jacket	PVC black
Cable diameter	6.1 mm
Bending radius	6 x cable diameter
Storage temperature range	-
Temperature range cable moving	-5 °C – 70 °C
Temperature range cable fixed	-25 °C – 80 °C
Operation temperature range	-5 °C – 70 °C
Temperature range connector	-
Mechanical service life	>100 insertion cycles
Dimension	(D×T) 29.5 × 45 mm, installation depth appr. 70 mm
Weight (kg/piece)	0.046 0.058 0.066 0.094 0.113 0.152 0.232
Approvals	cULus

**Comments**  
 Included in the delivery: captive safety cap

## Dimensions

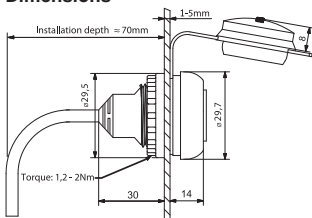

## PIN assignment

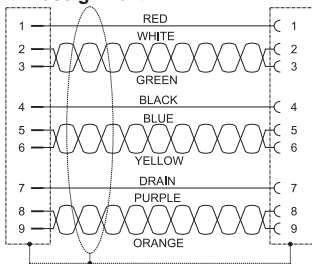

## Mounting diagram

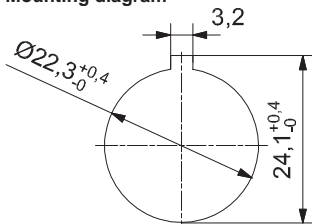

## Front view

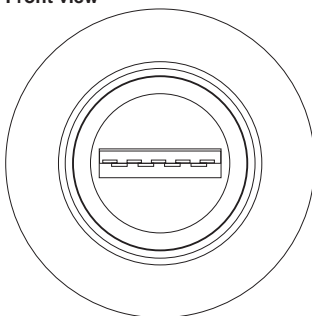

# Actuator sensor interface - USB-panel connector

USB 3.0 panel connector with M22 thread for front installation  
 USB 3.0 female / female Type A/A  
 Typ: UBS-3.0 A/A F/F



Description	Part-No.	Type	PU
USB 3.0	490112	USB-3.0 A/A F/F	1

Technical data		USB 3.0
Nominal voltage		AC/DC 5 V
Nominal voltage range		max. 30 V
Rated current		900 mA
Pol number		9
Cable length (m)		–
Transfer rate		5 Gbit/s
USB standard		3.0
Contact type		1 : 1
Shielding		yes

General	
Form	USB 3.0 Female/Female Type A/A
Test voltage	–
Pollution degree	3
Insulation resistance	>100 MΩ
Contact resistance	<30 mΩ
Class of flammability according to UL 94	–
Protection class	IP 65 and UL NEMA Typ 12 65 in closed and IP 20 in inserted condition
Housing material	Female: PA, PVC, Coverage, TPU
Contact material	CuSn, gold-plated
Field installation	Front plate cutout D=22.5mm
Cable construction	–
Cable jacket	–
Cable diameter	–
Bending radius	–
Storage temperature range	-25 °C – 80 °C
Operation temperature range	-20 °C – 70 °C
Temperature range connector	–
Mechanical service life	>100 insertion cycles
Dimension	(D×T) 29.5 × 42.5 mm, installation depth appr. 100 mm
Weight (kg/piece)	0.009
Approvals	cULus

**Comments**  
 Included in the delivery: captive safety cap

## Dimensions

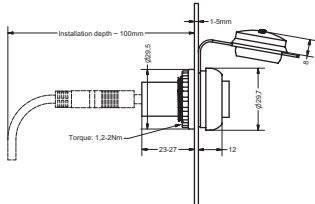

## PIN assignment

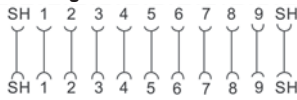

## Mounting diagram

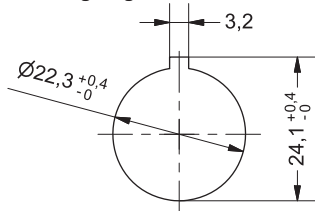

front view

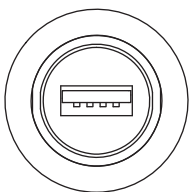

# Actuator sensor interface - RJ45 panel connector

RJ45 panel connector for front installation 22.5 mm  
female/female 1:1  
Cat 5e/6



## Dimensions

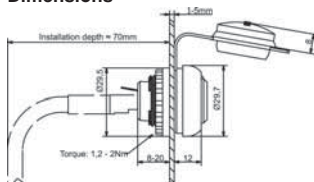

## Circuit diagram

### 492075

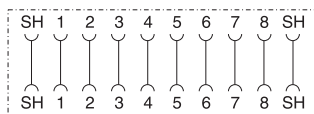

### 491075

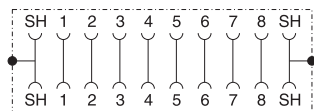

## Mounting diagram

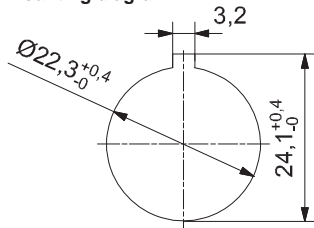

front view:

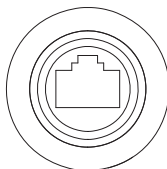

Description	Part-No.	Type	PU
<b>Category</b>			
Cat.5e	492075	RJ45 F/F 8/8 Cat.5e	1
Cat.6	491075	RJ45 F/F 8/8 Cat.6	1
<b>Technical data</b>	<b>492075</b>	<b>491075</b>	
Nominal voltage		AC 24 V	
Nominal voltage range	AC 50 V		AC 150 V
Rated current		1.5 A	
Pol number		8	
Cable length (m)		-	
Rate of transmission	100 MHz		250 MHz
Category	5e		6
Contact type		1 : 1	
Shielding	shield connected through		360° shielding
Coding		-	
<b>General</b>			
Form		RJ45	
Rated insulation voltage (EN 50178)		-	
Test voltage		-	
Pollution degree		3	
Insulation resistance		≥100 MΩ	
Contact resistance		≤30 mΩ	
Class of flammability according to UL 94		V0	
Protection class		IP 65 and NEMA UL Type 12 in closed and IP 20 in inserted condition	
Housing material		PA-GF25; PBT Gf20; Coverage TPU	
Coverage		TPU	
Contact material		CuSn, gold-plated	
Field installation		Front plate cutout D=22.5mm	
Installation depth		approx. 70 mm	
Cable construction		8 (4-pair)	
Cable jacket		-	
Cable diameter		-	
Bending radius		-	
Operation temperature range		-25 °C – 70 °C	
Storage temperature range		-25 °C – 80 °C	
Mechanical service life		<750 insertion cycles	
Dimension		(?×D) 29.5 × 29 mm	
Weight (kg/piece)		0.016	
Approvals		cULus	
Standards		-	

# Actuator sensor interface - RJ45 panel connector

## Control cabinet bushing M12 - RJ45 female/female 1:1 Cat 5e (Ethernet, Profinet)



### Dimensions

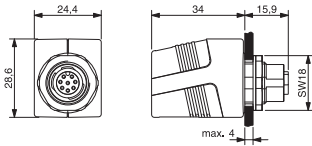

### Circuit diagram

#### 490105, 490106

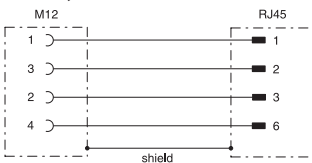

#### 490107, 490108

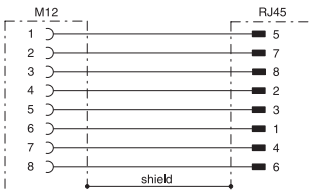

### Mounting diagram

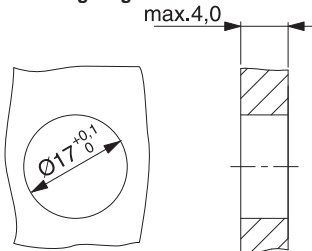

Description	Part-No.	Type	PU
4 pole 90°	490105	M12-R45 F/F 90° 4/4 Cat.5e PROFINET	1
4 pole 180°	490106	M12-R45 F/F 180° 4/4 Cat.5e PROFINET	1
8 pole 90°	490107	M12-R45 F/F 90° 8/8 Cat.5e	1
8 pole 180°	490108	M12-R45 F/F 180° 8/8 Cat.5e	1

Technical data	490105	490106	490107	490108
Nominal voltage			24 V	
Nominal voltage range			50 V	
Rated current		max. 1 A per contact		
Pol number	4		8	
Cable length (m)			–	
Rate of transmission		100 Mbit/s		1 Gbit/s
Category	5e			6
Contact type			1 : 1	
Shielding		360° shielding		
Coding	D			A

### General

Form	RJ45 / M12 x 1		
Rated insulation voltage (EN 50178)	–		
Test voltage	–		
Pollution degree	3		
Insulation resistance	≥100 MΩ		
Contact resistance	≤30 mΩ		
Class of flammability according to UL 94	V0		
Protection class	IP 67 in screwed condition		
Housing material	PA		
Coverage	–		
Contact material	Phosphor bronze, gold-plated		
Field installation	–		
Installation depth	approx. 70 mm		
Cable construction	–		
Cable jacket	–		
Cable diameter	–		
Bending radius	–		
Operation temperature range	-25 °C – 85 °C		
Storage temperature range	-25 °C – 85 °C		
Mechanical service life	≥ 750 insertion cycles		
Dimension	(×D) 29.5 × 29 mm		
Weight (kg/piece)	0.037		
Approvals	–		
Standards	–		

# Actuator sensor interface

**Protective coverage**  
**M8, M12**  
**Color: black**



Description	Part-No.	Type	PU
Color	black	SK M 8	50
	black	SK M 12	50
<b>General</b>	<b>499989</b>	<b>499994</b>	
Housing material		PA	
Color		black	
Class of flammability according to UL 94		V0	
Surface		–	
Termination	M8 × 1		M12 × 1
Storage temperature range		-20 – 80 °C	
Operation temperature range		-20 – 80 °C	
Dimensions (w × h × d)			
Weight (kg/piece)		0.0020	
Wire		–	

# Actuator sensor interface

Designation unit for M8, M12 cables  
 Designation plate, designation sleeve  
 Color: white, transparent



Description	Part-No.	Type	PU	
Color	white	499988	LB M8/M12 4×23 mm	200
	white, printed	499996	LB M8/M12 4×23 mm	20
	transparent	499993	LBT M8/M12 D/2-4 mm	500
	transparent	499995	LBT M8/M12 D/4-7 mm	500

General	499988	499996	499993	499995
Housing material	Ultradur B4520		PVC	
Color	white	white, printed	transparent	
Class of flammability according to UL 94	V2		V0	
Surface	smooth			
Termination	-			
Storage temperature range	-50 – 80 °C			
Operation temperature range	-50 – 80 °C			
Dimensions (w × h × d)	4.0 × 23.0 mm		8.0 × 23.5 × 13.0 mm	
Weight (kg/piece)	0.0050		0.0030	
Wire	-		Ø 2-4mm	Ø 4-7mm

**Comments**

Printing for article No.499996 according to customer specification max. of 14 characters

**Dimensions**

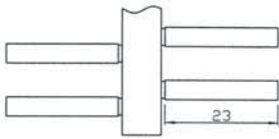

# Classification Ethernet Cable and - connector

## Connector RJ45 and M12



RJ45 Connector straight

page 7.62



RJ45 Connector angled

page 7.63



M12 Connector D coded

page 7.59



M12 Connector X coded

page 7.60

Connector	RJ45 T568B Part-No. 490129 / 490152					RJ45 T568A Part-No. 490128 / 490151					RJ45 T568B AWG26 Part-No. 490138 / 490153					M12 D coded Part-No. 490074					M12 X-coded Part-No. 490150				
	Cat 6 <sub>A</sub>					Cat 6 <sub>A</sub>					Cat 6 <sub>A</sub>					Cat 5e					Cat 6 <sub>A</sub>				
	Profinet, 2 and 4-pair, AWG 22	Ethercat, 2-pair, AWG 22-26	SERCOS, 2-pair, AWG 22	Ethernet/IP, 2 and 4-pair, AWG 22-26	Powerlink, 2-pair, AWG 22	Profinet, 2 and 4-pair, AWG 22	Ethercat, 2-pair, AWG 22-26	SERCOS, 2-pair, AWG 22	Ethernet/IP, 2 and 4-pair, AWG 22-26	Powerlink, 2-pair, AWG 22	Profinet, 2 and 4-pair, AWG 22	Ethercat, 2-pair, AWG 22-26	SERCOS, 2-pair, AWG 22	Ethernet/IP, 2 and 4-pair, AWG 22-26	Powerlink, 2-pair, AWG 22	Profinet, 2 und 4 paarig, AWG 22	Ethercat, 2-pair, AWG 22-26	SERCOS, 2-pair, AWG 22	Ethernet/IP, 2 and 4-pair, AWG 22-26	Powerlink, 2-pair, AWG 22	Profinet, 2 and 4-pair, AWG 22	Ethercat, 2-pair, AWG 22-26	SERCOS, 2-pair, AWG 22	Ethernet/IP, 2 and 4-pair, AWG 22-26	Powerlink, 2-pair, AWG 22
<b>Cables</b>																									
Part-No. 104301 (2x2AWG22/1)StC	5	•	•	•	•	•	•	•	•	•					•	•	•	•	•						
Part-No. 104302 (2x2AWG22/19)StC	•	5	•	•	•	•	•	•	•	•					•	•	•	•	•						
Part-No. 104303 (2x2AWG22/7)StC	•	5	•	•	•	•	•	•	•	•					•	•	•	•	•						
Part-No. 104307 (2x2AWG22/7)StC	5	•	•	•	•	•	•	•	•	•					•	•	•	•	•						
Part-No. 104331 (4x(2xAWG26/7)St)C															•										•
Part-No. 104335 (4x2xAWG26/7)StC															•										•
Part-No. 104336 (4x2xAWG24/7)StC					•				•																•
Part-No. 104337 (4x2xAWG24/19)StC	•	5e			•				•																•
Part-No. 104338 (4x(2xAWG26/7)St)C		6 <sub>A</sub>													•										•
Part-No. 104347 (4x2xAWG26/19)	•	6													•										•
Part-No. 104379 (2x2xAWG26/19)	•	5e													•	•			•						
Part-No. 104396 (4x2xAWG26/19)StC	•	5e													•										•
Part-No. 104397 (4x(2xAWG22/1)St)C		6 <sub>A</sub>	•		•		•		•													•			•





## 8. Suppression Technology



## 8. Suppression technology



### Suppressor for switch gear, universal suppressor module

Enclosure: S7A	8.3
Enclosure: S1, S2	8.4
Enclosure: V1	8.5
Enclosure: VM1, V2	8.6
Enclosure: S6 (SIEMENS, AEG, EATON)	8.7
Switch size: S00 (SIEMENS 3RT1...) with or without LED	8.8 - 8.9
Switch size: S12, 13 (SIEMENS 3RT...)	8.10



### Valve connector with cable

Valve connector Deutsch DT06-2S, with or without jacket	8.11 - 8.12
Valve connector AMP Junior Timer, with or without jacket	8.13 - 8.14
Design A (18 mm)	8.15 - 8.19
Design A (18 mm) with special function	8.20 - 8.22
Design B (10 mm)	8.23
Design BI (11 mm)	8.24
Design C (8 mm)	8.25
Design CI (9,4 mm)	8.26



### Valve connector, adjustable

Design A (18 mm)	8.27 - 8.28
Design A (18 mm) with special function	8.29 - 8.32
Design B (10 mm) and BI (11 mm)	8.33 - 8.34
Design B (10 mm) and BI (11 mm) with special function	8.35
Design C (8 mm) and CI (9,4 mm)	8.36



### Valve suppressor plug-in adapter

Design A (18 mm)	8.37
Design BI (11 mm)	8.38

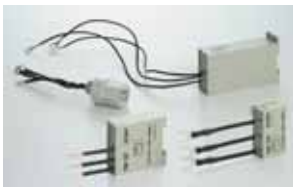

### Motor suppression

Installation in the motor terminal board	8.39 - 9.42
Attachment to contactor	8.43 - 8.44
Mounting under contactor	8.45 - 8.46



### Components with special function

Adjustable switch-on delay enclosure: S2, V1	8.47
----------------------------------------------	------

# Suppression Technology - Suppressor for Switch Gear

## Universal Suppressor Module

Enclosure type: S7A

Protection device: RC combination



### Dimensions

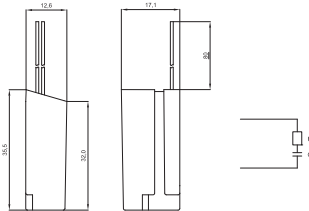

### PIN assignment



Description	Part-No.	Type	PU	
Nominal voltage	AC 115 / 230 V	706161	LRC-S7A-6161 AC 230 V 10 VA	10
<b>Technical data</b>		<b>706161</b>		
Function type	Suppressor for Switch Gear			
Protection device	RC combination			
Nominal voltage	AC 115 / 230 V			
Shut-off points	-			
Rated frequency	50-60 Hz			
Inverse voltage/switching current	-			
Holding capacitance	10 VA			
Type of connecting lead	-			
Length of connecting lead (M)	-			
Termination	2 open cable ends AWG 22 / 80 mm / black			
<b>General</b>				
Form	S7A			
Pottant	-			
Housing material	PPE/SB			
Protection class	IP 67			
Field installation	Cable ties are used for fastening to the harness			
Operation temperature range	0 °C - 60 °C			
Storage temperature range	-			
Dimensions (w × h × d)	17.1 × 35.5 × 12.6 mm			
Weight (kg/piece)	0.010			
Standards	-			
Approvals	cURus, VDE			

# Suppression Technology - Suppressor for Switched Gear

## Universal Suppressor Module

Enclosure type: S1, S2

Protection device: Diode / Varistor / RC module

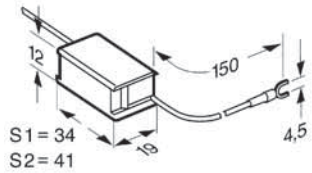

### PIN assignment

700445, 700446



700440



700414, 700413



Description	Part-No.	Type	PU	
<b>Diode</b>				
Nominal voltage	DC 24–230 V	700445	LD-S1-0445 DC 230 V 1 A	10
	DC 24–230 V	700446	LD-S1-0446 DC 230 V 3 A	10
<b>varistor</b>				
Nominal voltage	AC/DC 24 V	700440	LV-S1-0440 AC/DC 24 V 60 VA	10
<b>RC module</b>				
Nominal voltage	AC 115–230 V	700414	LRC-S2-0414 AC 230V 10VA	10
	AC 115–230 V	700413	LRC-S2-0413 AC 230V 20VA	10

Technical data	700445	700446	700440	700414	700413
Function type	Suppressor for Switch Gear				
Protection device	Diode		varistor	RC module	
Nominal voltage	DC 24–230 V		AC/DC 24 V	AC 115–230 V	
Shut-off points	≤1 V		≤52 V	–	
Rated frequency	–		–	50–60 Hz	
Inverse voltage/switching current	1600 V / 1 A	1300 V / 3 A	–	–	
Holding capacitance	–		60 VA	10 VA	20 VA
Type of connecting lead	–		LIY 0.5 mm <sup>2</sup>		
Length of connecting lead (M)	–		0.15 M		
Termination	Fork-type cable lug M4				

### General

Form	S1		S2		
Status Indication	–				
Housing material	PPO				
Protection class	IP 67				
Field installation	Insert in the rail profile or attach with retaining clips to the connection wires. (Accessories)				
Operation temperature range	0 °C – 60 °C				
Storage temperature range	-20 °C – 80 °C				
Dimensions (w × h × d)	34.0 × 19.0 × 12.0 mm		41.0 × 19.0 × 12.0 mm		
Weight (kg/piece)	0.010		0.014		
Standards	–				
Approvals	cURus				

Accessories	Color	Article number	Description	PU
Retaining clip for type S1	transparent	700409	For the mounting to the connection wires	100
Retaining clip for type S2	transparent	700419	For the mounting to the connection wires	100

### Mounting diagram

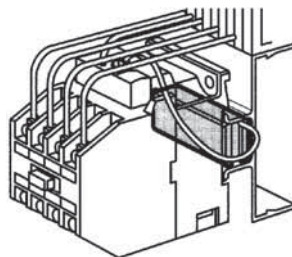

### Mounting diagram

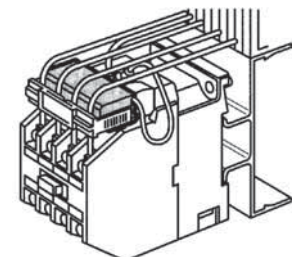

# Suppression Technology - Suppressor for Switched Gear

## Universal Suppressor Module

Enclosure type: V1

Protection device: Diode / Varistor / RC module

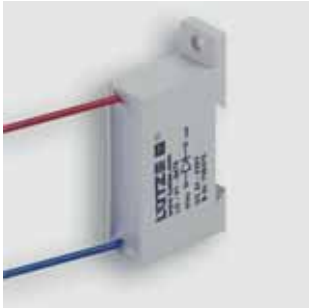

### Dimensions

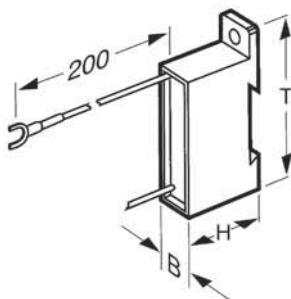

### PIN assignment

700475, 700476



700577, 700568, 700435



700466



Description	Part-No.	Type	PU			
<b>Diode</b>						
Nominal voltage	DC 24–230 V	700475	LD-V1-0475 DC 230 V 1 A	10		
	DC 24–230 V	700476	LD-V1-0476 DC 230 V 3 A	10		
<b>varistor</b>						
Nominal voltage	AC/DC 24 V	700577	LV-V1-0577 AC/DC 24 V 200 VA	10		
	AC/DC 60–115 V	700568	LV-V1-0568 AC/DC 115 V 200 VA	10		
	AC/DC 230 V	700435	LV-V1-0435 AC/DC 230 V 200 VA	10		
<b>RC module</b>						
Nominal voltage	AC 115–230 V	700466	LRC-V1-0466 AC 230 V 30 VA	10		
<b>Technical data</b>						
	<b>700475</b>	<b>700476</b>	<b>700577</b>	<b>700568</b>	<b>700435</b>	<b>700466</b>
Function type	Suppressor for Switch Gear					
Protection device	Diode		varistor		RC module	
Nominal voltage	DC 24–230 V	AC/DC 24 V	AC/DC 60–115 V	AC/DC 230 V	AC 115–230 V	
Shut-off points	≤1 V	≤52 V	≤250 V	≤475 V	–	
Rated frequency	–		50–60 Hz			
Inverse voltage/switching current	1600 V / 1 A 1300 V / 3 A		–			
Holding capacitance	–		200 VA		30 VA	
Type of connecting lead	LIY 0.5 mm <sup>2</sup>					
Length of connecting lead (M)	0.2					
Termination	Fork-type cable lug M4					
<b>General</b>						
Form	V1					
Pottant	2-components					
Housing material	PPO					
Protection class	IP 67					
Field installation	With mounting hole M4, attachable to TS 35 (EN 50022) with 1 snap-on sockets					
Operation temperature range	–20 °C – 60 °C					
Storage temperature range	–40 °C – 90 °C					
Dimensions (w × h × d)	12.5 × 25.0 × 48.0 mm					
Weight (kg/piece)	0.017		0.020		0.031	
Standards	–					
Approvals	cURus					
<b>Accessories</b>						
	<b>Color</b>	<b>Article number</b>	<b>Description</b>	<b>PU</b>		
Snap-on socket type 2	grey	700499	for hat profile TS35 (EN 50022)	10		

# Suppression Technology - Suppressor for Switched Gear

**Universal Suppressor Module**  
**Enclosure type: VM1, V2**  
**Protection device: RC module**



## Dimensions

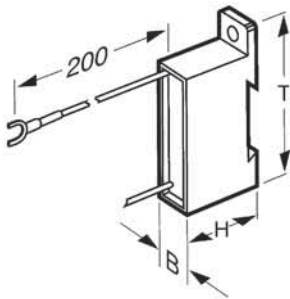

## PIN assignment



Description	Part-No.	Type	PU	
<b>RC module in the V2 enclosure</b>				
Nominal voltage	AC 230–400 V	700464	LRC-V2-0464 AC 400 V 10 VA	10
	AC 230–400 V	701583	LRC-V2-1583 AC 400 V 60 VA	10
<b>RC module in the VM1 enclosure</b>				
Nominal voltage	AC 115–230 V	700463	LRC-VM1-0463 AC 230 V 30 VA	10
<b>Technical data</b>				
	<b>700464</b>	<b>701583</b>	<b>700463</b>	
Function type	Suppressor for Switch Gear			
Protection device	RC module			
Nominal voltage	AC 230–400 V		AC 115–230 V	
Shut-off points	–			
Rated frequency	50–60 Hz			
Inverse voltage/switching current	–			
Holding capacitance	10 VA	60 VA	30 VA	
Type of connecting lead	LIY 0.5 mm <sup>2</sup>			
Length of connecting lead (M)	0.2			
Termination	Fork-type cable lug M4			
<b>General</b>				
Form	V2	VM1		
Pottant	2-components			
Housing material	PPO			
Protection class	IP 67			
Field installation	With mounting hole M4, attachable to TS 35 (EN 50022) with 2 snap-on sockets			
Operation temperature range	-20 °C – 60 °C			
Storage temperature range	-40 °C – 90 °C			
Dimensions (w × h × d)	15.0 × 30.0 × 58.0 mm		15.0 × 41.0 × 48.0 mm	
Weight (kg/piece)	0.028	0.031	0.033	
Standards	–			
Approvals	cURus			
<b>Accessories</b>				
Snap-on socket, hat profile TS35	Color	Article number	Description	PU
	grey	700499	for hat profile TS35 (EN 50022)	10

# Suppression Technology - Suppressor for Switched Gear

Universal suppressor module - for Siemens-, AEG-, EATON contactors  
Enclosure type S6

Protection device: Diode / Varistor / RC module



## Dimensions

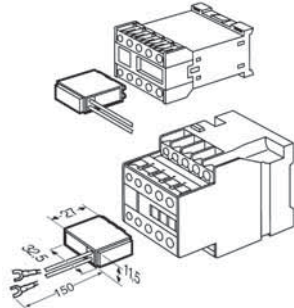

## PIN assignment

700323



700324



700321



Description	Part-No.	Type	PU
<b>Diode</b>			
Nominal voltage	DC 24–230 V	700323	LD-S6-0323 DC 230 V 1 A
<b>varistor</b>			
Nominal voltage	AC/DC 24 V	700324	LV-S6-0324 AC/DC 24 V 200 VA
<b>RC module</b>			
Nominal voltage	AC 115–230 V	700321	LRC-S6-0321 AC 230 V 10 VA
<b>Technical data</b>			
	<b>700323</b>	<b>700324</b>	<b>700321</b>
Function type	Suppressor for Switch Gear		
Protection device	Diode	varistor	RC module
Nominal voltage	DC 24–230 V	AC/DC 24 V	AC 115–230 V
Shut-off points	≤1 V	≤52 V	–
Rated frequency	–	50–60 Hz	
Inverse voltage/switching current	1600 V / 1 A	–	–
Holding capacitance	–	200 VA	10 VA
Type of connecting lead	LIY 0.5 mm <sup>2</sup> , black		
Length of connecting lead (M)	0.15		
Termination	Fork-type cable lug M4		
<b>General</b>			
Form	S6		
Pottant	2-components		
Housing material	PA		
Protection class	IP 67		
Field installation	attachable instead of the identification plate		
Operation temperature range	–20 °C – 60 °C		
Storage temperature range	–40 °C – 90 °C		
Dimensions (w × h × d)	32.5 × 27.0 × 11.5 mm		
Weight (kg/piece)	0.010		
Standards	–		
Approvals	cURus, VDE		

# Suppression Technology - Suppressor for Switched Gear

Universal suppressor module - switch size S00 - for Siemens switches  
 3RT1015-/3RT1016-/3RT1017-/3RH1122-/3RH1131-/3RH1140-  
 Protection device: Diode / Varistor / RC module



Description	Part-No.	Type	PU		
<b>Diode</b>					
Nominal voltage	DC 12–230 V	700952	LD-S11-0952 DC 230 V		
<b>varistor</b>					
Nominal voltage	AC/DC 24 V	700950	LV-S11-0950 AC/DC 24 V		
	AC/DC 115 V	700960	LV-S11-0960 AC/DC 115 V		
	AC/DC 230 V	700951	LV-S11-0951 AC/DC 230 V		
<b>RC module</b>					
Nominal voltage	AC/DC 230 V	700959	LRC-S11-0959 AC/DC 230 V		
<b>Technical data</b>					
	<b>700952</b>	<b>700950</b>	<b>700960</b>	<b>700951</b>	<b>700959</b>
Function type	Suppressor for Switch Gear				
Protection device	Diode		varistor		RC module
Nominal voltage	DC 12–230 V	AC/DC 24 V	AC/DC 115 V		AC/DC 230 V
Shut-off points	≤1 V	≤100 V	≤250 V	≤430 V	≤475 V
Rated frequency	–			50–60 Hz	
Inverse voltage/switching current	4000 V / 0,2 5A				
Holding capacitance				7 VA	
Type of connecting lead					–
Length of connecting lead (M)					–
Termination					Plug contact
<b>General</b>					
Form					S11
Status Indication					–
Housing material					PA
Protection class					IP 20
Field installation					attachable to switches
Operation temperature range					-25 °C – 60 °C
Storage temperature range					-40 °C – 90 °C
Dimensions (w × h × d)					8.5 × 32.0 × 28.0 mm
Weight (kg/piece)					0.005
Standards					–
Approvals					cURus

## Dimensions

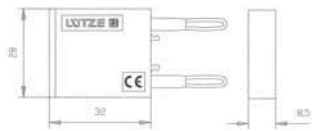

## PIN assignment

700952



700950, 700960, 700951



700959





# Suppression Technology - Suppressor for Switched Gear

Universal suppressor module - switch size S00 - for Siemens switches  
 3RT1015-/3RT1016-/3RT1017-/3RH1122-/3RH1131-/3RH1140-  
 Protection device: Diode + LED / Varistor + LED

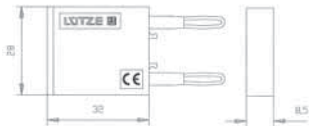

### PIN assignment

#### 700955

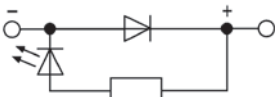

#### 700953, 700954

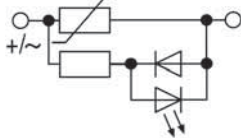

Description	Part-No.	Type	PU
<b>Diode + LED</b>			
Nominal voltage	DC 24 V	700955	LD-S11-0955 DC 24 V
<b>Varistor + LED</b>			
Nominal voltage	AC/DC 24 V	700953	LV-S11-0953 AC/DC 24 V
	AC/DC 230 V	700954	LV-S11-0954 AC/DC 230 V

Technical data	700955	700953	700954
Function type	Suppressor for Switch Gear		
Protection device	Diode + LED	Varistor + LED	
Nominal voltage	DC 24 V	AC/DC 24 V	AC/DC 230 V
Shut-off points	≤1 V	≤100 V	≤475 V
Rated frequency	–	50–60 Hz	
Inverse voltage/switching current	4000 V / 0,25 A	–	
Holding capacitance	–	7 VA	
Type of connecting lead	–		
Length of connecting lead (M)	–		
Termination	Plug contact		
<b>General</b>			
Form	S11		
Status Indication	LED yellow		
Housing material	PA		
Protection class	IP 20		
Field installation	attachable to switches		
Operation temperature range	-25 °C – 60 °C		
Storage temperature range	-40 °C – 90 °C		
Dimensions (w × h × d)	8.5 × 32.0 × 28.0 mm		
Weight (kg/piece)	0.005		
Standards	–		
Approvals	cURus		

### Mounting diagram



# Suppression Technology - Suppressor for Switched Gear

Universal suppressor module for Siemens switches 3RT102 (S0), 3RT103 (S2), 3RT 104 (S3)  
Enclosure type: S12, S13

Protection device: Varistor / RC module



Description	Part-No.	Type	PU	
<b>Varistor, S12</b>				
Nominal voltage	AC/DC 24 V	700956	LV-S12-0956 AC/DC 24 V	10
	AC/DC 115 V	700962	LV-S12-0962 AC/DC 115 V	10
<b>RC module, S12</b>				
Nominal voltage	AC/DC 230 V	700957	LRC-S12-0957 AC/DC 230 V	10
<b>RC module, S13</b>				
Nominal voltage	AC/DC 230 V	700958	LRC-S13-0958 AC/DC 230 V	10

Technical data	700956	700962	700957	700958
Function type	Suppressor for Switch Gear			
Protection device	varistor		RC module, S12	RC module, S13
Nominal voltage	AC/DC 24 V	AC/DC 115 V	AC/DC 230 V	
Shut-off points	≤100 V	≤250 V	≤475 V	
Rated frequency	50–60 Hz			
Inverse voltage/switching current	–			
Holding capacitance	30 VA			
Type of connecting lead	–			
Length of connecting lead (M)	–			
Termination	Plug contact			
<b>General</b>				
Form	S12		S13	
Status Indication	–			
Housing material	PA			
Protection class	IP 20			
Field installation	plug-in			
Operation temperature range	-25 °C – 60 °C			
Storage temperature range	-40 °C – 90 °C			
Dimensions (w × h × d)	32.0 × 25.0 × 10.0 mm		36.0 × 26.5 × 27.0 mm	
Weight (kg/piece)	0.010		0.027	
Standards	–			
Approvals	cURus			

## Dimensions

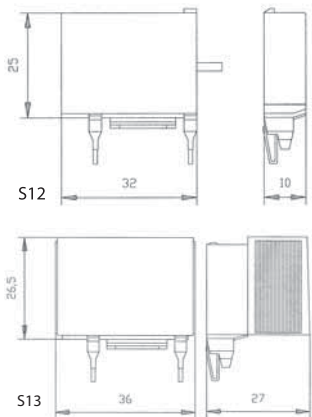

## Mounting diagram



## PIN assignment

700956, 700962



700957, 700958



# Suppression Technology - Suppressors for valves Deutsch DT06-2S

with integrated protection device + LED

2pin version, protected against reverse polarity, moulded PUR connecting cable 2 × 0.75 mm<sup>2</sup> on cable outlet can be directly mounted to a protective hose



### Dimensions

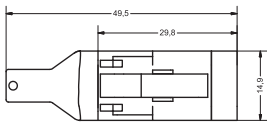
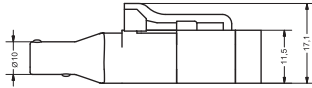

### PIN assignment

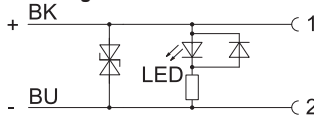

### Pin layout

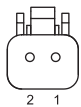

Description	Part-No.	Type	PU	
<b>Suppressor diode + LED</b>				
Length of connecting lead (M)	2.5	709442.0250	LS-DT06 9442.0250 2,5m PUR	10
	5.0	709442.0500	LS-DT06 9442.0500 5,0m PUR	10
	7.5	709442.0750	LS-DT06 9442.0750 7,5m PUR	10
	10.0	709442.1000	LS-DT06 9442.1000 10,0m PUR	10
	15.0	709442.1500	LS-DT06 9442.1500 15,0m PUR	10
	20.0	709442.2000	LS-DT06 9442.2000 20,0m PUR	10

Technical data	.0250	.0500	.0750	.1000	.1500	.2000
Function type	Suppressors for valves					
Protection device	Suppressor diode + LED					
Nominal voltage	DC 12 / 24 V					
Current Consumption per LED	≤10 mA					
Shut-off points	≤52 V					
Rated frequency	-					
Holding capacitance	≤ 100VA					
Type of connecting lead	2 × 0.75 mm <sup>2</sup> PUR black <sup>1)</sup>					
Length of connecting lead (M)	2.5	5	7.5	10	15	20
Connecting lead	∅ 5.0 ± 0.20 mm					

### General

Form	Deutsch DT06-2S					
Status Indication	LED yellow					
Coil Current max.	≤2 A					
Conductor marking	black, blue					
Housing material	PA black, TPU translucent black					
Protection class	IP 67					
Field installation	plug-in Direct assembly with protective conduit is possible.					
Operation temperature range	Male: -30 °C – 85 °C, cable: fixed -40 °C– 80 °C, moving -30 °C – 80 °C					
Storage temperature range	-40 °C – 90 °C					
Dimensions (w × h × d)	14.9 × 17.1 × 49.5 mm					
Weight (kg/piece)	0.13	0.24	0.33	0.46	0.70	0.93
Insulation resistance	>100 MΩ					
Contact material	CuZn nickel-plate					
Test voltage	150 V DC					
Contact resistance	<10 mΩ					
Pol number	2					
Class of flammability according to UL 94	-					
Gasket	Silicon					
Mechanical service life	> 100 plug-in cycles					
Pollution degree	3					
UV stability	-					
Standards	-					
Approvals	-					

Accessories	Color	Article number	Type	PU
Protection tube				
Condufix OL PA 07, NW 10 mm	black	272121	OL PA 10	1
Condufix OS PA 07, NW 10 mm	black	272161	OS PA 10	1

### Comments

<sup>1)</sup> Excellent chemical and oil resistance. The material resistance must be checked based on the application for use with aggressive media!

# Suppression Technology - Suppressors for valves, German DT06-2S - outdoor

with integrated protection device + LED

protection against reverse polarity, moulded single conductor PVC FLRY 2 × 0.75 mm<sup>2</sup>

on cable outlet can be directly mounted to a protective hose



## Dimensions

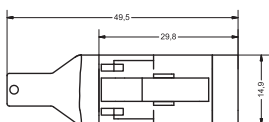
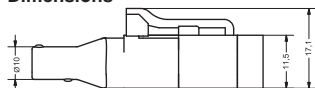

## PIN assignment

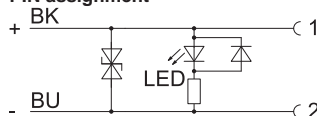

## Pin layout

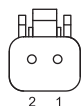

Description	Part-No.	Type	PU	
<b>Suppressor diode + LED</b>				
Length of connecting lead (M)	2.5	709441.0250	LS-DT06 9441 0250 2,5m FLRY	100
	5.0	709441.0500	LS-DT06 9441 0500 5,0m FLRY	100
	7.5	709441.0750	LS-DT06 9441 0750 7,5m FLRY	100
	10.0	709441.1000	LS-DT06 9441 1000 10,0m FLRY	100
	15.0	709441.1500	LS-DT06 9441 1500 15,0m FLRY	100
	20.0	709441.2000	LS-DT06 9441 2000 20,0m FLRY	100

Technical data	.0250	.0500	.0750	.1000	.1500	.2000
Function type	Suppressors for valves					
Protection device	Suppressor diode + LED					
Nominal voltage	AC/DC 18–30 V					
Current Consumption per LED	≤10 mA					
Shut-off points	≤52 V					
Rated frequency	–					
Holding capacitance	≤ 100VA					
Type of connecting lead	2 × single conductors 0.75 mm <sup>2</sup> FLRY black <sup>1)</sup> blue <sup>2)</sup>					
Length of connecting lead (M)	2.5	5	7.5	10	15	20
Connecting lead	∅ 1.8 ± 0.10 mm					

General	
Form	Deutsch DT06-2S
Status Indication	LED yellow
Coil Current max.	≤2 A
Conductor marking	Black, blue with additional printed numbers
Housing material	PA black, TPU translucent black
Protection class	IP 67
Field installation	plug-in Direct assembly with protective conduit is possible.
Operation temperature range	Male: -30 °C – 85 °C Cable: -40 °C – 100 °C (105 °C)
Storage temperature range	-40 °C – 90 °C
Dimensions (w × h × d)	14.9 × 17.1 × 49.5 mm
Weight (kg/piece)	0.09    0.14    0.20    0.25    0.36    0.74
Insulation resistance	>100 MΩ
Contact material	CuZn nickel-plate
Test voltage	150 V DC
Contact resistance	<10 mΩ
Pol number	2
Class of flammability according to UL 94	V0
Gasket	Silicon
Mechanical service life	> 100 plug-in cycles
Pollution degree	3
UV stability	yes
Standards	–
Approvals	–

Accessories	Color	Article number	Type	PU
Protection tube				
Condufix OL PA 07, NW 10 mm	black	272121	OL PA 10	1
Condufix OS PA 07, NW 10 mm	black	272161	OS PA 10	1

## Comments

<sup>1)</sup> Excellent chemical and oil resistance. The material resistance must be checked based on the application for use with aggressive media!

# Suppression Technology - Suppressors for valves AMP Junior Timer

with integrated protection device + LED  
 2-pin style, protection against reverse polarity  
 Moulded PUR connecting cable 2 × 0.75 mm<sup>2</sup>



### Dimensions

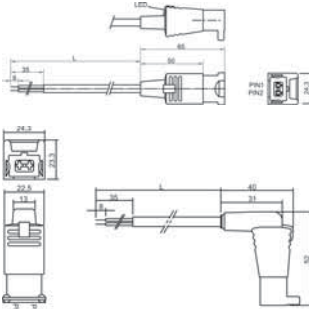

### PIN assignment

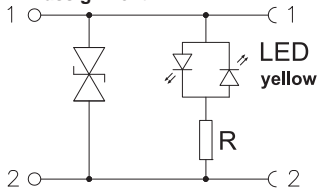

Description	Part-No.	Type	PU	
<b>Suppressor diode + LED straight</b>				
Length of connecting lead (M)	2.5	709482	LS-AMP 9482 2,5m PUR	10
	5.0	709483	LS-AMP 9483 5,0m PUR	10
	7.5	709484	LS-AMP 9484 7,5m PUR	10
	10.0	709485	LS-AMP 9485 10,0m PUR	10
	15.0	709486	LS-AMP 9486 15,0m PUR	10
	20.0	709487	LS-AMP 9487 20,0m PUR	10
<b>Suppressor diode + LED angled</b>				
Length of connecting lead (M)	2.5	709472	LS-AMP 9472 2,5m PUR	10
	5.0	709473	LS-AMP 9473 5,0m PUR	10
	7.5	709474	LS-AMP 9474 7,5m PUR	10
	10.0	709475	LS-AMP 9475 10,0m PUR	10
	15.0	709476	LS-AMP 9476 15,0m PUR	10
	20.0	709477	LS-AMP 9477 20,0m PUR	10

### Technical data

Function type	Suppressors for valves					
Protection device	Suppressor diode + LED					
Nominal voltage	AC/DC 24 V					
Current Consumption per LED	10 mA					
Shut-off points	≥75 V					
Rated frequency	50–60 Hz					
Holding capacitance	≤100 VA					
Type of connecting lead	PUR black/PE 2 × 0.75 mm <sup>2</sup> <sup>1)</sup>					
Length of connecting lead (M)	2.5	5	7.5	10	15	20
Connecting lead	∅ 5.2 ± 0.20 mm					

### General

Form	AMP Junior Timer, 2-pin					
Status Indication	LED yellow					
Coil Current max.	≤4 A					
Conductor marking	black, blue					
Housing material	Polyamid 6.6					
Protection class	IP 65					
Field installation	plug-in					
Operation temperature range	Male: -25 °C – 80 °C, cable: fixed -30 °C– 90 °C, moving -15 °C – 80 °C					
Storage temperature range	-40 °C – 90 °C					
Dimensions (w × h × d)	straight: 24.3 × 22.3 × 65.0			angled: 24.3 × 40.0 × 52.0		
Weight (kg/piece)	0.13	0.24	0.33	0.46	0.70	0.93

### Comments

<sup>1)</sup> Excellent chemical and oil resistance. The material resistance must be checked based on the application for use with aggressive media!

# Suppression Technology - AMP Junior Timer Connector

## 2-pole straight

### Protection device suppressor diode + status indication LED

### with moulded vehicle cable Type FLRY as single conductor 0.75 mm<sup>2</sup>



#### Dimensions

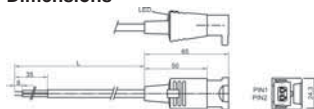

#### PIN assignment

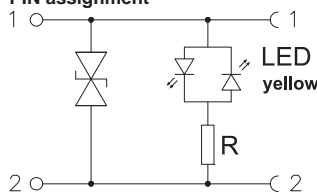

Description	Part-No.	Type	PU	
<b>Suppressor diode + LED</b>				
Length of connecting lead (M)	2.5	709443.0250	LS-AMP 9443 0250 2,5m PVC	100
	5.0	709443.0500	LS-AMP 9443 0500 5,0m PVC	100
	7.5	709443.0750	LS-AMP 9443 0750 7,5m PVC	100
	10.0	709443.1000	LS-AMP 9443 1000 10,0m PVC	100
	15.0	709443.1500	LS-AMP 9443 1500 15,0m PVC	100
	20.0	709443.2000	LS-AMP 9443 2000 20,0m PVC	100

#### Technical data

Function type	Suppressors for valves					
Protection device	Suppressor diode + LED					
Nominal voltage	AC/DC 18–30 V					
Current Consumption per LED	10 mA					
Shut-off points	≥75 V					
Rated frequency	50–60 Hz					
Holding capacitance	≤100 VA					
Type of connecting lead	0.75 mm <sup>2</sup> single conductor FLRY Type B (PVC 105 °C)					
Length of connecting lead (M)	2.5	5	7.5	10	15	20
Connecting lead	∅ 2.1 mm ± 0.20 mm					

#### General

Form	AMP Junior Timer, 2-pin					
Status Indication	LED yellow					
Coil Current max.	≤4 A					
Conductor marking	black, blue					
Housing material	Polyamide 6.6 <sup>1)</sup>					
Protection class	IP 65					
Field installation	plug-in					
Operation temperature range	Male: -30 °C – 80 °C, cable: fixed -40 °C– 105 °C, moving -40 °C – 105 °C					
Storage temperature range	-40 °C – 90 °C					
Dimensions (w × h × d)	24.3 × 22.3 × 65.0					
Weight (kg/piece)	0.09	0.15	0.21	0.27	0.39	0.51
UV stability	yes					

#### Comments

<sup>1)</sup> Excellent chemical and oil resistance. The material resistance must be checked based on the application for use with aggressive media!

# Suppression Technology - Suppressors for valves

## Construction A (18 mm)

2pin version, protected against reverse polarity, moulded PUR connecting cable 2 × 0.75 mm<sup>2</sup>

Protection device: suppressor diode + LED



### Dimensions

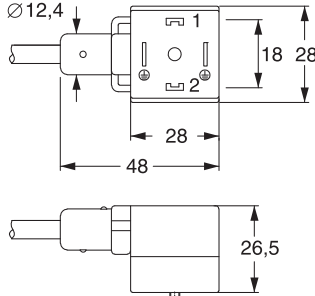

### PIN assignment

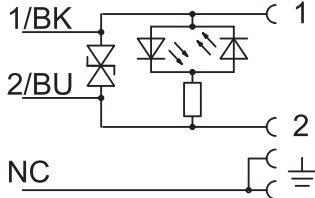

Description	Part-No.	Type	PU	
<b>Suppressor diode + LED</b>				
Length of connecting lead (M)	1.0	709469	LS-A-9469 1,0mPUR AC//DC 24V	10
	2.5	709459	LS-A-9459 2,5mPUR AC//DC 24V	10
	5.0	709460	LS-A-9460 5,0mPUR AC//DC 24V	10
	7.5	709461	LS-A-9461 7,5mPUR AC//DC 24V	10
	10.0	709462	LS-A-9462 10mPUR AC//DC 24V	10

### Technical data

Function type	Suppressors for valves			
Protection device	Suppressor diode + LED			
Nominal voltage	AC/DC 24 V			
Current Consumption per LED	4 mA			
Shut-off points	≤52 V			
Rated frequency	50–60 Hz			
Holding capacitance	<100 VA			
Type of connecting lead	PUR black jacket, PP wire 2 × 0.75 mm <sup>2</sup>			
Length of connecting lead (M)	1	2.5	5	7.5
Connecting lead	Ø 5.0 mm			

### General

Form	Construction A, contact clearance 18 mm			
Status Indication	LED yellow			
Coil Current max.	≤4 A			
Conductor marking	black, blue			
Housing material	TPU transparent <sup>1)</sup>			
Protection class	IP 67			
Field installation	Breakaway torque 0.4 Nm Direct assembly with protective conduit is possible.			

### Termination

Operation temperature range	Male: -25 °C – 90 °C, cable: fixed -30 °C– 90 °C, moving -15 °C – 80 °C			
Storage temperature range	-40 °C – 90 °C			
Dimensions (w × h × d)	28.0 × 26.5 × 48.0 mm			
Weight (kg/piece)	0.08	0.14	0.25	0.36
Standards	EN 175301-803 (DIN 43 650), ISO 4400			

### Approvals

Accessories	Color	Article number	Type	PU
Tag holder 7×20 mm	white	760968	BZT-0720	100
<b>Protective pipes:</b>				
-PA	black	271142	CX 12 PA	50
-PVC with hard PVC coil	grey	270401	CF 12 EL	30
-PVC with steel braiding		270011	CF 13 S	50
-PUR with coil		270411	CF PUR 12 EL	22
Marker sleeve	transparent	499995		500
Plate 4×23mm for 499995		499988		200

### Comments

<sup>1)</sup> Very good chemical and oil resistance. The material resistance must be checked based on the application for use with aggressive media!

# Suppression Technology - Suppressors for valves

## Design A (18 mm), 2-pin without PE

Protection device suppressor diode + LED, with stainless steel screw

Moulded vehicle cable TYPE FLRY as single conductor 2x0.75mm<sup>2</sup>

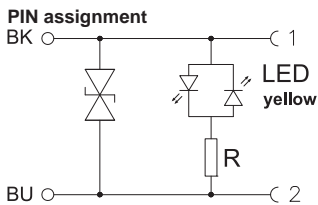
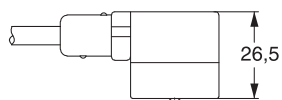
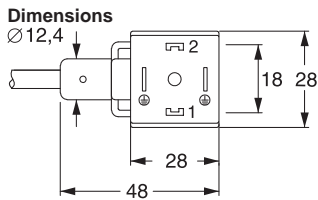

Description	Part-No.	Type	PU	
Length of connecting lead (M)	2.5	709428.0250	LS-A 2,5 m FLRY AC/DC 12-24 V	100
	5.0	709428.0500	LS-A 5,0 m FLRY AC/DC 12-24 V	100
	7.5	709428.0750	LS-A 7,5 m FLRY AC/DC 12-24 V	50
	10.0	709428.1000	LS-A 10,0 m FLRY AC/DC 12-24 V	50
	15.0	709428.1500	LS-A 15,0 m FLRY AC/DC 12-24 V	20
	20.0	709428.2000	LS-A 20,0 m FLRY AC/DC 12-24 V	20

Technical data	
Function type	Suppressors for valves
Protection device	Suppressor diode + LED
Nominal voltage	AC/DC 12-24 V
Current Consumption per LED	-
Shut-off points	-
Rated frequency	50-60 Hz
Holding capacitance	≤100 VA
Type of connecting lead	Single wire FLRY black. blue 0.75 mm <sup>2</sup>
Length of connecting lead (M)	2.5 5 7.5 10 15 20
Connecting lead	∅ 1.8 mm
General	
Form	Construction A, contact clearance 18 mm
Status Indication	-
Coil Current max.	≤7 A
Conductor marking	black, blue
Housing material	TPU translucent black <sup>1)</sup>
Contact material	CuSn, silver-plated
Fixing	Fixing screw stainless steel 1.4567
Protection class	IP 65
Field installation	Breakaway torque 0.4 Nm
Termination	-
Operation temperature range	Plug: -25 °C – 90 °C Cable: -40 °C – 105 °C
Storage temperature range	-40 °C – 90 °C
Dimensions (w × h × d)	28.0 × 26.5 × 48.0 mm
Weight (kg/piece)	0.11 0.17 0.23 0.29 0.41 0.53
Standards	EN 175301-803 (DIN 43 650), ISO 4400
Approvals	-
Comments	
<sup>1)</sup> Excellent chemical and oil resistance. The material resistance must be checked based on the application for use with aggressive media!	



# Suppression Technology - Suppressors for valves

**Design A (18mm), 3-pin without PE, 0°**  
**Without circuit, with stainless steel screw**  
**with moulded vehicle cable Type FLRY as single conductor 3x0.75mm<sup>2</sup>**



## Dimensions

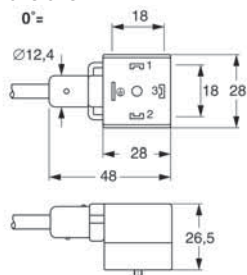

## PIN assignment

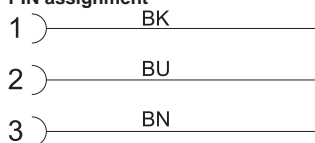

Description	Part-No.	Type	PU	
Length of connecting lead (M)	2.5	709427.0250	L-A 2,5 m FLRY 0° AC/DC 0-230 V	100
	5.0	709427.0500	L-A 5,0 m FLRY 0° AC/DC 0-230 V	100
	7.5	709427.0750	L-A 7,5 m FLRY 0° AC/DC 0-230 V	50
	10.0	709427.1000	L-A 10,0 m FLRY 0° AC/DC 0-230 V	50
	15.0	709427.1500	L-A 15,0 m FLRY 0° AC/DC 0-230 V	20
	20.0	709427.2000	L-A 20,0 m FLRY 0° AC/DC 0-230 V	20

## Technical data

Function type	Suppressors for valves					
Protection device	-					
Nominal voltage	AC/DC 0-230 V					
Current Consumption per LED	-					
Shut-off points	-					
Rated frequency	50-60 Hz					
Holding capacitance	≤100 VA					
Type of connecting lead	Single wire FLRY black, blue, brown 0.75 mm <sup>2</sup>					
Length of connecting lead (M)	2.5	5	7.5	10	15	20
Connecting lead	Ø 1.8 mm					

## General

Form	Design A, contact clearance 18 mm					
Status Indication	-					
Coil Current max.	≤7 A					
Conductor marking	black, blue					
Housing material	TPU black					
Contact material	CuSn, silver-plated					
Fixing	Fixing screw stainless steel 1.4567					
Protection class	IP 65					
Field installation	Breakaway torque 0.4 Nm					
Termination	-					
Operation temperature range	Plug: -25 °C - 90 °C Cable: -40 °C - 105 °C					
Storage temperature range	-40 °C - 90 °C					
Dimensions (w × h × d)	28.0 × 26.5 × 48.0 mm					
Weight (kg/piece)	0.11	0.17	0.23	0.29	0.41	0.53
Standards	EN 175301-803 (DIN 43 650), ISO 4400					
Approvals	-					

## Comments

<sup>1)</sup> Excellent chemical and oil resistance. The material resistance must be checked based on the application for use with aggressive media!

# Suppression Technology - Suppressors for valves

## Construction A (18 mm) PVC connecting lead with bridged ground conductor (PE)

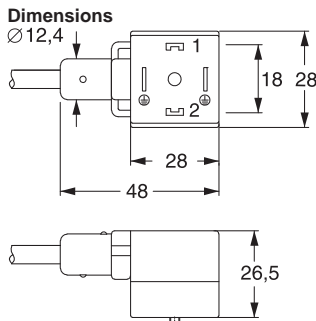

### PIN assignment

709600, 709601, 709608

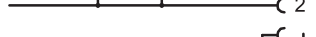
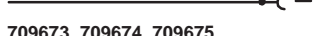
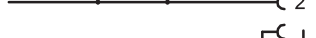
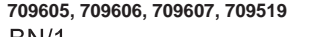

Description	Part-No.	Type	PU	
<b>without component parts</b>				
Nominal voltage	AC/DC 0–230 V	709600	L-A-9600 2,5mPVC up to 230 V	10
	AC/DC 0–230 V	709601	L-A-9601 5mPVC up to 230 V	10
	AC/DC 0–230 V	709608	L-A-9608 10,0m PVC 0-230 V	10
<b>Suppressor diode</b>				
Nominal voltage	AC/DC 24 V	709605	LS-A-9605 2,5m PVC 24 V	10
	AC/DC 24 V	709606	LS-A-9606 5,0m PVC 24 V	10
	AC/DC 24 V	709607	LS-A-9607 10,0m PVC 24 V	10
	AC/DC 24 V	709519	LS-A-9519 15,0m PVC 24 V	10
<b>varistor</b>				
Nominal voltage	AC/DC 230 V	709673	LV-A-9673 2,5m PVC 230 V	10
	AC/DC 230 V	709674	LV-A-9674 5,0m PVC 230 V	10
	AC/DC 230 V	709675	LV-A-9675 10,0m PVC 230 V	10

Technical data	without component parts	Suppressor diode	varistor
Function type	Suppressors for valves		
Protection device	–	Suppressor diode	varistor
Nominal voltage	AC/DC 0–230 V	AC/DC 24 V	AC/DC 230 V
Current Consumption per LED	–	4 mA	3 mA
Shut-off points	–	≤52 V	≤475 V
Rated frequency	50–60 Hz		
Holding capacitance	–	≤ 100VA	
Type of connecting lead	PVC black / PVC 3 × 0.5 mm <sup>2</sup>		
Length of connecting lead (M)	2.5 5 10	2.5 5 10 15	2.5 5 10
Connecting lead	∅ 4.8 ± 0.15 mm		

### General

Form	Construction A, contact clearance 18 mm		
Status Indication	–	LED yellow	
Coil Current max.	≤7 A	≤4 A	≤0.5 A
Conductor marking	color-coded conductors		
Housing material	TPU black <sup>1)</sup>	TPU transparent <sup>1)</sup>	
Protection class	IP 67		
Field installation	Breakaway torque 0.4 Nm Direct assembly with protective conduit is possible.		

Termination	–		
Operation temperature range	Male: -25°C – 90°C, cable: fixed -30°C– 80°C, moving -5°C – 70°C		
Storage temperature range	-40 °C – 90 °C		
Dimensions (w × h × d)	28.0 × 26.5 × 48.0 mm		
Weight (kg/piece)	0.13	0.22	0.53
Standards	EN 175301-803 (DIN 43 650), ISO 4400		
Approvals	–		

Accessories	Color	Article number	Type	PU
Tag holder 7×20 mm	white	760968	BZT-0720	100
<b>Protective pipes:</b>				
-PA	black	271142	CX 12 PA	50
-PVC with hard PVC coil	grey	270401	CF 12 EL	30
-PVC with steel braiding		270011	CF 13 S	50
-PUR with coil		270411	CF PUR 12 EL	22
Marker sleeve	transparent	499995		500
Tag holder 4×23 mm for 499995		499988		200

### Comments

<sup>1)</sup> Very good chemical and oil resistance. The material resistance must be checked based on the application for use with aggressive media!

# Suppression Technology - Suppressors for valves

## Construction A (18 mm) PUR connecting lead with bridged ground conductor (PE)

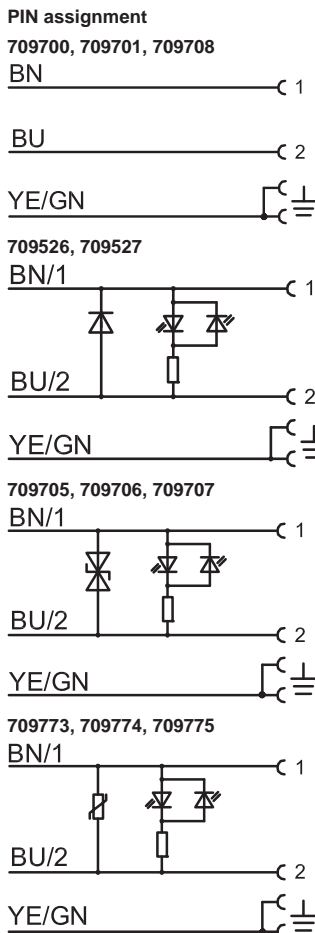
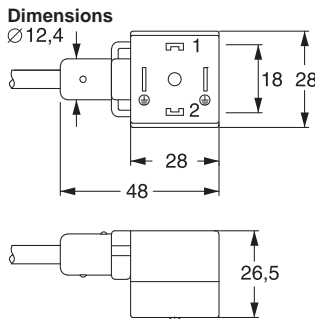

Description	Part-No.	Type	PU	
<b>without component parts</b>				
Nominal voltage	AC/DC 0–230 V	709700	L-A-9700 2,5mPUR up to 230 V	10
	AC/DC 0–230 V	709701	L-A-9701 5mPUR up to 230 V	10
	AC/DC 0–230 V	709708	L-A-9708 10,0m PUR 0-230 V	10
<b>Diode</b>				
Nominal voltage	DC 24 V	709526	LD-A-9526 2,0m PUR 24 V	10
	DC 24 V	709527	LD-A-9527 5,0m PUR 24 V	10
<b>Suppressor diode</b>				
Nominal voltage	AC/DC 24 V	709705	LS-A-9705 2,5m PUR 24 V	10
	AC/DC 24 V	709706	LS-A-9706 5,0m PUR 24 V	10
	AC/DC 24 V	709707	LS-A-9707 10,0m PUR 24 V	10
<b>varistor</b>				
Nominal voltage	AC/DC 230 V	709773	LV-A-9773 2,5m PUR 230 V	10
	AC/DC 230 V	709774	LV-A-9774 5,0m PUR 230 V	10
	AC/DC 230 V	709775	LV-A-9775 10,0m PUR 230 V	10

Technical data	without component parts	Diode	Suppressor diode	varistor
Function type	Suppressors for valves			
Protection device	–	Diode + LED	Suppressor diode + LED	Varistor + LED
Nominal voltage	AC/DC 0–230 V	DC 24 V	AC/DC 24 V	AC/DC 230 V
Current Consumption per LED	–	–	4 mA	3 mA
Shut-off points	–	≤1 V	≤52 V	≤475 V
Rated frequency	50–60 Hz	–	–	50–60 Hz
Holding capacitance	–	–	–	≤ 100VA
Type of connecting lead	PUR black/PVC 3 × 0.5 mm <sup>2</sup>			
Length of connecting lead (M)	2.5 5 10	2.5 5	2.5 5 10	2.5 5 10
Connecting lead	∅ 5.0 ± 0.15 mm			
<b>General</b>				
Form	Construction A, contact clearance 18 mm			
Status Indication	–			LED yellow
Coil Current max.	≤7 A	≤4 A		≤0.5 A
Conductor marking	color-coded conductors			
Housing material	TPU black <sup>1)</sup>		TPU transparent <sup>1)</sup>	
Protection class	IP 67			
Field installation	Breakaway torque 0.4 Nm Direct assembly with protective conduit is possible.			
Termination	–			
Operation temperature range	Male: -25 °C – 90 °C, cable: fixed -40 °C– 80 °C, moving -20 °C – 80 °C			
Storage temperature range	-40 °C – 90 °C			
Dimensions (w × h × d)	28.0 × 26.5 × 48.0 mm			
Weight (kg/piece)	0.13	0.23	0.53	0.13 0.23 0.13 0.23 0.53 0.13 0.23 0.53
Standards	EN 175301-803 (DIN 43 650), ISO 4400			

Accessories	Color	Article number	Type	PU
Plate 7×20mm	white	760968	BZT-0720	100
<b>Protective pipes:</b>				
-PA	black	271142	CX 12 PA	50
-PVC with hard PVC coil	grey	270401	CF 12 EL	30
-PVC with steel braiding		270011	CF 13 S	50
-PUR with coil		270411	CF PUR 12 EL	22
Marker sleeve	transparent	499995		500
Plate 4×23mm for 499995		499988		200

**Comments**  
<sup>1)</sup> Very good chemical and oil resistance. The material resistance must be checked based on the application for use with aggressive media!

# Suppression Technology - Valve Suppressors - special function

## Energy reducer, construction A (18 mm), PUR cable

Energy reduction approx. 50 %, protection device, LED status indication

0° – 180° field installation, open cable end



### Dimensions

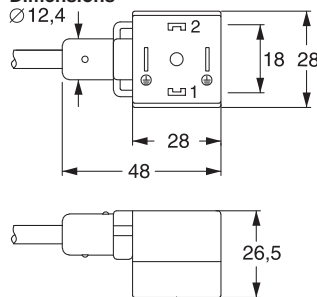

### PIN assignment

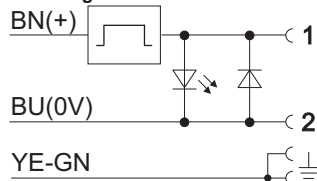

Description	Part-No.	Type	PU
<b>Energy reducer</b>			
Length of connecting lead (M)	2.5	709709.0250	LER-A-9709 2,5m PUR DC 24 V
	5.0	709709.0500	LER-A-9709 5,0m PUR DC 24 V
	10.0	709709.1000	LER-A-9709 10,0m PUR DC 24 V

### Technical data

Function type	Energy reducer		
Protection device	Free-wheeling diode		
Nominal voltage	DC 24 V		
Current Consumption per LED	24 mA		
Shut-off points	≤1 V		
Switching frequency	max. 2 Hz		
Holding capacitance	Reduction factor approx. 50 %		
Type of connecting lead	PUR black 3 × 0.5 mm <sup>2</sup>		
Length of connecting lead (M)	2.5	5	10
Connecting lead	∅ 5.0 ± 0.15 mm		

### General

Form	Construction A, contact clearance 18 mm		
Status Indication	LED yellow		
Amperage range	≤2 A		
Conductor insulation	PVC		
Coil Current max.	-		
Conductor marking	-		
Housing material	TPU transparent <sup>1)</sup>		
Protection class	IP 67		
Field installation	Breakaway torque 0.4 Nm		

Operation temperature range	Male: -25 °C – 60 °C, cable: fixed -40 °C– 80 °C, moving -20 °C – 80 °C		
Storage temperature range	-40 °C – 90 °C		
Dimensions (w × h × d)	22.0 × 26.5 × 50.0 mm		
Weight (kg/piece)	0.13	0.23	0.53
Standards	EN 175301-803 (DIN 43 650), ISO 4400		

Accessories	Color	Article number	Type	PU
Tag holder 7×20 mm	white	760968	BZT-0720	100
<b>Protective pipes:</b>				
-PA	black	271142	CX 12 PA	50
-PVC with hard PVC coil	grey	270401	CF 12 EL	30
-PVC with steel braid		270011	CF 13 S	50
PUR with coil		270411	CF PUR 12 EL	22
Designation sleeve	transparent	499995		500
Tag holder 4×23 mm for 499995		499988		200

### Comments

<sup>1)</sup> Excellent chemical and oil resistance. The material resistance must be checked based on the application for use with aggressive media!

# Suppression Technology - Valve Suppressors - special function

## Construction A (18 mm) PUR connecting lead Pressure switch / fill level monitor



### Dimensions

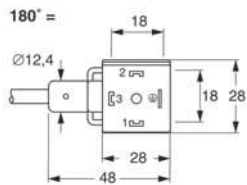
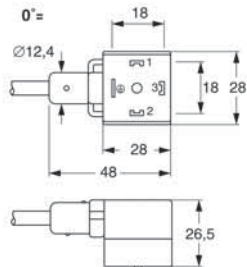

### PIN assignment

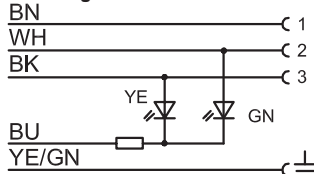

Description	Part-No.	Type	PU	
<b>0°; PE at the cable entry point</b>				
Nominal voltage	DC 24 V	709772	LDS-A-9772 5,0m PUR DC 24 V	10
	DC 24 V	709771	LDS-A-9771 10,0m PUR DC 24 V	10
<b>180°; PE across from the cable entry point</b>				
Nominal voltage	DC 24 V	709782	LDS-A-9782 5,0m PUR DC 24 V	10
	DC 24 V	709789	LDS-A-9789 10,0m PUR DC 24 V	10
<b>Technical data</b>				
	<b>709772</b>	<b>709771</b>	<b>709782</b>	<b>709789</b>
Function type	Pressure switch / fill level monitor			
Protection device	-			
Nominal voltage	DC 24 V			
Nominal voltage range	30 V			
Current Consumption per LED	4 mA			
Power	-			
Rise time	-			
Saturated voltage at max. current	-			
Switching thresholds	-			
Accuracy	-			
Control current	-			
Switching current	≤ 4 A			
Switching frequency	-			
Switch-on delay	-			
Switch-off delay	-			
Shut-off points	-			
Rated frequency	-			
Holding capacitance	-			
Type of connecting lead	PUR black/PVC 3 × 0.5 mm <sup>2</sup>			
Length of connecting lead (M)	5	10	5	10
Connecting lead	Ø 5.6 + 0.15 mm			
Fittings	-			
Short-circuit protection	-			
<b>General</b>				
Form	Construction A, contact clearance 18 mm			
Status Indication	LED yellow + LED green			
Galvanic insulation I/O	-			
Clearance/creep. dist. (control/load side)	-			
Derating	-			
Conductor marking	color-coded conductors			
Housing material	TPU transparent <sup>1)</sup>			
Protection class	IP 67			
Field installation	Breakaway torque 0.4 Nm Direct assembly with protective conduit is possible.			
Operation temperature range	Male: -25 °C – 90 °C, cable: fixed -40 °C – 80 °C, moving -20 °C – 80 °C			
Storage temperature range	-40 °C – 90 °C			
Dimensions (w × h × d)	28.0 × 26.5 × 48.0 mm			
Weight (kg/piece)	0.225	0.530	0.225	0.530
Standards	EN 175301-803 (DIN 43 650), ISO 4400			
Termination	-			
Approvals	-			
<b>Accessories</b>				
Tag holder 7×20 mm	Color	Article number	Type	PU
	white	760968	BZT-0720	100
Protective pipes:				
-PA	black	271142	CX 12 PA	50
-PVC with hard PVC coil	grey	270401	CF 12 EL	30
-PVC with steel braid		270011	CF 13 S	50
-PUR with Conduflex coil		270411	CF PUR 12 EL	22
Designation sleeve	transparent	499995		500
Tag holder 4×23 mm for 499995		499988		200

### Comments

<sup>1)</sup> Excellent chemical and oil resistance. The material resistance must be checked based on the application for use with aggressive media!

# Suppression Technology - Valve Suppressors - special function

## Construction A (18 mm)

### PUR connecting lead

### Switching amplifier, short-circuit-proof, 0°–180° installation



#### Dimensions

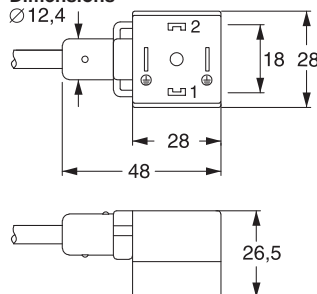

#### PIN assignment

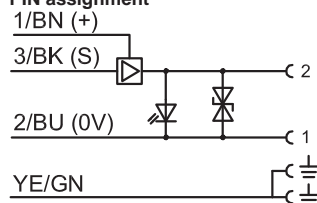

Description	Part-No.	Type	PU	
<b>without galvanic insulation</b>				
Nominal voltage	DC 24 V	709790	LVER-A-9790 2,5m PUR DC 24 V	10
	DC 24 V	709791	LVER-A-9791 5,0m PUR DC 24 V	10
	DC 24 V	709792	LVER-A-9792 10,0m PUR DC 24 V	10
	DC 24 V	709794	LVER-A-9794 20,0m PUR DC 24 V	10

Technical data	709790	709791	709792	709794
Function type	Switching amplifier			
Protection device	Suppressor diode			
Nominal voltage	DC 24 V			
Nominal voltage range	19.2 – 30 V			
Current Consumption per LED	2.4 mA			
Power	–			
Rise time	–			
Saturated voltage at max. current	–			
Switching thresholds	–			
Accuracy	–			
Control current	–			
Switching current	0.005A – 2A, short circuit protection			
Switching frequency	max. 20 Hz			
Switch-on delay	<100 µs			
Switch-off delay	<200 µs			
Shut-off points	≤52 V			
Rated frequency	–			
Holding capacitance	100 VA			
Type of connecting lead	PUR black / PVC 4 x 0.75 mm <sup>2</sup>			
Length of connecting lead (M)	2.5	5	10	20
Connecting lead	∅ 5.8 ± 0.15 mm			
Fittings	–			
Short-circuit protection	yes			
<b>General</b>				
Form	Construction A, contact clearance 18 mm			
Status Indication	LED yellow			
Galvanic insulation I/O	–			
Clearance/creep. dist. (control/load side)	–			
Derating	–			
Conductor marking	color-coded conductors			
Housing material	TPU transparent <sup>1)</sup>			
Protection class	IP 67			
Field installation	Breakaway torque 0.4 Nm Direct assembly with protective conduit is possible.			
Operation temperature range	Male: -25 °C – 90 °C, cable: fixed -40 °C – 80 °C, moving -20 °C – 80 °C			
Storage temperature range	-40 °C – 80 °C			
Dimensions (w × h × d)	28.0 × 26.5 × 48.0 mm			
Weight (kg/piece)	0.140	0.300	0.560	1.000
Standards	EN 175301-803 (DIN 43 650), ISO 4400			
Termination	–			
Approvals	–			
<b>Accessories</b>				
Tag holder 7×20 mm	Color	Article number	Type	PU
	white	760968	BZT-0720	100
Protective pipes:				
-PA	black	271142	CX 12 PA	50
-PVC with hard PVC coil	grey	270401	CF 12 EL	30
-PVC with steel braid		270011	CF 13 S	50
-PUR with Conduflex coil		270411	CF PUR 12 EL	22
Designation sleeve	transparent	499995		500
Tag holder 4×23 mm for 499995		499988		200

#### Comments

<sup>1)</sup> Excellent chemical and oil resistance. The material resistance must be checked based on the application for use with aggressive media.

# Suppression Technology - Suppressors for valves

## Construction B (10 mm)

PUR/PVC cable

Protection device: suppressor diode + LED



### Dimensions

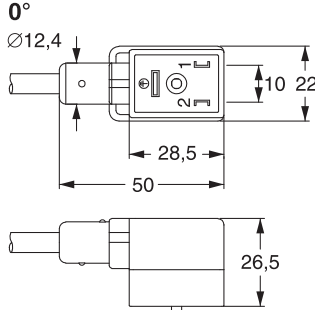

### 180°

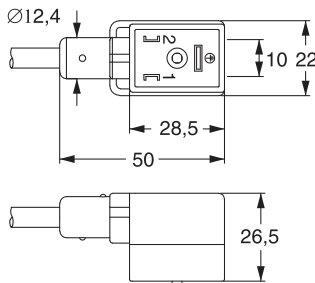

### PIN assignment

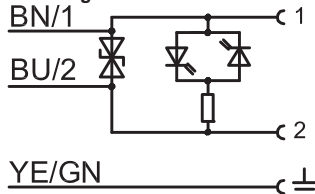

Description	Part-No.	Type	PU
<b>Cable outlet 0°, PVC</b>			
Length of connecting lead (M)	2.5	709615	LS-B-9615 2,5m PVC 0° 24 V
	5.0	709616	LS-B-9616 5,0m PVC 0° 24 V
	10.0	709617	LS-B-9617 10,0m PVC 0° 24 V
<b>Cable outlet 180°, PVC</b>			
Length of connecting lead (M)	2.5	709625	LS-B-9625 2,5m PVC 180° 24 V
	5.0	709626	LS-B-9626 5,0m PVC 180° 24 V
	10.0	709627	LS-B-9627 10,0m PVC 180° 24 V
<b>Cable outlet 0°, PUR</b>			
Length of connecting lead (M)	2.5	709715	LS-B-9715 2,5m PUR 0° 24 V
	5.0	709716	LS-B-9716 5,0m PUR 0° 24 V
	10.0	709717	LS-B-9717 10,0m PUR 0° 24 V
<b>Cable outlet 180°, PUR</b>			
Length of connecting lead (M)	2.5	709725	LS-B-9725 2,5m PUR 180° 24 V
	5.0	709726	LS-B-9726 5,0m PUR 180° 24 V
	10.0	709727	LS-B-9727 10,0m PUR 180° 24 V

Technical data	PVC connecting lead	PUR connecting lead
Function type	Suppressors for valves	
Protection device	Suppressor diode	
Nominal voltage	AC/DC 24 V	
Current Consumption per LED	4 mA	
Shut-off points	≤52 V	
Rated frequency	50–60 Hz	
Holding capacitance	≤ 100VA	
Type of connecting lead	PVC black / PVC 3 × 0.5 mm <sup>2</sup>	PUR black/PUR 3 × 0.5 mm <sup>2</sup>
Length of connecting lead (M)	2.5 5 10	2.5 5 10
Connecting lead	Ø 4.8 ± 0.5 mm Ø 5.0 ± 0.5 mm	

General	
Form	Construction B, contact clearance 10 mm
Status Indication	LED yellow
Coil Current max.	≤4 A
Conductor marking	color-coded conductors
Housing material	TPU transparent <sup>1)</sup>
Protection class	IP 67
Field installation	Breakaway torque 0.4 Nm Direct assembly with protective conduit is possible.
Termination	–
Operation temperature range	Male: -25°C – 90°C, cable: fixed -30°C – 80°C, moving -5°C – 70°C      Male: -25 °C – 90 °C, cable: fixed -40 °C – 80 °C, moving -20 °C – 80 °C
Storage temperature range	-40 °C – 90 °C
Dimensions (w × h × d)	22.0 × 26.5 × 50.0 mm
Weight (kg/piece)	0.13    0.22    0.53    0.13    0.22    0.53
Standards	EN 175301-803 (DIN 43 650), ISO 6952

Approvals				
Accessories				
Plate 4×11mm	Color	Article number	Type	PU
Plate 4×11mm	white	681313	BZT-0411	100
Protective pipes:				
-PA	black	271142	CX 12 PA	50
-PVC with hard PVC coil	grey	270401	CF 12 EL	30
-PVC with steel braid		270011	CF 13 S	50
PUR with coil		270411	CF PUR 12 EL	22
Designation sleeve	transparent	499995		500
Plate 4×23mm for 499995		499988		200

**Comments**  
<sup>1)</sup> Excellent chemical and oil resistance. The material resistance must be checked based on the application for use with aggressive media!

# Suppression Technology - Suppressors for valves

## Construction BI (11 mm)

PUR/PVC cable

Protection device: suppressor diode + LED



### Dimensions

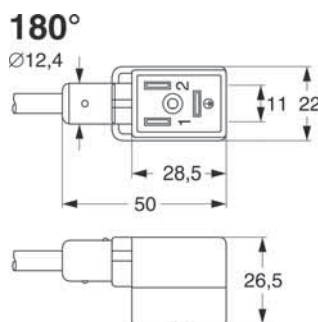
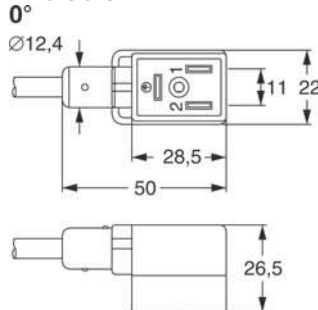

### PIN assignment

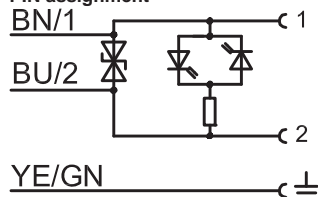

Description	Part-No.	Type	PU	
<b>Cable outlet 0°, PVC</b>				
Length of connecting lead (M)	2.5	709635	LS-BI-9635 2,5m PVC 0° 24 V	10
	5.0	709636	LS-BI-9636 5,0m PVC 0° 24 V	10
	10.0	709637	LS-BI-9637 10,0m PVC 0° 24 V	10
<b>Cable outlet 180°, PVC</b>				
Length of connecting lead (M)	2.5	709645	LS-BI-9645 2,5m PVC 180° 24 V	10
	5.0	709646	LS-BI-9646 5,0m PVC 180° 24 V	10
	10.0	709647	LS-BI-9647 10,0m PVC 180° 24 V	10
<b>Cable outlet 0°, PUR</b>				
Length of connecting lead (M)	2.5	709735	LS-BI-9735 2,5m PUR 0° 24 V	10
	5.0	709736	LS-BI-9736 5,0m PUR 0° 24 V	10
	10.0	709737	LS-BI-9737 10,0m PUR 0° 24 V	10
<b>Cable outlet 180°, PUR</b>				
Length of connecting lead (M)	2.5	709745	LS-BI-9745 2,5m PUR 180° 24 V	10
	5.0	709746	LS-BI-9746 5,0m PUR 180° 24 V	10
	10.0	709747	LS-BI-9747 10,0m PUR 180° 24 V	10

Technical data	PVC connecting lead	PUR connecting lead		
Function type	Suppressors for valves			
Protection device	Suppressor diode			
Nominal voltage	AC/DC 24 V			
Current Consumption per LED	4 mA			
Shut-off points	≤52 V	≥52 V		
Rated frequency	50–60 Hz			
Holding capacitance	≤ 100VA			
Type of connecting lead	PVC black / PVC 3 × 0.5 mm <sup>2</sup>	PUR black/PVC 3 × 0.5 mm <sup>2</sup>		
Length of connecting lead (M)	2.5 5 10	2.5 5 10		
Connecting lead	∅ 4.8 ± 0.15 mm	∅ 5.0 ± 0.15 mm		
<b>General</b>				
Form	Construction B, contact clearance 11 mm (Industry)			
Status Indication	LED yellow			
Coil Current max.	≤4 A			
Conductor marking	color-coded conductors			
Housing material	TPU transparent <sup>1)</sup>			
Protection class	IP 67			
Field installation	Breakaway torque 0.4 Nm Direct assembly with protective conduit is possible.			
Termination	-			
Operation temperature range	Male: -25°C – 90°C, cable: fixed -30°C – 80°C, moving -5°C – 70°C	Male: -25 °C – 90 °C, cable: fixed -40 °C – 80 °C, moving -20 °C – 80 °C		
Storage temperature range	-40 °C – 90 °C			
Dimensions (w × h × d)	22.0 × 26.5 × 50.0 mm			
Weight (kg/piece)	0.13 0.22 0.53	0.13 0.22 0.53		
Standards	-			
Approvals	-			
<b>Accessories</b>				
Plate 4×11mm	white	681313	BZT-0411	100
Protective pipes:				
-PA	black	271142	CX 12 PA	50
-PVC with hard PVC coil	grey	270401	CF 12 EL	30
-PVC with steel braid		270011	CF 13 S	50
PUR with coil		270411	CF PUR 12 EL	22
Designation sleeve	transparent	499995		500
Plate 4×23mm for 499995		499988		200

**Comments**  
<sup>1)</sup> Excellent chemical and oil resistance. The material resistance must be checked based on the application for use with aggressive media!



# Suppression Technology - Suppressors for valves

## Construction C (8 mm)

PUR/PVC cable

with bridged ground conductor (PE)



### Dimensions

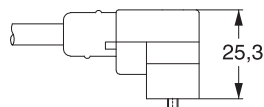
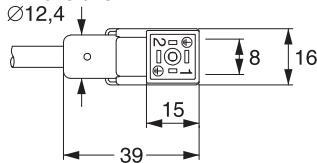

### PIN assignment

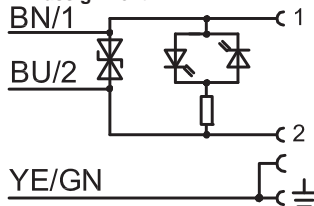

Description	Part-No.	Type	PU	
<b>PVC connecting lead</b>				
Length of connecting lead (M)	2.5	709653	LS-C-9653 2,5m PVC 24V	10
	5.0	709654	LS-C-9654 5,0m PVC 24V	10
	10.0	709659	LS-C-9659 10,0m PVC 24V	10
<b>PUR connecting lead</b>				
Length of connecting lead (M)	2.5	709753	LS-C-9753 2,5m PUR 24 V	10
	5.0	709754	LS-C-9754 5,0m PUR 24 V	10
	10.0	709759	LS-C-9759 10,0m PUR 24 V	10

Technical data	PVC connecting lead	PUR connecting lead
Function type	Suppressors for valves	
Protection device	Suppressor diode	
Nominal voltage	AC/DC 24 V	
Current Consumption per LED	4 mA	
Shut-off points	≤52 V	
Rated frequency	50–60 Hz	
Holding capacitance	≤ 70VA	70 VA
Type of connecting lead	PVC black / PVC 3 × 0.5 mm <sup>2</sup>	PUR black/PVC 3 × 0.5 mm <sup>2</sup>
Length of connecting lead (M)	2.5 5 10	2.5 5 10
Connecting lead	∅ 4.8 ± 0.15 mm	∅ 5.0 ± 0.15 mm

General	
Form	Construction C, contact clearance 8 mm
Status Indication	LED yellow
Coil Current max.	≤3 A
Conductor marking	color-coded conductors
Housing material	TPU transparent <sup>1)</sup>
Protection class	IP 67
Field installation	Breakaway torque 0.4 Nm Direct assembly with protective conduit is possible.

Termination	-		
Operation temperature range	Male: -25°C – 90°C, cable: fixed -30°C– 80°C, moving -5°C – 70°C	Male: -25 °C – 90 °C, cable: fixed -40 °C– 80 °C, moving -20 °C – 80 °C	
Storage temperature range	-40 °C – 90 °C		
Dimensions (w × h × d)	16.0 × 25.3 × 39.0 mm		
Weight (kg/piece)	0.12	0.22	0.52
Standards	EN 175301-803 (DIN 43 650) ISO 6952		

Approvals				
-				
Accessories	Color	Article number	Type	PU
Plate 4×11mm	white	681313	BZT-0411	100
Protective pipes:				
-PA	black	271142	CX 12 PA	50
-PVC with hard PVC coil	grey	270401	CF 12 EL	30
-PVC with steel braid		270011	CF 13 S	50
PUR with coil		270411	CF PUR 12 EL	22
Designation sleeve	transparent	499995		500
Plate 4×23mm for 499995		499988		200

**Comments**  
<sup>1)</sup> Excellent chemical and oil resistance. The material resistance must be checked based on the application for use with aggressive media!

# Suppression Technology - Suppressors for valves

## Construction CI (9.4 mm) PUR/PVC cable with bridged ground conductor (PE)

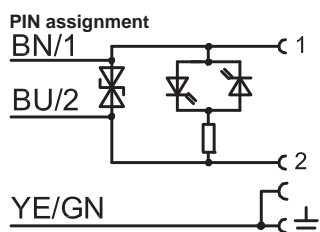
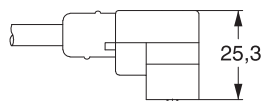
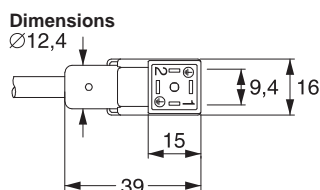

Description	Part-No.	Type	PU	
<b>PVC connecting lead</b>				
Length of connecting lead (M)	2.5	709666	LS-CI-9666 2,5m PVC 24 V	10
	5.0	709667	LS-CI-9667 5,0m PVC 24 V	10
	10.0	709668	LS-CI-9668 10,0m PVC 24 V	10
<b>PUR connecting lead</b>				
Length of connecting lead (M)	2.5	709766	LV-CI-9766 2,5m PUR 24 V	10
	5.0	709767	LV-CI-9767 5,0m PUR 24 V	10
	10.0	709768	LV-CI-9768 10,0m PUR 24 V	10

Technical data	PVC connecting lead	PUR connecting lead
Function type	Suppressors for valves	
Protection device	Suppressor diode	
Nominal voltage	AC/DC 24 V	
Current Consumption per LED	4 mA	
Shut-off points	≤52 V	
Rated frequency	50–60 Hz	
Holding capacitance	≤ 70VA	
Type of connecting lead	PVC black / PVC 3 × 0.5 mm <sup>2</sup>	PUR black/PVC 3 × 0.5 mm <sup>2</sup>
Length of connecting lead (M)	2.5 5 10	2.5 5 10
Connecting lead	Ø 4.8 ± 0.15 mm	Ø 5.0 ± 0.15 mm

General	
Form	Construction CI, contact clearance 9.4 mm (industry)
Status Indication	LED yellow
Coil Current max.	≤3 A
Conductor marking	color-coded conductors
Housing material	TPU transparent <sup>1)</sup>
Protection class	IP 67
Field installation	Breakaway torque 0.4 Nm Direct assembly with protective conduit is possible.

Termination	-	
Operation temperature range	Male: -25°C – 90°C, cable: fixed -30°C – 80°C, moving -5°C – 70°C	Male: -25 °C – 90 °C, cable: fixed -40 °C – 80 °C, moving -20 °C – 80 °C

Storage temperature range	-40 °C – 90 °C	
Dimensions (w × h × d)	16.0 × 25.3 × 39.0 mm	
Weight (kg/piece)	0.12 0.22 0.52	0.12 0.22 0.52
Standards	-	
Approvals	-	

Accessories	Color	Article number	Type	PU
Plate 4×11mm	white	681313	BZT-0411	100
Protective pipes:				
-PA	black	271142	CX 12 PA	50
-PVC with hard PVC coil	grey	270401	CF 12 EL	30
-PVC with steel braid		270011	CF 13 S	50
PUR with coil		270411	CF PUR 12 EL	22
Designation sleeve	transparent	499995		500
Plate 4×23mm for 499995		499988		200

**Comments**  
<sup>1)</sup> Excellent chemical and oil resistance. The material resistance must be checked based on the application for use with aggressive media!

# Suppression Technology - Suppressors for valves

Adjustable male, design A (18 mm)

Ground wire terminator (PE) adjustable in 90° steps by turning the coding disk

Protection device: without circuit / Z-Diode+LED / Varistor+LED



### Dimensions

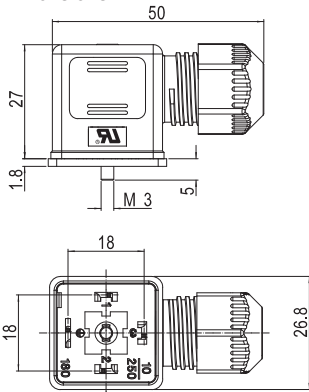

### PIN assignment

#### 705800

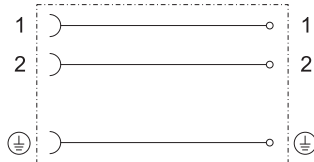

#### 705801

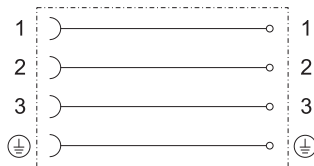

#### 705810

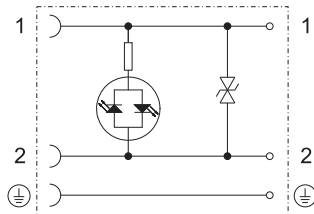

#### 705830

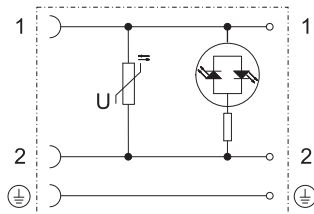

Description	Part-No.	Type	PU	
<b>without circuit</b>				
Nominal voltage	AC/DC 0–230 V	705800	L-V20-5800 AC/DC 0-230 V	1
	AC/DC 0–230 V	705801	L-V20-5801 AC/DC 0-230 V	1
<b>Z-diode + LED</b>				
Nominal voltage	AC/DC 24 V	705810	LS-V20-5810 AC/DC 24 V	1
<b>Varistor + LED</b>				
Nominal voltage	AC/DC 110–230 V	705830	LV-V20-5830 AC/DC 110-230 V	1

Technical data	705800	705801	705810	705830
Function type	Suppressors for valves			
Pol number	2-pole + PE	3-pole + PE	2-pole + PE	
Protection device	without circuit		Z-diode + LED	Varistor + LED
Nominal voltage	AC/DC 0–230 V		AC/DC 24 V	AC/DC 110–230 V
Current Consumption per LED	–			
Shut-off points	–			
Rated frequency	50–60 Hz			
Holding capacitance	–			
Type of connecting lead	–			
Length of connecting lead (M)	–			
Connecting lead	Ø 4 – 9 mm			
<b>General</b>				
Form	Construction A, contact clearance 18 mm			
Status Indication	LED yellow			
Switching current	10 A		4 A	1 A
Coil Current max.	–			
Conductor marking	–			
Housing material	PA black UL94-V0		PA transparent UL94-HB	
Protection class	IP 67			
Field installation	Breakaway torque 0.4 Nm			
Termination	Screw terminal max. 16 AWG / 1.5 mm <sup>2</sup>			
Seal	NBR black			
Operation temperature range	–40 °C – 90 °C			
Dimensions (w × h × d)	26.8 × 28.8 × 50.0 mm			
Weight (kg/piece)	0.02			
Standards	EN 175301-803 (DIN 43 650)			
Approvals	UL recognized			

# Suppression Technology - Suppressors for valves

## Adjustable plug Construction A (18 mm) Ground wire terminator (PE) adjustable in 180° steps



### Dimensions

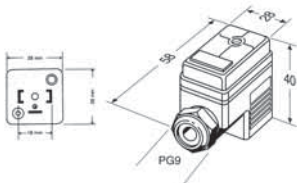

### PIN assignment

#### 705505

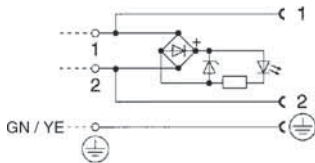

#### 705507

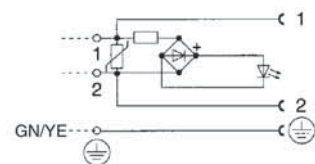

#### 707403

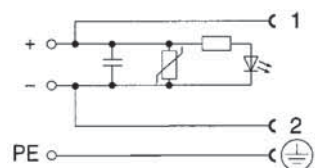

#### 705502

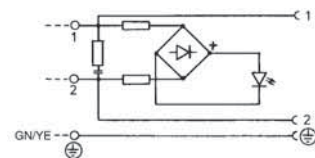

Description	Part-No.	Type	PU	
<b>Z-Diode</b>				
Nominal voltage	AC/DC 24 V	705505	LZ-V10-5505 AC/DC 24 V	10
<b>varistor</b>				
Nominal voltage	AC/DC 24 V	705507	LV-V10-5507 AC/DC 24 V	10
<b>Varistor + Capacitor</b>				
Nominal voltage	DC 24 V	707403	LCV-V10-7403 DC 24 V	10
<b>RC module</b>				
Nominal voltage	AC/DC 230 V	705502	LRC-V10-05602 AC/DC 230 V	10

Technical data	Z-Diode	varistor	Varistor + Capacitor	RC module
Function type	Suppressors for valves			
Protection device	Z-Diode	varistor		RC module
Nominal voltage	AC/DC 24 V		DC 24 V	AC/DC 230 V
Current Consumption per LED		4 mA		3 mA
Shut-off points	≤52 V		≤100 V	–
Rated frequency		50–60 Hz	–	50–60 Hz
Holding capacitance	15 VA	100 VA	50 VA	10 VA
Type of connecting lead			–	
Length of connecting lead (M)			–	
Connecting lead			∅ 5–9 mm	

### General

Form	Construction A, contact clearance 18 mm			
Status Indication	LED green			
Coil Current max.	≤4 A			
Conductor marking	–			
Housing material	PA black / transparent			
Protection class	IP 65			
Field installation	0° and 180° installation possible by rotating the coding disk			
Termination	Screw terminal: 0.5–1.5 mm <sup>2</sup>			
Operation temperature range	-20 °C – 60 °C			
Storage temperature range	-25 °C – 80 °C			
Dimensions (w × h × d)	28.0 × 40.0 × 58.0 mm			
Weight (kg/piece)	0.04			
Standards	EN 175301-803 (DIN 43 650), ISO 4400			
Approvals	–			

Accessories	Color	Article number	Type	PU
Plate 9×20mm	white	681315	BZT-0920	100

### Comments

# Suppression Technology - Valve Suppressors - special function

## Construction A (18 mm) adjustable plug Pressure switch / fill level monitor



### Dimensions

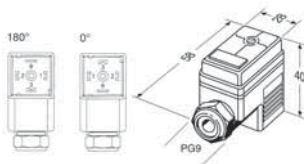

### PIN assignment

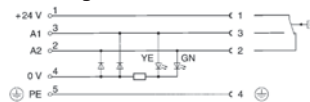

Description	Part-No.	Type	PU	
<b>Cable outlet 0°</b>				
Nominal voltage	DC 24 V	707508	LDS-V10-7508L 0° DC 24 V	10
<b>Cable outlet 180°</b>				
Nominal voltage	DC 24 V	707507	LDS-V10-7507R 180° DC 24 V	10
<b>Technical data</b>				
	<b>707508</b>	<b>707507</b>		
Function type	Pressure switch / function monitor			
Protection device	Diode			
Nominal voltage	DC 24 V			
Nominal voltage range	18 – 30 V			
Current Consumption per LED	16 mA			
Power	–			
Rise time	–			
Saturated voltage at max. current	–			
Switching thresholds	–			
Accuracy	–			
Control current	–			
Switching current	≤ 4 A			
Switching frequency	–			
Switch-on delay	–			
Switch-off delay	–			
Shut-off points	–			
Rated frequency	–			
Holding capacitance	1600 V / 1 A			
Type of connecting lead	–			
Length of connecting lead (M)	–			
Connecting lead	∅ 5–9 mm			
Fittings	PG 9			
Short-circuit protection	–			
<b>General</b>				
Form	Construction A, contact clearance 18 mm			
Status Indication	LED yellow + LED green			
Galvanic insulation I/O	–			
Clearance/creep. dist. (control/load side)	–			
Derating	–			
Conductor marking	–			
Housing material	PA transparent			
Protection class	IP 65			
Field installation	Breakaway torque 0.4 Nm			
Operation temperature range	-25 °C – 60 °C			
Storage temperature range	-25 °C – 80 °C			
Dimensions (w × h × d)	28.0 × 40.0 × 58.0 mm			
Weight (kg/piece)	0.036			
Standards	EN 175301-803 (DIN 43 650), ISO 4400			
Termination	Screw terminal: 0.5–1.5 mm <sup>2</sup>			
Approvals	–			
<b>Accessories</b>	<b>Color</b>	<b>Article number</b>	<b>Type</b>	<b>PU</b>
Tag holder 9×20 mm	white	681315	BZT-0920	100
<b>Comments</b>				

# Suppression Technology - Valve Suppressors - special function

## Adjustable male, form A (18 mm)

### Switching amplifier with and without galvanic insulation

### Ground wire terminator, short-circuit-proof, 0°–180° installation



#### Dimensions

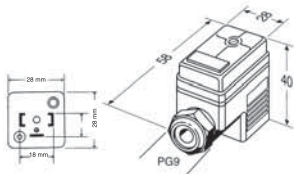

#### PIN assignment

##### 705509, 706509

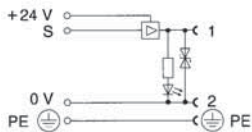

##### 707409

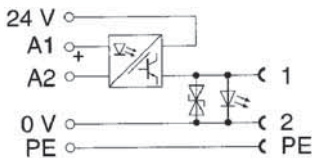

Description	Part-No.	Type	PU	
<b>without galvanic insulation</b>				
Nominal voltage	DC 24 V	705509	LVER-V10-5509 DC 24 V	10
	DC 24 V	706509	LVER-V10-6509 DC 24 V	10
<b>with galvanic insulation</b>				
Nominal voltage	DC 24 V	707409	LVER-V10-7409 DC 24 V	10
<b>Technical data</b>				
	<b>705509</b>	<b>706509</b>	<b>707409</b>	
Function type		Switching amplifier		
Protection device		Suppressor diode		
Nominal voltage		DC 24 V		
Nominal voltage range		18 – 30 V		
Current Consumption per LED	21 mA		7 mA	
Power		–		
Rise time		–		
Saturated voltage at max. current		–		
Switching thresholds		–		
Accuracy		–		
Control current	10 mA		7 mA	
Switching current	0.005A – 2A, short circuit protection			
Switching frequency		max. 20 Hz		
Switch-on delay		<100 µs		
Switch-off delay		<200 µs		
Shut-off points		≤52 V		
Rated frequency		–		
Holding capacitance		100 VA		
Type of connecting lead		–		
Length of connecting lead (M)		–		
Connecting lead		Ø 5–9 mm		
Fittings		PG 9		
Short-circuit protection		yes		
<b>General</b>				
Form	Construction A, contact clearance 18 mm			
Status Indication	LED yellow			
Galvanic insulation I/O	–	4.5 kV		
Clearance/creep. dist. (control/load side)	–	> 5.5 mm		
Derating	–			
Conductor marking	–			
Housing material	PA black / transparent	PA grey / transparent	PA black / transparent	
Protection class	IP 65			
Field installation	Breakaway torque 0.4 Nm			
Operation temperature range	-25 °C – 60 °C			
Storage temperature range	-25 °C – 80 °C			
Dimensions (w × h × d)	28.0 × 40.0 × 58.0 mm			
Weight (kg/piece)	0.039		0.044	
Standards	EN 175301-803 (DIN 43 650), ISO 4400			
Termination	Screw terminal: 0.5–1.5 mm <sup>2</sup>			
Approvals	–			
<b>Accessories</b>	<b>Color</b>	<b>Article number</b>	<b>Type</b>	<b>PU</b>
Tag holder 9×20 mm	white	681315	BZT-0920	100
<b>Comments</b>				

# Suppression Technology - Valve Suppressors - special function

## Adjustable male, form A (18 mm)

- Double valves
- Energy reducer



### Dimensions

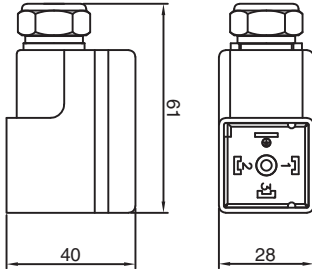

### PIN assignment

#### 705503

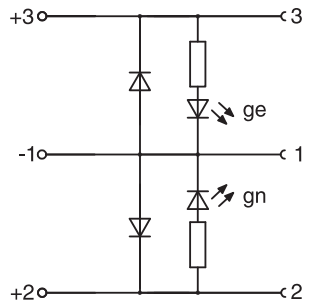

#### 707512

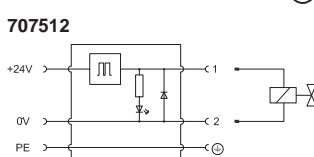

Description	Part-No.	Type	PU	
<b>Double valves</b>				
Nominal voltage	DC 24 V	705503	LD-V10-5503	10
<b>Energy reducer</b>				
Nominal voltage	DC 24 V	707512	LBM-V10-7512	10
<b>Technical data</b>				
	<b>705503</b>	<b>707512</b>		
Function type	Double valve plug	Energy reducer		
Protection device		Free-wheeling diode		
Nominal voltage		DC 24 V		
Nominal voltage range		18 – 30 V		
Current Consumption per LED	6 mA	24 mA		
Power		Reduction factor 40–70%, at delivery 50%		
Rise time		Pulse duration approx. 200 ms		
Saturated voltage at max. current	–	1.5 V		
Switching thresholds		–		
Accuracy		–		
Control current		–		
Switching current	≤4 A	≤2 A		
Switching frequency		–		
Switch-on delay		–		
Switch-off delay		–		
Shut-off points		–		
Rated frequency		–		
Holding capacitance		1000 V / 1 A		
Type of connecting lead		–		
Length of connecting lead (M)		–		
Connecting lead		∅ 5–9 mm		
Fittings		PG 9		
Short-circuit protection		–		
<b>General</b>				
Form		Construction A, contact clearance 18 mm		
Status Indication		LED green / LED yellow	LED yellow	
Galvanic insulation I/O		–		
Clearance/creep. dist. (control/load side)		–		
Derating		–		
Conductor marking		–		
Housing material		PA black / transparent		
Protection class		IP 65		
Field installation		Breakaway torque 0.4 Nm		
Operation temperature range		-25 °C – 60 °C		
Storage temperature range		-25 °C – 80 °C		
Dimensions (w × h × d)		28.0 × 40.0 × 58.0 mm		
Weight (kg/piece)		0.035		
Standards		EN 175301-803 (DIN 43 650), ISO 4400		
Termination		Screw terminal: 0.5–1.5 mm <sup>2</sup>		
Approvals		–		
<b>Accessories</b>	<b>Color</b>	<b>Article number</b>	<b>Type</b>	<b>PU</b>
Plate 9×20mm	white	681315	BZT-0920	100
<b>Comments</b>				

# Suppression Technology - Valve Suppressors - special function

## Adjustable plug; Construction A (18 mm)

- two cable entry points

Ground wire terminator (PE) adjustable in 180° steps



### Dimensions

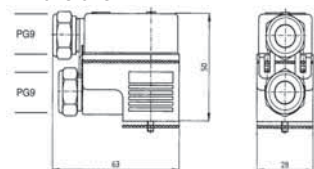

### PIN assignment

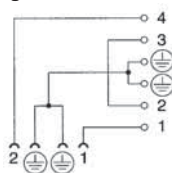

Description	Part-No.	Type	PU
<b>without protection device</b>			
Nominal voltage	AC/DC 0–230 V	707514	LPG-V10-7514 up to 230 V
			10
<b>Technical data</b>		<b>707514</b>	
Function type	Valve suppressors with two cable entry points		
Protection device	without		
Nominal voltage	AC/DC 0–230 V		
Nominal voltage range	0 – 230 V		
Current Consumption per LED	–		
Power	–		
Rise time	–		
Saturated voltage at max. current	–		
Switching thresholds	–		
Accuracy	–		
Control current	–		
Switching current	≤ 4 A		
Switching frequency	–		
Switch-on delay	–		
Switch-off delay	–		
Shut-off points	–		
Rated frequency	50–60 Hz		
Holding capacitance	–		
Type of connecting lead	–		
Length of connecting lead (M)	–		
Connecting lead	∅ 5–9 mm		
Fittings	PG 9		
Short-circuit protection	–		
<b>General</b>			
Form	Construction A, contact clearance 18 mm		
Status Indication	–		
Galvanic insulation I/O	–		
Clearance/creep. dist. (control/load side)	–		
Derating	–		
Conductor marking	–		
Housing material	PA black / transparent		
Protection class	IP 65		
Field installation	Breakaway torque 0.4 Nm		
Operation temperature range	-25 °C – 60 °C		
Storage temperature range	-25 °C – 80 °C		
Dimensions (w × h × d)	28.0 × 50.0 × 63.0 mm		
Weight (kg/piece)	0.030		
Standards	EN 175301-803 (DIN 43 650), ISO 4400		
Termination	Screw terminal: 0.5–1.5 mm <sup>2</sup>		
Approvals	–		
<b>Accessories</b>	<b>Color</b>	<b>Article number</b>	<b>Type</b>
Tag holder 9×20 mm	white	681315	BZT-0920
<b>Comments</b>			



# Suppression Technology - Suppressors for valves

Adjustable male, form B DIN (10 mm) and BI (11 mm)  
 Ground wire terminator (PE) adjustable in 180° steps by turning the coding disk  
 Protection device: without circuit / Z-Diode+LED / Varistor+LED



### Dimensions

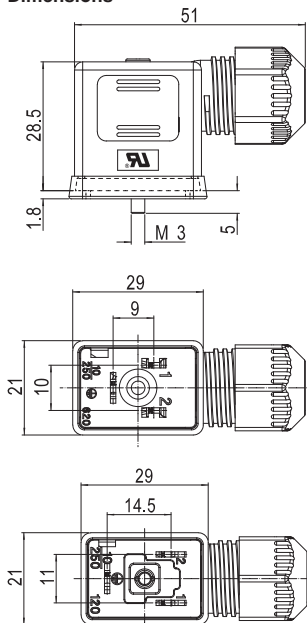

### PIN assignment

705802, 705803

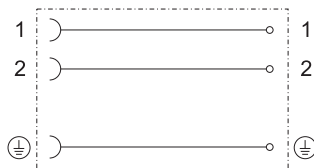

705811, 705812

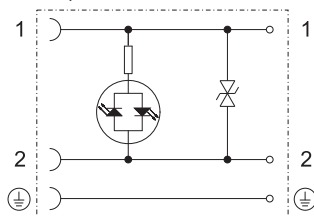

705831, 705832

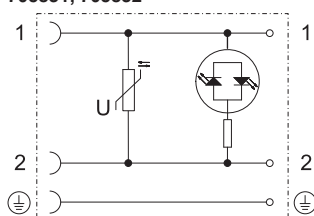

Description	Part-No.	Type	PU			
<b>without circuit</b>						
Nominal voltage	AC/DC 0–230 V	705802	L-V21-5802 AC/DC 0-230 V	1		
	AC/DC 0–230 V	705803	L-V22-5832 AC/DC 0-230 V	1		
<b>Z-diode + LED</b>						
Nominal voltage	AC/DC 24 V	705811	LS-V21-5811 AC/DC 24 V	1		
	AC/DC 24 V	705812	LS-V22-5812 AC/DC 24 V	1		
<b>Varistor + LED</b>						
Nominal voltage	AC/DC 110–230 V	705831	LV-V21-5831 AC/DC 110-230 V	1		
	AC/DC 110–230 V	705832	LV-V22-5832 AC/DC 110-230 V	1		
<b>Technical data</b>						
	<b>705802</b>	<b>705803</b>	<b>705811</b>	<b>705812</b>	<b>705831</b>	<b>705832</b>
Function type	Suppressors for valves					
Pol number	2-pole + PE					
Protection device	without circuit		Z-diode + LED		Varistor + LED	
Nominal voltage	AC/DC 0–230 V		AC/DC 24 V		AC/DC 110–230 V	
Rated frequency	50–60 Hz					
Connecting lead	Ø 4 – 9 mm					
<b>General</b>						
Form	B DIN, contact clearance 10 mm	BI, Contact clearance 11 mm	B DIN, contact clearance 10 mm	BI, Contact clearance 11 mm	B DIN, contact clearance 10 mm	BI, Contact clearance 11 mm
Status Indication	LED yellow					
Switching current	10 A		4 A		1 A	
Housing material	PA black UL94-V0			PA transparent UL94-HB		
Protection class	IP 67					
Field installation	Breakaway torque 0.4 Nm					
Termination	Screw terminal max. 18 AWG / 1.5 mm <sup>2</sup>					
Seal	NBR					
Operation temperature range	–40 °C – 90 °C					
Dimensions (w × h × d)	21.0 × 30.3 × 51.0 mm					
Weight (kg/piece)	0.02					
Standards	EN 175301-803 (DIN 43 650)					
Approvals	UL recognized					

# Suppression Technology - Suppressors for valves

## Adjustable plug Construction B (10 mm) and BI (11 mm) Ground wire terminator (PE) adjustable in 180° steps



### Dimensions

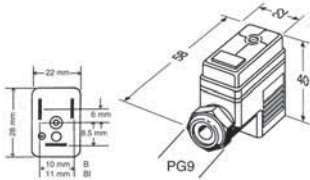

### PIN assignment

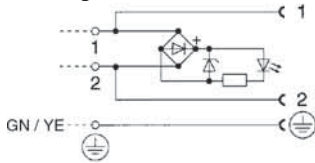

Description	Part-No.	Type	PU	
<b>Construction B</b>				
Nominal voltage	AC/DC 24 V	705605	LZ-V11-5605 AC/DC 24 V	10
<b>Construction BI</b>				
Nominal voltage	AC/DC 24 V	705705	LZ-V12-5705 AC/DC 24 V	10
<b>Technical data</b>				
	<b>Construction B</b>	<b>Construction BI</b>		
Function type	Suppressors for valves			
Protection device	Z-Diode			
Nominal voltage	AC/DC 24 V			
Current Consumption per LED	4 mA			
Shut-off points	≤52 V			
Rated frequency	50–60 Hz			
Holding capacitance	15 VA			
Type of connecting lead	–			
Length of connecting lead (M)	–			
Connecting lead	∅ 5–9 mm			
<b>General</b>				
Form	Design B, contact clearance 10 mm	Form B, contact clearance 11 mm		
Status Indication	LED green			
Coil Current max.	–			
Conductor marking	–			
Housing material	PA black / transparent			
Protection class	IP 65			
Field installation	0° and 180° installation possible by rotating the coding disk			
Termination	Screw terminal: 0.5–1.5 mm <sup>2</sup>			
Operation temperature range	-25 °C – 60 °C			
Storage temperature range	-25 °C – 80 °C			
Dimensions (w × h × d)	22.0 × 40.0 × 58.0 mm			
Weight (kg/piece)	0.03			
Standards	EN 175301-803 (DIN 43 650), ISO 6952			
Approvals	–			
<b>Accessories</b>				
	<b>Color</b>	<b>Article number</b>	<b>Type</b>	<b>PU</b>
Plate 9×20mm	white	681315	BZT-0920	100
<b>Comments</b>				

# Suppression Technology - Valve Suppressors - special function

**Adjustable connector, Construction B (10 mm), Construction BI (11 mm)**  
**Switching amplifier without galvanic insulation short circuit protection**  
**Ground wire terminator (PE) adjustable in 180° steps**



## Dimensions

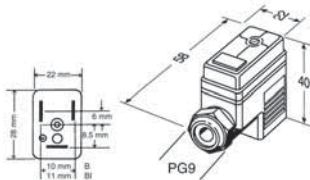

## PIN assignment

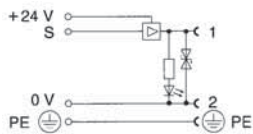

Description	Part-No.	Type	PU	
<b>Construction B</b>				
Nominal voltage	DC 24 V	705610	LVER-V11-5610 DC 24 V	10
<b>Construction BI</b>				
Nominal voltage	DC 24 V	705709	LVER-V12-5709 DC 24 V	10
<b>Technical data</b>				
	<b>705610</b>	<b>705709</b>		
Function type		Switching amplifier		
Protection device		Suppressor diode		
Nominal voltage		DC 24 V		
Nominal voltage range		18 – 30 V		
Current Consumption per LED		19 mA		
Power		–		
Rise time		–		
Saturated voltage at max. current		–		
Switching thresholds		–		
Accuracy		–		
Control current		8 mA		
Switching current		0.005A – 2A		
Switching frequency		max. 20 Hz		
Switch-on delay		<100 µs		
Switch-off delay		<200 µs		
Shut-off points		≤52 V		
Rated frequency		–		
Holding capacitance		100 VA		
Type of connecting lead		–		
Length of connecting lead (M)		–		
Connecting lead		∅ 5–9 mm		
Fittings		PG 9		
Short-circuit protection		yes		
<b>General</b>				
Form	Construction B	Construction BI		
Status Indication		LED green		
Galvanic insulation I/O		No		
Clearance/creep. dist. (control/load side)		–		
Derating		No		
Conductor marking		–		
Housing material		PA black / transparent		
Protection class		IP 65		
Field installation		Breakaway torque 0.4 Nm		
Operation temperature range		-25 °C – 60 °C		
Storage temperature range		-25 °C – 80 °C		
Dimensions (w × h × d)		22.0 × 40.0 × 58.0 mm		
Weight (kg/piece)		0.036		
Standards	EN 175301-803 (DIN 43 650), ISO 6952	–		
Termination		Screw terminal: 0.5–1.5 mm <sup>2</sup>		
Approvals		–		
<b>Accessories</b>				
	<b>Color</b>	<b>Article number</b>	<b>Type</b>	<b>PU</b>
Plate 9×20mm	white	681315	BZT-0920	100
<b>Comments</b>				

# Suppression Technology - Suppressors for valves

Adjustable male, form C DIN (8 mm) and CI (9.4 mm)

Ground wire terminator (PE) adjustable in 90° steps by turning the coding disk

Protection device: without circuit / Z-Diode+LED / Varistor+LED



## Dimensions

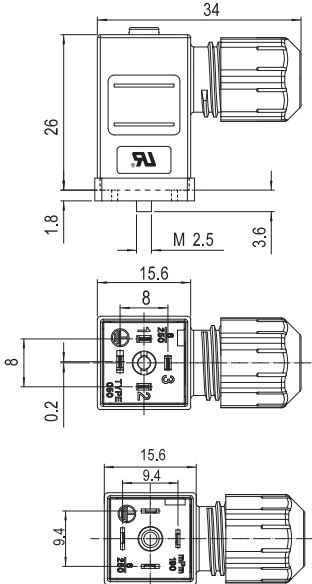

## PIN assignment

### 705804, 705805

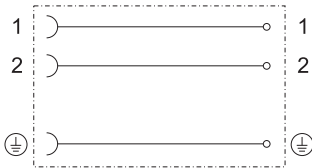

### 705813, 705814

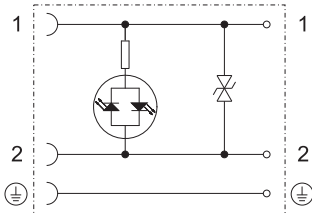

### 705833, 705834

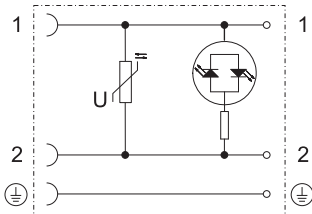

Description	Part-No.	Type	PU	
<b>without circuit</b>				
Nominal voltage	AC/DC 0–230 V	705804	L-V23-5804 AC/DC 0-230 V	1
	AC/DC 0–230 V	705805	L-V24-5805 AC/DC 0-230 V	1
<b>Z-diode + LED</b>				
Nominal voltage	AC/DC 24 V	705813	LS-V23-5813 AC/DC 24 V	1
	AC/DC 24 V	705814	LS-V24-5814 AC/DC 24 V	1
<b>Varistor + LED</b>				
Nominal voltage	AC/DC 110–230 V	705833	LV-V23-5833 AC/DC 110-230 V	1
	AC/DC 110–230 V	705834	LV-V24-5834 AC/DC 110-230 V	1

Technical data	705804	705805	705813	705814	705833	705834
Function type	Suppressors for valves					
Pol number	2-pole + PE					
Protection device	without circuit		Z-diode + LED		Varistor + LED	
Nominal voltage	AC/DC 0–230 V		AC/DC 24 V		AC/DC 110–230 V	
Rated frequency	50–60 Hz					
Connecting lead	Ø 3 – 5.5 mm					
<b>General</b>						
Form	C DIN, contact clearance 8 mm	CI, Contact clearance 9.4 mm	C DIN, contact clearance 8 mm	CI, Contact clearance 9.4 mm	C DIN, contact clearance 8 mm	CI, Contact clearance 9.4 mm
Status Indication	LED yellow					
Switching current	6 A		3 A		0.5 A	
Housing material	PA black UL94-V0		PA transparent UL94-HB			
Protection class	IP 67					
Field installation	Breakaway torque 0.4 Nm					
Termination	Screw terminal max. 18 AWG / 1.5 mm <sup>2</sup>					
Seal	NBR					
Operation temperature range	–40 °C – 60 °C					
Dimensions (w × h × d)	15.6 × 27.8 × 34.0 mm					
Weight (kg/piece)	0.01					
Standards	EN 175301-803 (DIN 43 650)					
Approvals	UL recognized					

# Suppression Technology - Valve Suppressors

## Plug adaptor for valve suppressors type A Contact clearance 18 mm EN 175301-803 (DIN 43 650)



### Dimensions

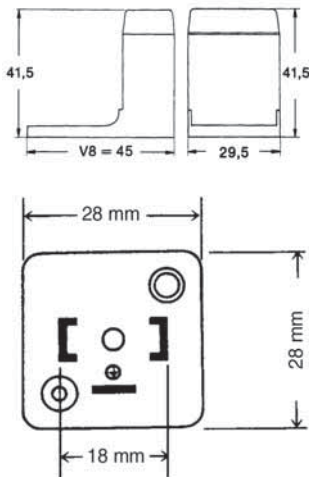

### PIN assignment

700861, 700863

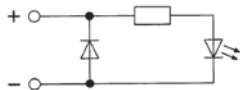

700897

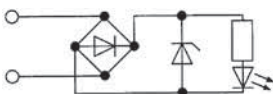

700881

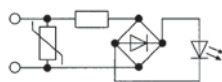

700867

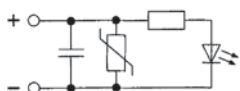

700910, 700857



Description		Part-No.	Type	PU
<b>Diode + LED</b>				
Nominal voltage	DC 24 V	700861	LD-V8-0861 DC 24 V	20
Nominal voltage	DC 24 V	700863	LD-V8-0863 DC 24 V	20
<b>Z-Diode</b>				
Nominal voltage	AC/DC 24 V	700897	LZ-V8-0897 AC/DC 24 V	20
<b>varistor</b>				
Nominal voltage	AC/DC 24 V	700881	LV-V8-0881N AC/DC 24 V	20
<b>Varistor + Capacitor</b>				
Nominal voltage	DC 24 V	700867	LCV-V8T-0867 DC 24 V	20
<b>RC module</b>				
Nominal voltage	AC 115 V	700910	LRC-V8-0910 AC 115 V	20
Nominal voltage	AC 230 V	700857	LRC-V8-0857 AC 230 V	20

Technical data	700861	700863	700897	700881	700867	700910	700857
Function type	Plug adaptor						
Protection device	Diode + LED		Z-Diode	varistor	Varistor + Capacitor	RC module	
Nominal voltage	DC 24 V		AC/DC 24 V		DC 24 V	AC 115 V	AC 230 V
Current Consumption per LED			4 mA				
Shut-off points	1 V		≤52 V	≤100 V	≤250 V		≤300 V
Rated frequency	-		50-60 Hz		-		50-60 Hz
Holding capacitance	1600 V / 1 A	1300 V / 3 A	15 VA	200 VA	50 VA	10 VA	
<b>General</b>							
Form	Plug adaptor V8		A (V8)		A (V8T)		A (V8)
Status Indication			LED green		Glow lamp		
Coil Current max.							
Conductor marking							
Housing material	PA black / transparent						
Protection class	IP 65						
Field installation	pluggable on solenoid coil, plug seal not applicable						
Operation temperature range	-20 – 60 °C						
Storage temperature range	-25 – 80 °C						
Dimensions (w × h × d)	29.5 × 41.5 × 45.0 mm						
Weight (kg/piece)	0.010						
Standards	EN 175301-803 (DIN 43 650), ISO 4400						
Approvals							

# Suppression Technology - Valve Suppressors

## Plug adaptor for valve suppressors type BI (11 mm) Contact arrangement in 0° and 180° construction



### Dimensions

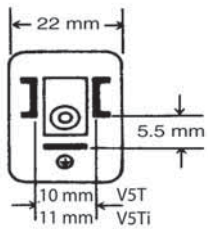
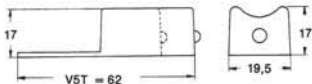

### PIN assignment

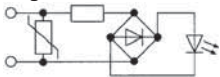

Description	Part-No.	Type	PU	
Nominal voltage	AC/DC 24 V	705341	LV-V5TI-5341 0° AC/DC 24 V	10
	AC/DC 24 V	705141	LV-V5TI-5141 180° AC/DC 24 V	10

Technical data	705341	705141
Function type	Plug adaptor V5T, V5TI	
Protection device	Varistor + LED	
Nominal voltage	AC/DC 24 V	
Current Consumption per LED	4 mA	
Shut-off points	≤100 V	
Rated frequency	50–60 Hz	
Holding capacitance	200 VA	
<b>General</b>		
Form	DesignBI (V5TI)	
Status Indication	LED green	
Coil Current max.	–	
Conductor marking	–	
Housing material	PA black	
Protection class	IP 65 assembled	
Field installation	pluggable on solenoid coil, plug seal not applicable	
Operation temperature range	-20 – 60 °C	
Storage temperature range	-25 – 80 °C	
Dimensions (w × h × d)	19.5 × 17.0 × 62.0 mm	
Weight (kg/piece)	0.016	
Standards	–	
Approvals	–	

# Suppression Technology - Motor suppression

Motor suppression for the direct installation in the motor junction plate  
 5.5 kW to 7.5 kW, 3 AC x 500 V  
 Protection device: Varistor



### Dimensions

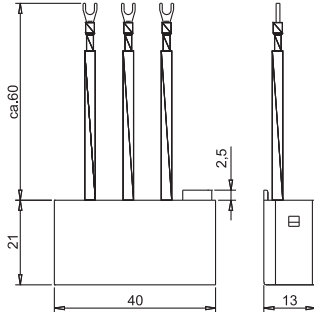

### PIN assignment

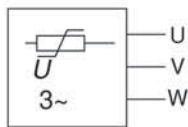

Description	Part-No.	Type	PU	
<b>varistor</b>				
Description	varistor	706120	LV-S10-6120 3 AC 500 V 5,5 kW	10
	varistor	706121	LV-S10-6121 3 AC 500 V 7,5 kW	10

Technical data	706120	706121
Function type	Motor suppression	
Protection device	varistor	
Nominal voltage	3 ACx500 V	
Shut-off points	≤1075 V	
Rated frequency	10–400 Hz	
Motor performance	5.5 kW	7.5 kW
Inverse voltage/switching current	–	
Holding capacitance	–	
Type of connecting lead	LIH; 1.5 mm <sup>2</sup> ; black	
Length of connecting lead (M)	0.059	
Connecting lead	–	
Termination	3 wires with fork-type cable lug M5	
Fittings	–	
<b>General</b>		
Form	S10	
Status Indication	–	
Conductor marking	–	
Housing material	PA 6.6	
Protection class	IP 67	
Pottant	2-components	
Field installation	for inserting in the motor junction plate	
Operation temperature range	-20 °C – 60 °C	
Storage temperature range	-40 °C – 90 °C	
Dimensions (w × h × d)	40.0 × 21.0 × 13.0 mm	
Weight (kg/piece)	0.023	
Standards	–	
Approvals	cURus	

# Suppression Technology - Motor suppression

Motor suppression for the screwing in in the motor terminal box  
 also suitable for frequency converters up to 7.5 kW, 3 AC x 575 V  
 Protection device: Varistor



Description	Part-No.	Type	PU	
Description	Varistor	701533	LV-RM1-1533 3 AC 575 V 4 kW	10
	Varistor	701534	LV-RM2-1534 3 AC 575 V 7,5kW	10

Technical data	701533	701534
Function type	Motor suppression	
Protection device	varistor	
Nominal voltage	3 ACx575 V	
Shut-off points	≤1075 V	
Rated frequency	10–400 Hz	
Motor performance	4 kW	7.5 kW
Inverse voltage/switching current	–	
Holding capacitance	–	
Type of connecting lead	H07V-K 1.5 mm <sup>2</sup> , black	
Length of connecting lead (M)	0.12	0.15
Connecting lead	–	
Termination	Ring terminal M5	Ring terminal M6
Fittings	M16 x 1.5	M32 x 1.5
Suppression type	–	
<b>General</b>		
Form	RM1	RM2
Status Indication	–	
Conductor marking	–	
Housing material	PPO	
Protection class	IP 67	
Pottant	2-components	
Field installation	Screwed into terminal housing directly	
Operation temperature range	-20 °C – 60 °C	
Storage temperature range	-40 °C – 90 °C	
Dimensions (w × h × d)	28.5 × 45.5 × 24.0 mm	38.0 × 45.5 × 36.0 mm
Weight (kg/piece)	0.040	0.075
Standards	–	
Approvals	cURus	

## Dimensions

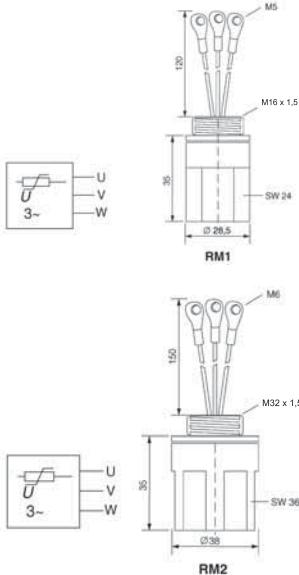

## PIN assignment

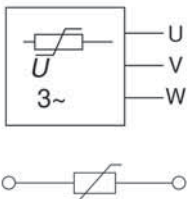



# Suppression Technology - Motor suppression

Motor suppression for the direct installation in the motor junction plate  
 7.5 kW, 3 AC x 500 V  
 Protection device: RC module



Dimensions

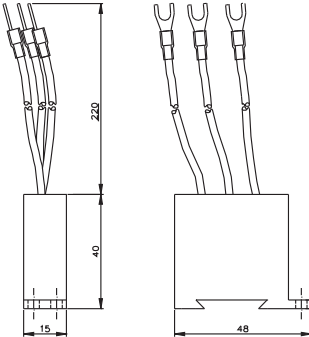

PIN assignment

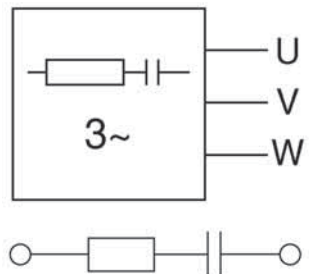

Description	Part-No.	Type	PU
<b>RC module</b>			
Description	RC module	706115	LRC-VM1-6115 3 AC 500 V 7,5 kW
			25
<b>Technical data</b>		<b>706115</b>	
Function type	Motor suppression		
Protection device	RC module		
Nominal voltage	3 ACx500 V		
Shut-off points	-		
Rated frequency	50-60 Hz		
Motor performance	7.5 kW		
Inverse voltage/switching current	-		
Holding capacitance	-		
Type of connecting lead	H05V-K 1.0 mm <sup>2</sup> ; black		
Length of connecting lead (M)	0.22		
Connecting lead	-		
Termination	3 wires with fork-type cable lug M4		
Fittings	-		
<b>General</b>			
Form	VM1		
Status Indication	-		
Conductor marking	-		
Housing material	PPO		
Protection class	IP 67		
Pottant	2-components		
Field installation	For inserting in the motor junction plate, for the bolting on with mounting hole M4 or for attachment to hat profile TS35 with 2 snap-on sockets (accessory)		
Operation temperature range	-20 °C – 60 °C		
Storage temperature range	-40 °C – 90 °C		
Dimensions (w × h × d)	15.0 × 40.0 × 48.0 mm		
Weight (kg/piece)	0.049		
Standards	-		
Approvals	cURus		
<b>Accessories</b>			
	<b>Color</b>	<b>Article number</b>	<b>Description</b>
Snap-on socket for hat profile TS35		700499	Socket for attaching of the suppressor module to hat profile TS35 (EN 50022) or G-rails
			10

# Suppression Technology - Motor suppression

Motor suppression for the screwing in in the motor terminal box  
up to 7.5 kW, 3 AC x 575 V  
Protection device: RC module



Description	Part-No.	Type	PU	
Description	RC module	700374	LRC-M5-0374 3 AC 500 V 4 kW	10
	RC module	700379	LRC-M5-0379 3 AC 575 V 7,5 kW	10

Technical data	700374	700379
Function type	Motor suppression	
Protection device	RC module	
Nominal voltage	3 ACx500 V	3 ACx575 V
Shut-off points	-	
Rated frequency	50-60 Hz	
Motor performance	4 kW	7.5 kW
Inverse voltage/switching current	-	
Holding capacitance	-	
Type of connecting lead	PVC 3 x 1.0 mm <sup>2</sup>	
Length of connecting lead (M)	0.5	
Connecting lead	Ø 6.3 mm	
Termination	Ring terminal M5	Ring terminal M6
Fittings	PG 9	
<b>General</b>		
Form	M5	
Status Indication	-	
Conductor marking	-	
Housing material	PA 6.6	
Protection class	IP 67	
Pottant	2-components	
Field installation	Can be screwed in directly in the terminal housing, with cable ties at the motor supply line for fixing or with 2 snap-on sockets (accessory)	
Operation temperature range	-20 °C – 60 °C	
Storage temperature range	-40 °C – 90 °C	
Dimensions (w x h x d)	40.0 x 40.0 x 40.0 mm	
Weight (kg/piece)	0.113	
Standards	-	
Approvals	cURus	

## Dimensions

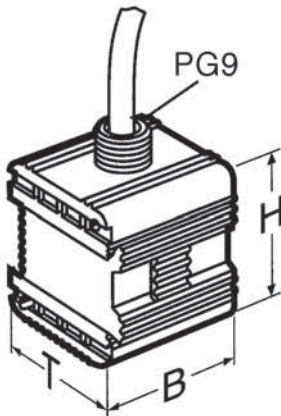

## PIN assignment

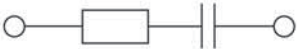
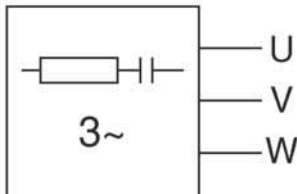

Accessories	Color	Article number	Description	PU
Snap-on socket for hat profile TS35		700499	Socket for attaching of the suppressor module to hat profile TS35 (EN 50022) or G-rails	10

# Suppression Technology - Motor suppression

Motor suppression in the M1, M2 and M3 enclosure  
for AC motors up to 30 kW, 3 AC x 500 V  
Protection device: RC module



## Dimensions

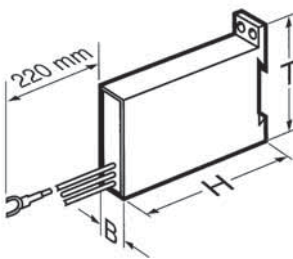

## PIN assignment

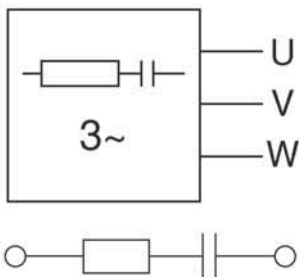

Description	Part-No.	Type	PU	
Description	RC module	700490	LRC-M1-0490 3 AC 500 V 4 kW	10
	RC module	700491	LRC-M2-0491 3 AC 500 V 7,5 kW	10
	RC module	700492	LRC-M2-0492 3 AC 500 V 15 kW	10
	RC module	700493	LRC-M3-0493 3 AC 500 V 30 kW	10

Technical data	700490	700491	700492	700493
Function type	Motor suppression			
Protection device	RC module			
Nominal voltage	3 ACx500 V			
Shut-off points	-			
Rated frequency	50-60 Hz			
Motor performance	4 kW	7.5 kW	15 kW	30 kW
Inverse voltage/switching current	-			
Holding capacitance	-			
Type of connecting lead	H05V-K 1.0 mm <sup>2</sup>			
Length of connecting lead (M)	0.22			
Connecting lead	-			
Termination	Fork-type cable lug M4			
Fittings	-			
Suppression type	Motor connection delta			
<b>General</b>				
Form	M1	M2	M3	
Status Indication	-			
Conductor marking	-			
Housing material	PPO			
Protection class	IP 67			
Pottant	2-components			
Field installation	with mounting hole M4 or attachable to TS 35 (EN 50022) with 2 snap-on sockets each			
Operation temperature range	-20 °C – 60 °C			
Storage temperature range	-40 °C – 90 °C			
Dimensions (w × h × d)	15.0 × 70.0 × 48.0 mm	20.0 × 80.0 × 58.0 mm	25.0 × 90.0 × 58.0 mm	
Weight (kg/piece)	0.066	0.112	0.119	0.120
Standards	-			
Approvals	cURus			
<b>Accessories</b>	<b>Color</b>	<b>Article number</b>	<b>Description</b>	<b>PU</b>
Snap-on socket for hat profile TS35		700499	Socket for attaching of the suppressor module to hat profile TS35 (EN 50022) or G-rails	10

# Suppression Technology - Motor suppression

Universal motor suppression: direct attachment to the switch (e.g. Siemens SIRIUS 3RT 10)  
also suitable for frequency converters up to 7.5 kW, 3 AC x 575 V

Protection device: Varistor



Description	Part-No.	Type	PU
<b>varistor</b>			
Description	varistor	706167 LV-VM1-6167 3 AC 575V 7,5KW	10
<b>Technical data</b>		<b>706167</b>	
Function type	Motor suppression		
Protection device	varistor		
Nominal voltage	3 ACx575 V		
Shut-off points	≤1075 V		
Rated frequency	10–400 Hz		
Motor performance	7.5 kW		
Inverse voltage/switching current	–		
Holding capacitance	–		
Type of connecting lead	H07V-U 1.5 mm <sup>2</sup> , black		
Length of connecting lead (M)	0.03		
Connecting lead	–		
Termination	stripped cable ends		
Fittings	–		
<b>General</b>			
Form	VM1		
Status Indication	–		
Conductor marking	–		
Housing material	PPO		
Protection class	IP 67		
Pottant	2-components		
Field installation	for direct attachment to switches		
Operation temperature range	-20 °C – 60 °C		
Storage temperature range	-40 °C – 90 °C		
Dimensions (w × h × d)	15.0 × 40.0 × 40.5 mm		
Weight (kg/piece)	0.015		
Standards	–		
Approvals	cJURus		

## Dimensions

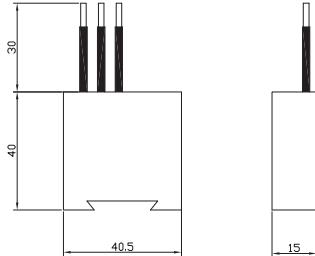

## PIN assignment

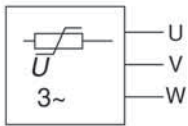

# Suppression Technology - Motor suppression

As substructure for protection types up to 45 mm wide

2.5 kW, 3 AC x 400 V

Protection device: Varistor



## Dimensions

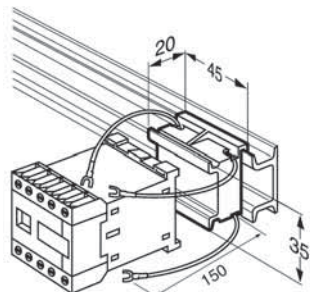

## PIN assignment

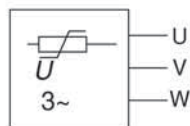

Description	Part-No.	Type	PU
<b>varistor</b>			
Description	varistor	700217	LV-S9-0217 3 AC 400 V 2,5 kW
<b>Technical data</b>			
		<b>700217</b>	
Function type	Motor suppression		
Protection device	varistor		
Nominal voltage	3 ACx400 V		
Shut-off points	≤745 V		
Rated frequency	10–400 Hz		
Motor performance	2.5 kW		
Inverse voltage/switching current	–		
Holding capacitance	–		
Type of connecting lead	H05V-K 1.0 mm <sup>2</sup>		
Length of connecting lead (M)	0.15		
Connecting lead	–		
Termination	Fork-type cable lug M4		
Fittings	–		
<b>General</b>			
Form	S9		
Status Indication	–		
Conductor marking	–		
Housing material	PC		
Protection class	IP 20		
Pottant	–		
Field installation	rail TS 35 (EN 50022)		
Operation temperature range	-20 °C – 60 °C		
Storage temperature range	-40 °C – 90 °C		
Dimensions (w × h × d)	40.0 × 20.0 × 35.0 mm		
Weight (kg/piece)	0.036		
Standards	–		
Approvals	–		

# Suppression Technology - Motor suppression

As substructure for protection types up to 45 mm wide  
up to 15 kW, 3 AC x 575 V  
Protection device: RC module



## Dimensions

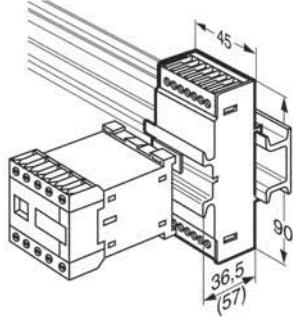

## PIN assignment

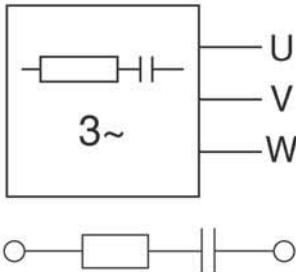

Description	Part-No.	Type	PU	
Description	RC module	700190	LRC-UC-0190 3 AC 500 V 4 kW	10
	RC module	700191	LRC-UC-0191 3 AC 500 V 7,5 kW	10
	RC module	700192	LRC-UC-0192 3 AC 500 V 15 kW	10

Technical data	700190	700191	700192
Function type		Motor suppression	
Protection device		RC module	
Nominal voltage		3 ACx575 V	
Shut-off points		-	
Rated frequency		50-60 Hz	
Motor performance	4 kW	7.5 kW	15 kW
Inverse voltage/switching current		-	
Holding capacitance		-	
Type of connecting lead		H05V-K 1.0 mm <sup>2</sup>	
Length of connecting lead (M)		0.2	
Connecting lead		-	
Termination		3 wires with fork-type cable lug M4	
Fittings		-	
Suppression type		-	
<b>General</b>			
Form		UC	
Status Indication		-	
Conductor marking		-	
Housing material		PC	
Protection class		IP 20	
Pottant		-	
Field installation		rail TS 35 (EN 50022)	
Operation temperature range		-20 °C – 60 °C	
Storage temperature range		-40 °C – 90 °C	
Dimensions (w × h × d)		40.0 × 36.5 × 90.0 mm	
Weight (kg/piece)	0.086	0.110	0.120
Standards		-	
Approvals		-	

# Suppression Technology - Components with special function

**Adjustable switch-on delays, time range 0.5 s - 20 s**  
**Enclosure type: S2, V1**  
**for AC and DC operation**



Dimensions

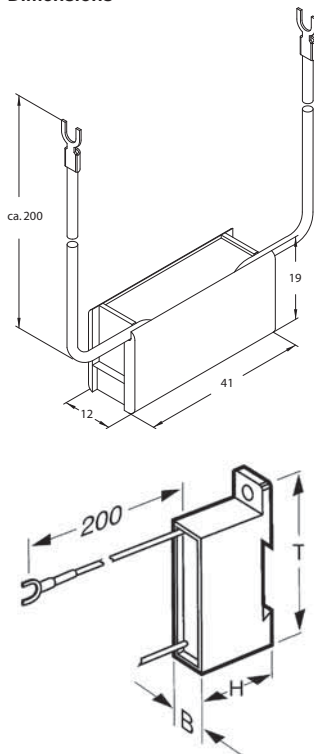

PIN assignment

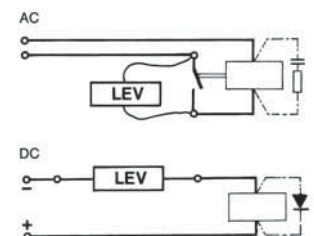

Description	Part-No.	Type	PU	
Nominal voltage	AC/DC 24–230 V	700527	LEV-S2-0527 AC/DC 24-230 V	10
	AC/DC 24–230 V	700529	LEV-V1-0529 AC/DC 24-230 V	10

Technical data	700527	700529
Function type	Switch-on delay	
Protection device	–	
Nominal voltage	AC/DC 24–230 V	
Rated frequency	50–60 Hz	
Voltage trim range	0.5 s–20 s over potentiometer	
Repeat accuracy	<15 %	
Type of connecting lead	PVC 0.5 mm <sup>2</sup>	
Length of connecting lead (M)	0.2	
Connecting lead	–	
Termination	Fork-type cable lug M4	
<b>General</b>		
Form	S2	V1
Pottant	2-components	
Housing material	PPO	
Protection class	IP 20	
Field installation	insertable in top hat rail or with retaining clips (accessory)	with mounting hole M4 or attachable to hat profile TS 35 with snap-on socket (accessory)
Operation temperature range	-20 °C – 60 °C	
Storage temperature range	-40 °C – 90 °C	
Dimensions (w × h × d)	41.0 × 19.0 × 12.0 mm	12.5 × 48.0 × 25.0 mm
Weight (kg/piece)	0.016	0.020
Standards	–	
Approvals	–	

Accessories	Color	Article number	Description	PU
Snap-on socket for hat profile TS35		700499	Socket for attaching of the suppressor module to hat profile TS35 (EN 50022) or G-rails	10
Retaining clip for type S2	transparent	700419	For the mounting of the suppressor module to the connection wires	10

**Comments**

Mounting diagram

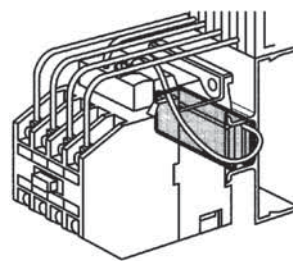

Mounting diagram

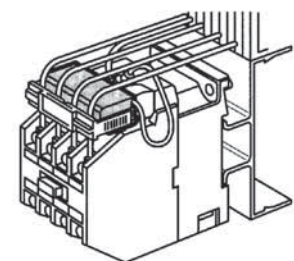





## 9. Installation accessories

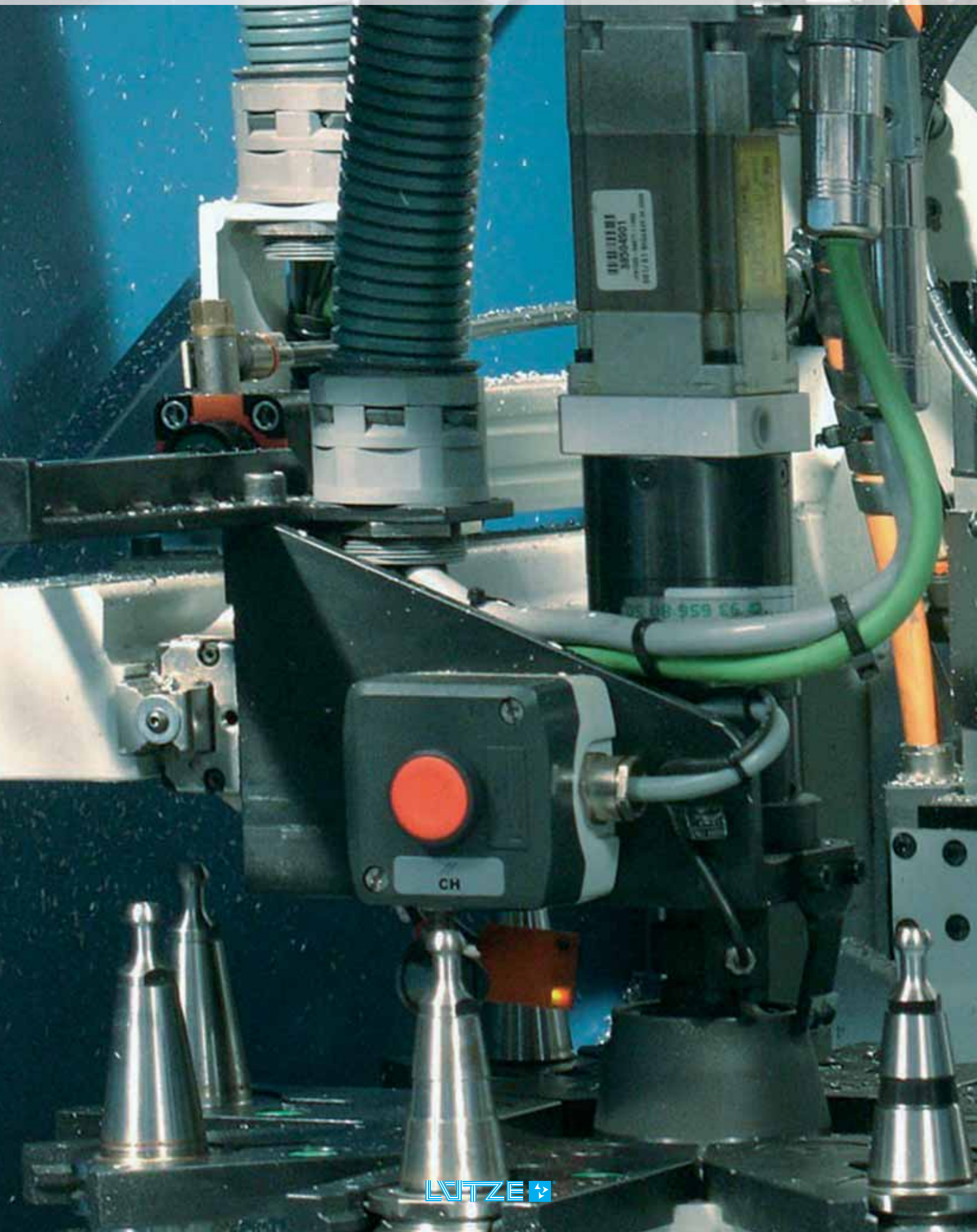

## 9. Installation accessories

Application		
<b>Entry system</b>		
Cablefix Vario, Cablefix	Cable entry system for connectorized cables	9.3 - 9.5
<b>Plastic fittings</b>		
TOP-T-P, TOP-TR-P	Cable fittings with strain relief and IP rated seal	9.6 - 9.8
<b>Plastic accessories</b>		
Locknuts GK	Accessories for use with plastic fittings	9.9 - 9.10
Reducer RR		9.11
Blanking plugs BL		9.12
<b>Metal fittings</b>		
TOP-T, TOP-TR	Cable fittings with strain relief and IP rated seal	9.13 - 9.16
TOP-T-S-EMV 1, TOP-T-S-EMV 2	Optional with shield termination	
<b>Metal accessories</b>		
Locknuts GMS, Locknuts GMS EMV	Accessories for use with metal fittings	9.17 - 9.18
Reducer RR, Enlarger EW		9.19 - 9.20
Blanking plugs BLMS		9.21
<b>Plastic and metal accessories</b>		
Multiple sealing insert MFDE	Sealing insert for retroactive installation in plastic and metal fitting applications	9.22
Sealing insert ASI DE		9.23
<b>Mounting accessories</b>		
Control panel installation	Socket for fully protected wire connections and integrated snap connection for simple and quick installation	9.24
Cable tie	For bundling of cables, conductors or conduits	9.25
Identification of hook-up wires and cables	Tags for labeling of cables and conduits	9.26
Laser labels	For the printing with laser printer	9.27
Marker strips	Marker strips flexible and self-adhesive	9.28

# Cable fittings and accessories

## Cablefix Vario

### Feed-through for all prefabricated cables and wires with connectors



#### Technical data

Temperature range	-40 °C to +135 °C
Burning behavior	Flame-retardant
Module type	VG=40×43.5 VK=40×22.9 for cable and wire diameters from 4 mm to 34.5 mm, see ordering information
Protection class	IP 65

#### Construction

- Frame AKLR from smooth ground aluminum
- Frame KKLR from polyamide GF50 glass fibre reinforced
- Modules slotted to the right from the borings

Part-No.	Type	Dimensions (w x h x d) mm	Unit VK/VG	PU piece	With flat seal and drilling template	Comments
<b>Terminal frame as feed-through system with strain relief</b>						
606052	KKLR 1	136.0 × 71.0 × 30.0	4/2	1	Yes	Master gauge for holes HAN 16 B attachment housing
606053	KKLR 2	164.0 × 71.0 × 30.0	6/3	1	Yes	Master gauge for holes HAN 24 B attachment housing
<b>Aluminium smooth-ground, also available as anodised</b>						
606038	AKLR0	68.0 × 30.0	2/1	1	Yes	Hole ø 6.5 hole dimensions 30 × 55 with flat seal
606001	AKLR 1	68.0 × 30.0	4/2	1	Yes	
606002	AKLR 2	68.0 × 30.0	6/3	1	Yes	
606003	AKLR 3	88.0 × 30.0	9/3+3	1	Yes	
606004	AKLR 4	108.0 × 30.0	12/6	1	Yes	
606005	AKLR 5	78.0 × 30.0	8/4	1	Yes	
606006	AKLR 6	98.0 × 30.0	12/4+4	1	Yes	
606007	AKLR 7	118.0 × 30.0	16/8	1	Yes	
606040	AKLW 2	68.0 × 30.0	6/3	1	Yes	Master gauge for holes HAN 24 B attachment housing

Unit corresponds to the number of required rubber modules type VK or VG

# Cable fittings and accessories

## Cablefix Vario

### Feed-through for all prefabricated cables and wires with connectors



#### Application

- Electrotechnology, pneumatics, hydraulics, robotics, general machine and plant construction

#### Properties

- Feed through and terminal frames from high-quality solid material
- Aluminium or polyamide GF50
- High flexibility in the application
- Additional mounting to existing installation easily possible
- Even pressure effect on the feed through round material yields good strain relief and sealing
- Unneeded holes in the module can simply sealed with blank plugs
- Compact design i.e. space-saving
- 2 module sizes with slot and suspension principle
- Very good weatherproof resistance
- Resistant to UV radiation, ozone, oils, fuels, acids, bases, solvents and sea water

Part-No.	Type	Clamping range D mm	Number of holes	Diameter mm	Length mm	Height mm	suitable for Part-No.	PU piece
<b>Rubber module, material TPE</b>								
606150	VK0	0.0 – 0.0 mm	0		40	20		1
606151	VK4	4.0 – 4.5 mm	14		40	20		1
606152	VK5	4.5 – 5.5 mm	8		40	20		1
606153	VK6	5.5 – 6.5 mm	8		40	20		1
606154	VK7	6.5 – 7.5 mm	5		40	20		1
606155	VK8	7.5 – 8.5 mm	5		40	20		1
606156	VK9	8.5 – 9.5 mm	3		40	20		1
606157	VK10	9.5 – 10.5 mm	3		40	20		1
606158	VK12	10.5 – 12.5 mm	2		40	20		1
606159	VK14	12.5 – 14.5 mm	2		40	20		1
606160	VK16	14.5 – 16.5 mm	2		40	20		1
606200	VG0	0.0 – 0.0 mm	0		40	40		1
606201	VG18	16.5 – 18.5 mm	2		40	40		1
606202	VG20	18.5 – 20.5 mm	1		40	40		1
606203	VG22	20.5 – 22.5 mm	1		40	40		1
606204	VG24	22.5 – 24.5 mm	1		40	40		1
606205	VG26	24.5 – 26.5 mm	1		40	40		1
606206	VG28	26.5 – 28.5 mm	1		40	40		1
606207	VG30	28.5 – 30.5 mm	1		40	40		1
606208	VG32	30.5 – 32.5 mm	1		40	40		1
606209	VG34	32.5 – 34.5 mm	1		40	40		1
<b>Matching blank plug, PA6 GF15</b>								
606250	BL4			4	30		606151	1
606251	BL5			5	30		606152	1
606252	BL6			6	30		606153	1
606253	BL7			7	30		606154	1
606254	BL8			8	30		606155	1
606255	BL9			9	30		606156	1
606256	BL10			10	30		606157	1
606257	BL12			12	30		606158	1
606258	BL14			14	30		606159	1
606259	BL16			16	30		606160	1
606260	BL18			18	30		606201	1

# Cable fittings and accessories

## Cablefix flanges

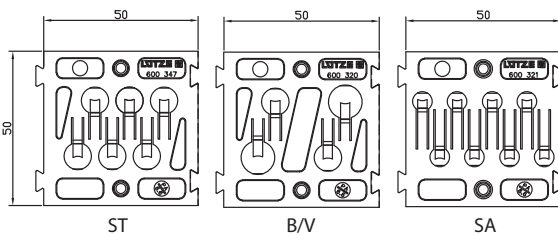

**Application**  
Cablefix flanges are used to introduce cables and wires into a housing. They are used in light to medium-weight machine and plant construction.

### Properties

- With the dovetail guide, the Cablefix flanges can be lined up with each other. This means that various flange combinations can be realized to suit specific requirements.
- Flanges can be used to suit specific requirements
- The integrated strain relief closes automatically when the cables and wires are pushed through.
- An integrated formed rubber part seals off the cables and wires by means of sealing lips.
- For troubleshooting, maintenance or retrofitting, the individual cables can be easily loosened from the spring clamp using a screwdriver and replaced.
- Unused inputs can be closed off using the plugs supplied with the product.
- Resistant to fuels, mineral oils, greases, alkalis
- Halogen- and silicone-free.

### Technical data

Protection class	IP 55 (mounting orientation from below)
Temperature range	-30 °C to +70 °C
Burning behavior	Flange UL 94 V2
max. metal gauge	3 mm
Breakthrough with standard sheet metal hole punch	46 × 46mm

Part-No.	Type	Dimensions (w × h × d) mm	Cut-out W × H mm	Number of cables × cable diameter	Material	PU piece
<b>Cablefix Control cable flange (ST)</b>						
600347	1×ST	50.0 × 50.0 × 11.5	46 × 46	6 × 6.3 – 8.9	Flange: PA 6.6 Seal: TPE Plugs: PA 6 Retaining plates and screws: galvanised steel	5
<b>Cablefix Bus flange (B/V)</b>						
600320	1×B/V	50.0 × 50.0 × 11.5	46 × 46	2 × 6.1 - 8.8 + 2 × 7.8 - 10.7 mm	Flange: PA 6.6 Seal: TPE Plugs: PA 6 Retaining plates and screws: galvanised steel	5
<b>Cablefix Sensor/Actuator flange (S/A)</b>						
600321	1×S/A	50.0 × 50.0 × 11.5	46 × 46	8 × 3.8 - 6.3 mm	Flange: PA 6.6 Seal: TPE Plugs: PA 6 Retaining plates and screws: galvanised steel	5

**Note:**  
50 mm must be allotted for each flange mounted side by side.

# Cable fittings and accessories

## Plastic fittings TOP-T-P, metric version



### Properties

- – metric –
- Cable fitting with hexagon base
- Strain relief and seal

### Technical data

Protection class IP 68 to 5 bar

### Construction

- Material Polyamide PA 6.6-V-2
- Color grey RAL 7001  
black RAL 9005
- Gasket Neoprene

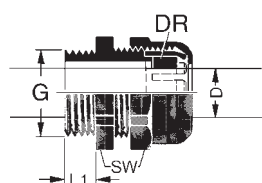

Part-No.	Type	G	Approvals	Clamping range D mm	SW mm	L 1 mm	weight approx. kg/100 piece	PU piece
<b>TOP-T-P metric grey RAL 7001</b>								
600790	TOP-T-P M 12×1,5	M 12×1.5	UR	2.0 – 6.5 mm	15	8.0	0.32	100
600680	TOP-T-P M 16×1,5	M 16×1.5	UR	4.0 – 10.0 mm	20	8.0	0.57	100
600681	TOP-T-P M 20×1,5	M 20×1.5	UL	6.0 – 12.0 mm	24	9.0	0.96	100
600682	TOP-T-P M 25×1,5	M 25×1.5	UL	9.0 – 16.0 mm	28	11.0	1.55	50
600683	TOP-T-P M 32×1,5	M 32×1.5	UL	11.0 – 21.0 mm	36	11.0	2.65	25
600791	TOP-T-P M 40×1,5	M 40×1.5	UL	16.0 – 28.0 mm	46	11.0	4.34	10
600792	TOP-T-P M 50×1,5	M 50×1.5	UR, UL	27.0 – 35.0 mm	55	12.0	6.80	5
600684	TOP-T-P M 63×1,5	M 63×1.5	UR, UL	32.0 – 42.0 mm	68	12.0	9.60	5
<b>TOP-T-P metric black RAL 9005</b>								
600840	TOP-T-P M 12×1,5	M 12×1.5	UR	2.0 – 6.5 mm	15	8.0	0.32	100
600841	TOP-T-P M 16×1,5	M 16×1.5	UR	4.0 – 10.0 mm	20	8.0	0.57	100
600842	TOP-T-P M 20×1,5	M 20×1.5	UL	6.0 – 12.0 mm	24	9.0	0.96	100
600843	TOP-T-P M 25×1,5	M 25×1.5	UL	9.0 – 16.0 mm	28	11.0	1.55	50
600844	TOP-T-P M 32×1,5	M 32×1.5	UL	11.0 – 21.0 mm	36	11.0	2.65	25
600845	TOP-T-P M 40×1,5	M 40×1.5	UL	16.0 – 28.0 mm	46	11.0	4.40	10
600846	TOP-T-P M 50×1,5	M 50×1.5	UL	21.0 – 34.5 mm	55	13.0	7.37	5
600847	TOP-T-P M 63×1,5	M 63×1.5	–	30.0 – 44.5 mm	65	17.0	10.26	5

# Cable fittings and accessories

## Plastic fittings TOP-T-P, PG version



### Properties

- – PG –
- Cable fitting with hexagon base
- Strain relief and seal

### Technical data

Protection class IP 68 to 5 bar

### Construction

- Material polyamide PA 6.6-V-2
- Color Grey RAL 7001 and Black RAL 9005
- Gasket Neoprene

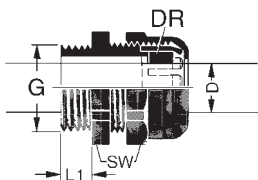

Part-No.	Type	G	Approvals	Clamping range D mm	SW mm	L 1 mm	weight approx. kg/100 piece	PU piece
<b>TOP-T-P PG grey RAL 7001</b>								
600660	TOP-T-P PG 7	PG 7		3.0 – 6.5 mm	15	8.0	0.33	100
600661	TOP-T-P PG 9	PG 9		4.0 – 8.0 mm	19	8.0	0.52	100
600662	TOP-T-P PG 11	PG 11	UR	5.0 – 10.0 mm	22	8.0	0.87	100
600663	TOP-T-P PG 13,5	PG 13.5	UL	6.0 – 12.0 mm	24	9.0	0.96	100
600664	TOP-T-P PG 16	PG 16	UL	10.0 – 14.0 mm	27	10.0	1.37	50
600665	TOP-T-P PG 21	PG 21	UL	13.0 – 18.0 mm	33	11.0	2.04	25
600666	TOP-T-P PG 29	PG 29	UL	18.0 – 25.0 mm	42	11.0	3.88	25
600667	TOP-T-P PG 36	PG 36	UL	22.0 – 32.0 mm	53	13.0	6.90	10
600668	TOP-T-P PG 42	PG 42	UL	30.0 – 38.0 mm	60	13.0	8.80	5
600669	TOP-T-P PG 48	PG 48	UL	34.0 – 44.0 mm	65	14.0	9.79	5
<b>TOP-T-P PG black RAL 7005</b>								
600860	TOP-T-P PG 7	PG 7		3.0 – 6.5 mm	15	8.0	0.33	100
600861	TOP-T-P PG 9	PG 9		4.0 – 8.0 mm	19	8.0	0.52	100
600862	TOP-T-P PG 11	PG 11	UR	5.0 – 10.0 mm	22	8.0	0.87	100
600863	TOP-T-P PG 13,5	PG 13.5	UL	6.0 – 12.0 mm	24	9.0	0.96	50
600864	TOP-T-P PG 16	PG 16	UL	10.0 – 14.0 mm	27	10.0	1.37	50
600865	TOP-T-P PG 21	PG 21	UL	13.0 – 18.0 mm	33	11.0	2.04	50
600866	TOP-T-P PG 29	PG 29	UL	18.0 – 25.0 mm	42	11.0	3.98	25
600867	TOP-T-P PG 36	PG 36	UL	22.0 – 34.0 mm	55	13.0	6.90	10
600868	TOP-T-P PG 42	PG 42	UL	30.0 – 38.0 mm	60	13.0	8.80	5
600869	TOP-T-P PG 48	PG 48	UL	34.0 – 44.0 mm	65	14.0	9.79	5

# Cable fittings and accessories

## Plastic fitting TOP-TR-P

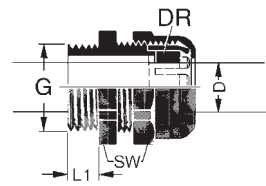

### Properties

- Cable fitting with hexagon base
- Strain relief and gasket
- Reduced sealing insert
- Reduced clamping range

### Technical data

Protection class IP 68 to 5 bar  
 Approvals on request

### Construction

- Material Polyamide PA 6-V-2
- Color grey RAL 7001  
other colors upon request
- Gasket NBR

Part-No.	Type	G	Approvals	Clamping range D mm	SW mm	L 1 mm	weight approx. kg/100 piece	PU piece
<b>TOP-TR-P metric</b>								
600690	TOP-TR-P M 16×1,5	M 16×1.5	on request	2.0 – 7.0 mm	20	8.0	0.62	100
600691	TOP-TR-P M 20×1,5	M 20×1.5	on request	4.0 – 10.0 mm	24	9.0	1.34	100
600692	TOP-TR-P M 25×1,5	M 25×1.5	on request	5.0 – 14.0 mm	28	11.0	1.63	50
600693	TOP-TR-P M 32×1,5	M 32×1.5	on request	8.0 – 18.0 mm	36	11.0	2.72	25



# Cable fittings and accessories

## Plastic accessory locknut GK, metric version



### Properties

- – metric –
- Counter nut, hexagonal, with metric thread according to DIN 46320

### Construction

- Material Polyamide 6 GF 30
- Color grey RAL 7001  
black RAL 9005  
other color upon request

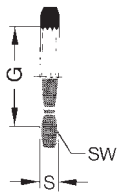

Part-No.	Type	G	SW mm	S mm	weight approx. kg/100 piece	PU piece
<b>GK metric grey RAL 7001</b>						
600398	GK M 12×1,5	M 12×1.5	17	5.0	0.10	100
600391	GK M 16×1,5	M 16×1.5	22	5.0	0.16	100
600392	GK M 20×1,5	M 20×1.5	26	6.0	0.23	100
600393	GK M 25×1,5	M 25×1.5	32	6.0	0.28	100
600394	GK M 32×1,5	M 32×1.5	41	7.0	0.41	100
600395	GK M 40×1,5	M 40×1.5	50	7.0	0.67	50
600396	GK M 50×1,5	M 50×1.5	60	8.0	1.14	50
600698	GK M 63×1,5	M 63×1.5	75	8.0	1.95	50
<b>GK metric black RAL 9005</b>						
600850	GK M 12×1,5	M 12×1.5	17	5.0	0.10	100
600851	GK M 16×1,5	M 16×1.5	22	5.0	0.14	100
600852	GK M 20×1,5	M 20×1.5	26	6.0	0.22	100
600853	GK M 25×1,5	M 25×1.5	32	6.0	0.26	100
600854	GK M 32×1,5	M 32×1.5	41	7.0	0.38	100
600855	GK M 40×1,5	M 40×1.5	50	7.0	0.63	50
600856	GK M 50×1,5	M 50×1.5	60	8.0	1.14	50
600857	GK M 63×1,5	M 63×1.5	75	8.0	1.78	50

# Cable fittings and accessories

## Plastic accessory locknut GK, PG version



### Properties

- – PG –
- Counter nut, hexagonal, with armour threads according to DIN 46320.

### Construction

- Material Polyamide 6 GF 30
- Color grey RAL 7001  
black RAL 9005  
other colors available on request

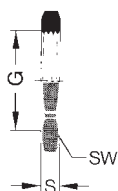

Part-No.	Type	G	SW mm	S mm	weight approx. kg/100 piece	PU piece
<b>GK PG grey RAL 7001</b>						
600430	GK PG 7	PG 7	19	5.0	0.13	100
600431	GK PG 9	PG 9	22	5.0	0.14	100
600432	GK PG 11	PG 11	24	5.0	0.15	100
600433	GK PG 13,5	PG 13,5	27	6.0	0.24	100
600434	GK PG 16	PG 16	30	6.0	0.31	100
600435	GK PG 21	PG 21	36	7.0	0.45	100
600436	GK PG 29	PG 29	46	7.0	0.68	50
600437	GK PG 36	PG 36	60	8.0	1.47	50
600438	GK PG 42	PG 42	65	8.0	1.53	50
600439	GK PG 48	PG 48	70	8.0	1.71	50
<b>GK PG black RAL 9005</b>						
600830	GK SW PG 7	PG 7	19	5.0	0.13	100
600831	GK SW PG 9	PG 9	22	5.0	0.14	100
600832	GK SW PG 11	PG 11	24	5.0	0.15	100
600833	GK SW PG 13,5	PG 13,5	27	6.0	0.24	100
600834	GK SW PG 16	PG 16	30	6.0	0.31	100
600835	GK SW PG 21	PG 21	36	7.0	0.45	100
600836	GK SW PG 29	PG 29	46	7.0	0.68	100
600837	GK SW PG 36	PG 36	60	8.0	1.47	50
600838	GK SW PG 42	PG 42	65	8.0	1.53	50
600839	GK SW PG 48	PG 48	70	8.0	1.71	50

# Cable fittings and accessories

## Plastic accessory reducing ring RR, metric

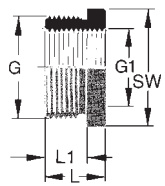

### Properties

- **-metric-**
- Reducing ring from plastic with large outer thread and small inner thread

### Construction

- Material Polyamide PA 6 GF 30
- Color Grey RAL 7035
- other colors upon request

Part-No.	Type	G	G1	SW mm	L mm	L 1 mm	weight approx. kg/100 piece	PU piece
<b>RR-PA metric</b>								
600550	RR-PA M 20/M 12	M 20×1.5	M 12×1.5	24	12.0	8.0	0.39	100
600551	RR-PA M 20/M 16	M 20×1.5	M 16×1.5	24	12.0	8.0	0.26	100
600552	RR-PA M 25/M 12	M 25×1.5	M 12×1.5	29	14.0	8.0	0.70	100
600553	RR-PA M 25/M 16	M 25×1.5	M 16×1.5	29	14.0	8.0	0.67	100
600554	RR-PA M 25/M 20	M 25×1.5	M 20×1.5	29	14.0	8.0	0.50	100
600555	RR-PA M 32/M 12	M 32×1.5	M 12×1.5	36	16.0	10.0	1.06	50
600556	RR-PA M 32/M 16	M 32×1.5	M 16×1.5	36	16.0	10.0	1.06	50
600557	RR-PA M 32/M 20	M 32×1.5	M 20×1.5	36	16.0	10.0	1.20	50
600558	RR-PA M 32/M 25	M 32×1.5	M 25×1.5	36	16.0	10.0	0.88	25
600559	RR-PA M 40/M 16	M 40×1.5	M 16×1.5	46	16.0	10.0	1.59	25
600560	RR-PA M 40/M 20	M 40×1.5	M 20×1.5	46	16.0	10.0	1.68	25
600561	RR-PA M 40/M 25	M 40×1.5	M 25×1.5	46	16.0	10.0	1.36	25
600562	RR-PA M 40/M 32	M 40×1.5	M 32×1.5	46	16.0	10.0	1.35	25
600563	RR-PA M 50/M 20	M 50×1.5	M 20×1.5	55	17.0	12.0	2.15	25
600564	RR-PA M 50/M 25	M 50×1.5	M 25×1.5	55	17.0	12.0	2.16	25
600565	RR-PA M 50/M 32	M 50×1.5	M 32×1.5	55	17.0	12.0	2.06	25
600566	RR-PA M 50/M 40	M 50×1.5	M 40×1.5	55	17.0	12.0	1.97	25
600567	RR-PA M 63/M 25	M 63×1.5	M 25×1.5	68	18.0	12.0	2.65	25
600568	RR-PA M 63/M 32	M 63×1.5	M 32×1.5	68	18.0	12.0	2.95	25
600569	RR-PA M 63/M 40	M 63×1.5	M 40×1.5	68	18.0	12.0	3.08	25
600570	RR-PA M 63/M 50	M 63×1.5	M 50×1.5	68	18.0	12.0	3.05	25

# Cable fittings and accessories

## Plastic accessory Blank plug BL



### Properties

- Blank plug according to DIN 46320

### Construction

- Material Polyamide PA 6 or polystyrene SB
- Color grey RAL 7035
- other colors upon request

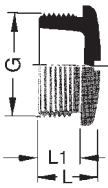

Part-No.	Type	G	L mm	L 1 mm	weight approx. kg/100 piece	PU piece
<b>BL metric PA</b>						
600870	BL M 12	M 12×1.5	9.0	6.0	0.05	100
600871	BL M 16	M 16×1.5	10.0	6.0	0.09	100
600872	BL M 20	M 20×1.5	10.0	6.0	0.19	100
600873	BL M 25	M 25×1.5	11.5	7.0	0.20	100
600874	BL M 32	M 32×1.5	12.5	8.0	0.48	100
600875	BL M 40	M 40×1.5	12.5	9.0	0.66	50
600876	BL M 50	M 50×1.5	15.0	10.0	1.57	25
600877	BL M 63	M 63×1.5	18.0	12.0	2.26	25
<b>BL PG PA</b>						
601490	BL PG 7	PG 7	8.0	6.0	0.07	100
601491	BL PG 9	PG 9	9.5	6.5	0.13	100
601492	BL PG 11	PG 11	10.0	6.5	0.15	100
601493	BL PG 13,5	PG 13.5	10.0	6.5	0.20	100
601494	BL PG 16	PG 16	10.0	6.5	0.23	100
601495	BL PG 21	PG 21	12.0	8.0	0.40	100
601496	BL PG 29	PG 29	11.5	8.0	0.82	50
601497	BL PG 36	PG 36	14.0	10.0	1.32	25

# Cable fittings and accessories

## Metal fitting TOP-T

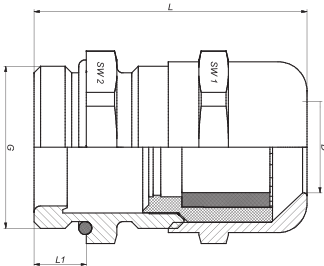

### Properties

- Cable fitting with hexagon base
- Strain relief
- Gasket and O-Ring

### Technical data

Protection class IP 68 to 5 bar

### Construction

- Material Brass nickel-plated
- Gasket Neoprene
- O-ring (OR) Perbunan®

Part-No.	Type	G	Clamping range D mm	SW 1 = across flats mm	SW 2 = across flats mm	L 1 mm	L mm	weight approx. kg/100 piece	PU piece
<b>TOP-T metric</b>									
600701	TOP-T M 12×1,5	M 12×1,5	3.0 – 6.5	14	14	5.0	25.0	1.12	100
600760	TOP-T M 16×1,5	M 16×1,5	5.5 – 10.0	17	17	5.5	27.5	1.55	100
600761	TOP-T M 20×1,5	M 20×1,5	8.0 – 13.0	22	22	6.0	30.0	2.72	50
600762	TOP-T M 25×1,5	M 25×1,5	11.0 – 18.0	30	30	7.0	36.0	5.70	25
600763	TOP-T M 32×1,5	M 32×1,5	15.0 – 21.0	34	34	8.0	38.0	7.41	10
600702	TOP-T M 40×1,5	M 40×1,5	19.0 – 27.0	44	44	8.0	42.0	16.53	10
600703	TOP-T M 50×1,5	M 50×1,5	26.0 – 35.0	54	54	9.0	52.0	33.80	5
600704	TOP-T M 63×1,5	M 63×1,5	39.0 – 48.0	66	66	10.0	54.0	42.50	5
<b>TOP-T PG</b>									
600710	TOP-T PG 7	PG 7	3.0 – 6.5	14	14	5.0	24.0	1.13	100
600711	TOP-T PG 9	PG 9	5.5 – 10.0	17	17	6.0	28.0	1.50	100
600712	TOP-T PG 11	PG 11	5.5 – 10.0	20	20	6.0	32.0	3.12	50
600713	TOP-T PG 13,5	PG 13,5	8.0 – 13.0	22	22	6.5	31.0	2.78	50
600714	TOP-T PG 16	PG 16	8.0 – 14.0	24	24	6.5	31.6	3.34	50
600715	TOP-T PG 21	PG 21	11.0 – 18.0	30	30	7.0	36.5	6.20	50
600716	TOP-T PG 29	PG 29	19.0 – 27.0	40	40	8.0	45.0	11.00	25
600717	TOP-T PG 36	PG 36	26.0 – 35.0	50	50	9.0	54.5	18.82	10
600718	TOP-T PG 42	PG 42	26.0 – 35.0	57	57	10.0	55.0	31.58	5
600719	TOP-T PG 48	PG 48	39.0 – 48.0	66	66	10.0	57.0	29.00	5

# Cable fittings and accessories

## Metal fitting TOP-TR

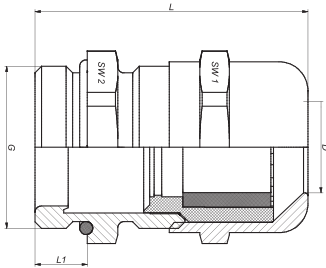

### Properties

- Cable fitting with hexagon base
- Strain relief
- Gasket and O-Ring
- Reduced sealing insert
- Reduced Clamping range

### Technical data

Protection class IP 68 to 5 bar

### Construction

- Material Brass nickel-plated
- Gasket Neoprene
- O-ring (OR) Perbunan®

Part-No.	Type	G	Clamping range D mm	SW 1 = across flats mm	SW 2 = across flats mm	L 1 mm	L mm	weight approx. kg/100 piece	PU piece
<b>TOP-TR metric</b>									
600705	TOP-TR M 12×1,5	M 12×1.5	2.0 – 5.0	14	14	5.0	25.0	1.22	100
600780	TOP-TR M 16×1,5	M 16×1.5	3.0 – 8.0	17	17	5.5	27.5	1.50	100
600781	TOP-TR M 20×1,5	M 20×1.5	6.0 – 12.0	22	22	6.0	30.0	2.73	50
600782	TOP-TR M 25×1,5	M 25×1.5	8.0 – 15.0	30	30	7.0	36.0	5.80	25
600783	TOP-TR M 32×1,5	M 32×1.5	13.0 – 19.0	34	34	8.0	38.0	7.40	10
600706	TOP-TR M 40×1,5	M 40×1.5	16.0 – 23.0	44	44	8.0	42.0	16.72	10
600707	TOP-TR M 50×1,5	M 50×1.5	21.0 – 29.0	54	54	9.0	52.0	33.80	5
600708	TOP-TR M 63×1,5	M 63×1.5	27.0 – 38.0	66	66	10.0	54.0	42.50	5

# Cable fittings and accessories

## Metal fitting with shield termination TOP-T-S-EMV1

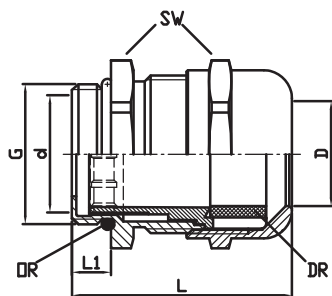

### Properties

- Cable fitting with hexagon base
- Strain relief
- Gasket
- O-ring and EMC compliant shield termination
- For installation, the shield braiding and plastic insert are pressed against fitting base.

### Technical data

Protection class IP 68 to 5 bar

### Construction

- Material Brass nickel-plated
- Gasket Neoprene
- O-ring (OR) Perbunan®

Part-No.	Type	G	Clamping range D mm	SW mm	L 1 mm	d mm	weight approx. kg/100 piece	PU piece
<b>TOP-T-S-EMV1 metric</b>								
600170	TOP-T-S-EMV1 M 12×1,5	M 12×1.5	3.0 – 6.5	14	5.0	5.2	1.21	100
600171	TOP-T-S-EMV1 M 16×1,5	M 16×1.5	5.5 – 10.0	17	5.5	8.2	1.95	100
600172	TOP-T-S-EMV1 M 20×1,5	M 20×1.5	8.0 – 13.0	22	6.0	11.5	3.19	50
600173	TOP-T-S-EMV1 M 25×1,5	M 25×1.5	11.0 – 18.0	30	7.0	15.2	5.95	25
600174	TOP-T-S-EMV1 M 32×1,5	M 32×1.5	15.0 – 21.0	34	8.0	18.0	8.76	10
600175	TOP-T-S-EMV1 M 40×1,5	M 40×1.5	19.0 – 27.0	44	8.0	23.0	20.40	10
600176	TOP-T-S-EMV1 M 50×1,5	M 50×1.5	26.0 – 35.0	55	9.0	31.0	36.20	5
600177	TOP-T-S-EMV1 M 63×1,5	M 63×1.5	39.0 – 48.0	66	10.0	31.0	46.50	5
<b>TOP-T-S-EMV1 PG</b>								
600520	TOP-T-S-EMV1 PG 7	PG 7	3.0 – 6.5	14	5.0	5.0	1.20	100
600521	TOP-T-S-EMV1 PG 9	PG 9	5.5 – 10.0	17	6.0	7.5	1.70	100
600522	TOP-T-S-EMV1 PG 11	PG 11	5.5 – 10.0	20	6.0	9.5	3.37	50
600523	TOP-T-S-EMV1 PG 13,5	PG 13.5	8.0 – 13.0	22	6.5	11.5	3.10	50
600524	TOP-T-S-EMV1 PG 16	PG 16	8.0 – 14.0	24	6.5	12.0	3.64	50
600525	TOP-T-S-EMV1 PG 21	PG 21	11.0 – 18.0	30	7.0	17.5	5.76	25
600526	TOP-T-S-EMV1 PG 29	PG 29	19.0 – 27.0	40	8.0	25.0	12.00	25
600527	TOP-T-S-EMV1 PG 36	PG 36	24.0 – 32.0	50	9.0	31.5	15.10	10
600528	TOP-T-S-EMV1 PG 42	PG 42	30.0 – 38.0	57	10.0	37.5	21.10	5
600529	TOP-T-S-EMV1 PG 48	PG 48	34.0 – 44.0	64	10.0	43.5	30.00	5

# Cable fittings and accessories

## Metal fitting with shield termination TOP-T-S-EMV2

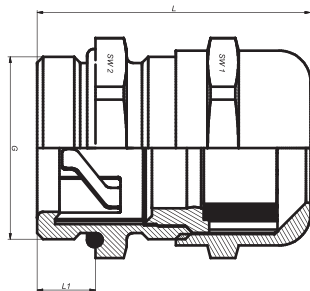

### Properties

- Cable fitting with hexagon base
- Strain relief
- Gasket
- O-ring and EMC compliant shield termination
- The braided shield is automatically contacted when mounting the screw connection.

### Technical data

Protection class IP 68 to 5 bar, 30 Min.

### Construction

- Material Brass nickel-plated
- Gasket Neoprene
- O-ring (OR) Perbunan®

Part-No.	Type	G	Clamping range D mm	SW 1 = across flats mm	SW 2 = across flats mm	L 1 mm	L mm	weight approx. kg/100 piece	PU piece
<b>TOP-T-S-EMV2 metric</b>									
600370	TOP-T-S-EMV2 M 12x1,5	M 12x1.5	3.0 – 6.5	14	14	6.0	27.5	1.26	50
600371	TOP-T-S-EMV2 M 16x1,5	M 16x1.5	4.0 – 8.0	17	18	7.0	30.0	1.93	50
600372	TOP-T-S-EMV2 M 20x1,5	M 20x1.5	6.0 – 12.0	22	22	8.0	32.3	2.79	50
600373	TOP-T-S-EMV2 M 25x1,5	M 25x1.5	10.0 – 14.0	24	27	8.0	35.6	4.62	25
600374	TOP-T-S-EMV2 M 32x1,5	M 32x1.5	13.0 – 18.0	30	34	9.0	40.2	8.05	25
600375	TOP-T-S-EMV2 M 40x1,5	M 40x1.5	18.0 – 25.0	40	43	9.0	47.5	15.10	10
600376	TOP-T-S-EMV2 M 50x1,5	M 50x1.5	22.0 – 32.0	50	55	9.0	56.3	28.10	5
600377	TOP-T-S-EMV2 M 63x1,5	M 63x1.5	34.0 – 44.0	64	68	14.0	64.3	45.20	5



# Cable fittings and accessories

## Metal accessory Locknut GMS



### Properties

- Counter nut according to DIN 46320, hexagonal

### Construction

- Material Brass nickel-plated

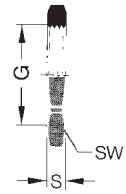

Part-No.	Type	G	SW mm	S mm	weight approx. kg/100 piece	PU piece
<b>GMS metric</b>						
600368	GMS M 12 × 1.5	M 12×1.5	15	2.8	0.20	100
600361	GMS M 16 × 1.5	M 16×1.5	19	2.8	0.27	100
600362	GMS M 20 × 1.5	M 20×1.5	24	3.0	0.48	100
600363	GMS M 25 × 1.5	M 25×1.5	30	3.5	0.90	100
600364	GMS M 32 × 1.5	M 32×1.5	36	4.0	1.08	100
600365	GMS M 40 × 1.5	M 40×1.5	46	5.0	2.40	50
600366	GMS M 50 × 1.5	M 50×1.5	57	5.0	3.25	25
600367	GMS M 63 × 1.5	M 60×1.5	70	6.0	4.62	25
<b>GMS PG</b>						
600420	GMS PG 7	PG 7	15	2.8	0.18	100
600421	GMS PG 9	PG 9	18	2.8	0.23	100
600422	GMS PG 11	PG 11	21	3.0	0.30	100
600423	GMS PG 13.5	PG 13.5	23	3.0	0.36	100
600424	GMS PG 16	PG 16	26	3.0	0.50	100
600425	GMS PG 21	PG 21	32	3.5	0.79	100
600426	GMS PG 29	PG 29	41	4.0	1.30	50
600427	GMS PG 36	PG 36	51	5.0	2.10	50
600428	GMS PG 42	PG 42	60	5.0	3.45	50
600429	GMS PG 48	PG 48	64	5.5	3.39	50

# Cable fittings and accessories

## Metal accessory Locknut GMS EMC



### Properties

- Hexagonal nut for potential equalisation
- With cutting edges for cutting through layers of paint or power coating for optimal contact

### Construction

- Material Brass nickel-plated

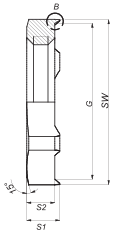

Part-No.	Type	G	SW mm	S1 mm	S2 mm	weight approx. kg/100 piece	PU piece
<b>GMS EMV metric</b>							
600460	GMS EMV M 12 × 1.5	M 12×1.5	15	4.7	2.8	0.26	100
600461	GMS EMV M 16 × 1.5	M 16×1.5	19	4.7	3.0	0.37	100
600462	GMS EMV M 20 × 1.5	M 20×1.5	24	4.7	3.0	0.65	100
600463	GMS EMV M 25 × 1.5	M 25×1.5	30	5.2	3.0	1.06	50
600464	GMS EMV M 32 × 1.5	M 32×1.5	36	5.7	3.5	1.35	50
600465	GMS EMV M 40 × 1.5	M 40×1.5	46	6.5	4.0	2.85	50
600466	GMS EMV M 50 × 1.5	M 50×1.5	60	6.0	5.0	5.46	10
600467	GMS EMV M 63 × 1.5	M 63×1.5	70	6.0	6.0	5.92	10
<b>GMS EMV PG</b>							
600530	GMS EMV PG 7	PG 7	15	4.7	2.8	0.25	100
600531	GMS EMV PG 9	PG 9	18	4.7	2.8	0.33	100
600532	GMS EMV PG 11	PG 11	21	4.7	3.0	0.38	100
600533	GMS EMV PG 13.5	PG 13.5	23	4.7	3.0	0.45	100
600534	GMS EMV PG 16	PG 16	26	4.7	3.0	0.63	100
600535	GMS EMV PG 21	PG 21	32	5.2	3.5	0.98	50
600536	GMS EMV PG 29	PG 29	41	5.7	4.0	1.58	50
600537	GMS EMV PG 36	PG 36	51	6.5	5.0	2.58	50
600538	GMS EMV PG 42	PG 42	60	6.5	5.0	3.12	25
600539	GMS EMC PG 48	PG 48	64	6.5	5.5	3.74	50

# Cable fittings and accessories

## Metal accessory reducing ring RR

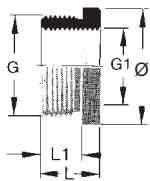

### Properties

- Reducing ring from **metric to metric** or **PG to PG**
- with large outer thread and small inner thread

### Construction

- Material Brass nickel-plated

Part-No.	Type	G	G1	Outer Ø mm	L mm	L 1 mm	weight approx. kg/100 piece	PU piece
<b>RR metric metric/metric</b>								
600220	RR M 16/M 12	M 16×1.5	M 12×1.5	18.0	7.5	5.0	0.54	100
600221	RR M 20/M 12	M 20×1.5	M 12×1.5	24.0	8.5	6.0	1.59	100
600222	RR M 20/M 16	M 20×1.5	M 16×1.5	22.0	9.0	6.0	0.86	100
600223	RR M 25/M 16	M 25×1.5	M 16×1.5	30.0	10.0	7.0	2.76	50
600224	RR M 25/M 20	M 25×1.5	M 20×1.5	27.0	10.0	7.0	1.45	100
600225	RR M 32/M 20	M 32×1.5	M 20×1.5	37.0	11.5	8.0	5.16	50
600226	RR M 32/M 25	M 32×1.5	M 25×1.5	37.0	11.5	8.0	3.45	50
600227	RR M 40/M 25	M 40×1.5	M 25×1.5	43.0	11.5	8.0	7.44	25
600228	RR M 40/M 32	M 40×1.5	M 32×1.5	43.0	11.5	8.0	4.54	25
600229	RR M 50/M 32	M 50×1.5	M 32×1.5	56.0	14.0	10.0	14.58	10
600230	RR M 50/M 40	M 50×1.5	M 40×1.5	56.0	14.0	10.0	9.29	10
600231	RR M 63/M 40	M 63×1.5	M 40×1.5	66.0	14.0	10.0	19.81	10
600232	RR M 63/M 50	M 63×1.5	M 50×1.5	66.0	14.0	10.0	12.35	10
<b>RR PG PG/PG</b>								
600400	RR PG 9/PG 7	PG 9	PG 7	17.0	8.5	6.0	0.45	100
600411	RR PG 11/PG 7	PG 11	PG 7	20.0	8.5	6.0	1.20	100
600401	RR PG 11/PG 9	PG 11	PG 9	20.0	8.5	6.0	0.65	100
600408	RR PG 13.5/PG 9	PG 13.5	PG 9	22.0	9.0	6.5	1.01	100
600402	RR PG 13.5/PG 11	PG 13.5	PG 11	22.0	9.0	6.5	0.47	100
600409	RR PG 16/PG 9	PG 16	PG 9	24.0	9.5	6.5	0.85	100
600410	RR PG 16/PG 11	PG 16	PG 11	24.0	9.5	6.5	1.01	100
600403	RR PG 16/PG 13.5	PG 16	PG 13.5	24.0	9.5	6.5	0.59	100
600413	RR PG 21/PG 11	PG 21	PG 11	30.0	10.0	7.0	2.90	50
600414	RR PG 21/PG 13.5	PG 21	PG 13.5	30.0	10.0	7.0	1.23	50
600404	RR PG 21/PG 16	PG 21	PG 16	30.0	10.0	7.0	1.95	50
600407	RR PG 29/PG 16	PG 29	PG 16	39.0	11.5	8.0	6.42	50
600405	RR PG 29/PG 21	PG 29	PG 21	39.0	11.5	8.0	4.34	50
600412	RR PG 36/PG 21	PG 36	PG 21	50.0	12.5	9.0	11.40	25
600406	RR PG 36/PG 29	PG 36	PG 29	50.0	12.5	9.0	3.42	25
600416	RR PG 42/PG 36	PG 42	PG 36	57.0	14.0	10.0	7.00	10
600417	RR PG 48/PG 36	PG 48	PG 36	64.0	14.0	10.0	12.80	10
600415	RR PG 48/PG 42	PG 48	PG 42	64.0	14.0	10.0	6.40	10

# Cable fittings and accessories

## Metal accessory expansion EW



### Properties

- Expansion from **metric to metric** or **PG to PG**
- with small outer thread and large inner thread

### Construction

- Material Brass nickel-plated

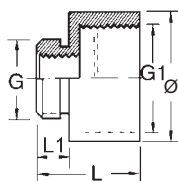

Part-No.	Type	G	G1	Outer Ø mm	L mm	L 1 mm	weight approx. kg/100 piece	PU piece
<b>EW metric metric/metric</b>								
600280	EW M 12/M 16	M 12×1.5	M 16×1.5	18.0	15.5	5.0	0.91	100
600281	EW M 16/M 20	M 16×1.5	M 20×1.5	22.0	17.5	5.0	1.29	100
600282	EW M 20/M 25	M 20×1.5	M 25×1.5	27.0	20.0	6.0	1.98	100
600283	EW M 25/M 32	M 25×1.5	M 32×1.5	34.0	22.5	7.0	3.22	100
600284	EW M 32/M 40	M 32×1.5	M 40×1.5	42.0	24.5	8.0	4.39	50
600285	EW M 40/M 50	M 40×1.5	M 50×1.5	52.0	27.5	8.0	6.43	50
600286	EW M 50/M 63	M 50×1.5	M 63×1.5	66.0	31.0	9.0	12.00	25
<b>EW PG PG/PG</b>								
600500	EW PG 7/PG 9	PG 7	PG 9	17.0	15.0	5.0	0.64	100
600501	EW PG 9/PG 11	PG 9	PG 11	20.0	16.5	6.0	0.82	100
600502	EW PG 11/PG 13.5	PG 9	PG 13.5	22.0	17.5	6.0	1.02	100
600503	EW PG 11/PG 13.5	PG 11	PG 13.5	22.0	17.5	6.0	1.15	100
600504	EW PG 11/PG 16	PG 11	PG 16	24.0	18.5	6.0	1.32	100
600506	EW PG 13.5/PG 16	PG 13.5	PG 16	24.0	19.0	6.5	1.32	100
600507	EW PG 13.5/PG 21	PG 13.5	PG 21	30.0	21.0	6.5	2.26	50
600508	EW PG 16/PG 21	PG 16	PG 21	30.0	21.0	6.5	2.09	50
600510	EW PG 21/PG 29	PG 21	PG 29	39.0	23.0	7.0	3.63	50
600511	EW PG 29/PG 36	PG 29	PG 36	50.0	27.5	8.0	7.30	25
600512	EW PG 36/PG 42	PG 36	PG 42	57.0	31.0	9.0	9.12	10
600513	EW PG 42/PG 48	PG 42	PG 48	64.0	33.0	10.0	14.45	10

# Cable fittings and accessories

## Metal accessory blank plug BLMS



### Properties

- Blank plug according to DIN 46320

### Construction

- Material Brass nickel-plated

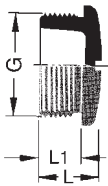

Part-No.	Type	G	L mm	L 1 mm	weight approx. kg/100 piece	PU piece
<b>BLMS metric</b>						
600090	BLMS M 12	M 12×1.5	7.5	5.0	0.38	100
600091	BLMS M 16	M 16×1.5	8.0	5.0	0.55	100
600092	BLMS M 20	M 20×1.5	9.5	6.0	0.98	100
600093	BLMS M 25	M 25×1.5	11.0	7.0	1.56	100
600094	BLMS M 32	M 32×1.5	12.0	8.0	2.50	50
600095	BLMS M 40	M 40×1.5	13.0	8.0	3.90	50
600096	BLMS M 50	M 50×1.5	15.0	9.0	7.90	25
600097	BLMS M 63	M 63×1.5	16.0	10.0	12.00	10
<b>BLMS metr. with O ring</b>						
600201	BLMS M 12	M 12×1.5	7.5	5.0	0.32	100
600202	BLMS M 16	M 16×1.5	8.0	5.0	0.60	100
600203	BLMS M 20	M 20×1.5	9.5	6.0	0.87	100
600204	BLMS M 25	M 25×1.5	11.0	7.0	1.57	100
600205	BLMS M 32	M 32×1.5	12.0	8.0	2.42	50
600206	BLMS M 40	M 40×1.5	13.0	8.0	3.90	50
600207	BLMS M 50	M 50×1.5	15.0	9.0	7.25	25
600208	BLMS M 63	M 63×1.5	16.0	10.0	12.03	10
<b>BLMS PG</b>						
600590	BLMS PG 7	PG 7	8.0	5.0	0.34	100
600591	BLMS PG 9	PG 9	9.0	6.0	0.45	100
600592	BLMS PG 11	PG 11	9.0	6.0	0.71	100
600593	BLMS PG 13.5	PG 13.5	9.5	6.5	0.87	100
600594	BLMS PG 16	PG 16	9.5	6.5	1.10	100
600595	BLMS PG 21	PG 21	11.0	7.0	2.11	50
600596	BLMS PG 29	PG 29	12.0	8.0	3.81	25
600597	BLMS PG 36	PG 36	15.0	9.0	8.10	10

# Cable fittings and accessories

## Plastic and metal accessory multiple sealing insert MFDE



### Application

- For retroactive installation in our cable fittings Type Top T in plastic and brass, if necessary these are to be drilled yourself depending on needs
- PG 11 suitable for M 16  
PG 13.5 suitable for M 20  
PG 16 suitable for M 25  
PG 21 suitable for M 32

### Properties

- Multiple sealing insert for two or more cables in a fitting

### Construction

- Material TPE

Part-No.	Type	Outer Ø mm	Number of cables x Ø mm	weight approx. kg/100 piece	PU piece
<b>MFDE PG</b>					
600626	MFDE PG 9	10.0	2 x 3.0	0.57	100
600627	MFDE PG 9	10.0	4 x 3.0	0.46	100
600541	MFDE PG 9	10.0	0 x 0.0	0.70	100
600628	MFDE PG 11	13.0	2 x 4.0	1.00	100
600629	MFDE PG 11	13.0	2 x 4.5	0.80	100
600635	MFDE PG 11	13.0	3 x 4.0	0.10	100
600636	MFDE PG 11	13.0	3 x 5.0	0.70	100
600542	MFDE PG 11	13.0	0 x 0.0	0.11	100
600638	MFDE PG 13.5	15.0	2 x 4.5	1.32	100
600639	MFDE PG 13.5	15.0	2 x 5.0	1.20	100
600640	MFDE PG 13.5	15.0	2 x 6.0	1.20	100
600637	MFDE PG 13.5	15.0	3 x 4.0	1.40	100
600630	MFDE PG 13.5	15.0	3 x 5.0	1.20	100
600543	MFDE PG 13.5	15.0	0 x 0.0	1.60	100
600641	MFDE PG 16	17.0	2 x 4.0	2.00	100
600644	MFDE PG 16	17.0	2 x 6.0	1.78	100
600631	MFDE PG 16	17.0	3 x 4.0	1.92	100
600643	MFDE PG 16	17.0	3 x 5.0	1.60	100
600646	MFDE PG 16	17.0	4 x 6.0	1.20	100
600633	MFDE PG 16	17.0	5 x 4.0	1.62	100
600544	MFDE PG 16	17.0	0 x 0.0	2.30	100
600645	MFDE PG 16	17.0	3 x 6.0	1.00	100
600647	MFDE PG 16	17.0	3 x 6.5	1.20	100
600642	MFDE PG 16	17.0	4 x 4.0	1.73	100
600632	MFDE PG 16	17.0	4 x 5.0	1.20	100
600648	MFDE PG 21	22.0	2 x 7.0	3.60	100
600651	MFDE PG 21	22.0	2 x 8.0	3.20	100
600653	MFDE PG 21	22.0	2 x 9.0	3.20	100
600649	MFDE PG 21	22.0	3 x 7.0	3.00	100
600652	MFDE PG 21	22.0	3 x 8.0	2.65	100
600634	MFDE PG 21	22.0	4 x 7.0	2.60	100
600545	MFDE PG 21	22.0	0 x 0.0	5.60	100
600656	MFDE PG 29	29.5	5 x 8.5	6.00	100
600654	MFDE PG 29	29.5	6 x 5.0	7.70	100
600655	MFDE PG 29	29.5	8 x 5.0	7.40	100
600546	MFDE PG 29	29.5	0 x 0.0	9.80	100

# Cable fittings and accessories

## Plastic and metal accessory sealing insert ASI DE

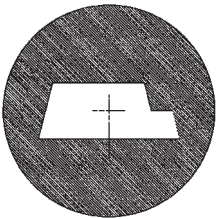

### Application

- For retroactive installation of our cable fittings
- **Cable dimensions:** 4.0 mm × 10.0 mm +/- 0.2 mm
- **Suitable for installation with the following types:**
  - TOP TP PG 13.5
  - TOP TP M 20
  - TOP T PG 13.5
  - TOP T M 20

### Properties

- Seal insert for ASI bus cables

### Construction

- Material TPE

Part-No.	Type	Outer Ø mm	weight approx. kg/100 piece	PU piece
<b>ASI DE</b>				
600120	ASI DE PG 13.5	15.2	0.13	100

# Mounting accessories and tools

## Control panel installation



### Properties

- The developed snap-fit socket with fully-protected wire connections and integrated snap connection enables a simple and quick installation in the control cabinet.

Part-No.	Type	Description	Nominal voltage range	Number of terminations	Voltage V	Color	weight approx. kg/100 piece	PU piece
<b>Socket ST-3/S</b>								
680572	ST-3/S GR	Socket ST -3/S	DC 10A / AC 16A	2	250	grey	6.20	10
680576	ST-3/S	Socket ST -3/S	DC 10A / AC 16A	2	250	yellow	6.20	10
<b>Socket ST-3/A</b>								
680571	ST-3/A GR	Socket ST-3/A with switch indicator (green glow lamp)	DC 10A / AC 16A	2	250	grey	6.20	10
<b>Socket ST-3/F</b>								
680573	ST-3/F	Socket ST-3/F French construction	DC 10A / AC 16A	2	250	grey	6.30	10
<b>Adapter</b>								
680574	ST3/SEV-TYP 13/23	Adapter ST3/SEV Type 13, suitable for ST-3/S, ST-3/A, ST-3/4.	DC 10A / AC 16A	2	250	grey	6.00	1



# Mounting accessories and tools

## Cable tie



### Application

- Cable ties – fast and simple installation
- For the bundling, binding and attaching of cables, conductors, braids, wires and conduit. **Non-detachable!**

### Technical data

Temperature range                      -10 °C to +85 °C

### Construction

- Material Polyamide KSN = mold-resistant; KSS = UV-resistant
- Color natural, black

Part-No.	Type	Color	Width mm	bundling range to approx. ... mm Ø	weight approx. kg/100 piece	PU piece
<b>cable tie KSN</b>						
680100	KSN 1	natural	2.4	18	0.30	1000
680101	KSN 2	natural	4.5	44	1.00	1000
680102	KSN 3	natural	5.0	102	3.00	1000
<b>Cable tie KSS</b>						
680105	KSS 1	black	2.5	18	0.40	1000
680106	KSS 2	black	5.0	44	1.20	1000
680107	KSS 3	black	5.0	102	5.50	1000
680108	KSS 4	black	2.5	55	0.80	1000

# Labelling system

## Identification of hook-up wires and cables



### Technical data

Temperature range -30 °C to +80 °C  
Stability UV-stable and non-yellowing

### Construction

- Material Polypropylene
- Coverage cap: Polystyrene

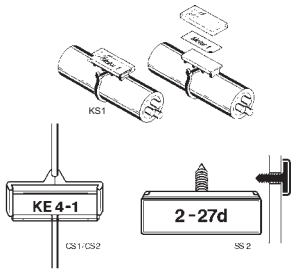

Part-No.	Type	Description	Dimensions mm	weight approx. kg/100 piece	PU piece
<b>Clip markers CS 1/CS 2</b>					
680418	CS 1	For labelling of devices and supply cables after the wiring. Termination area 0.75 to 4.0 mm clip-on markers are supplied with labelling sheets. Labelling sheets for laser printer see system for laser printer labelling.	28 × 11	0.10	500
680419	CS 2	For labelling of devices and supply cables after the wiring. Termination area 0.75 to 4.0 mm clip-on markers are supplied with labelling sheets. Labelling sheets for laser printer see system for laser printer labelling.	39 × 15.5	0.30	500
<b>Cable marker KS 1</b>					
681310	KS 1	The cable marker <b>KS 1</b> is designed for the labelling of cables, wires and conduits, pipes etc. in raw, damp and dusty environments. The label with the information is embedded in the cable marker and thus fully protected. The marker is attached using cable ties. (not included in the scope of delivery, when ordering the cable tie, selected the appropriate size.) Cable markers are supplied with labelling sheets. Labelling sheets for laser printer see system for laser printer labelling.	34 × 16	0.30	500
<b>Plug-in marker SS 2</b>					
680424	SS 2	For the labelling of devices on the mounting panel. Hole 4 mm. Pressing in of the plug-in marker. Securely locked in by plastic lugs. Plug-in markers are supplied with labelling sheets. labelling sheets see system for laser printer labelling.	32 × 12	0.30	500
<b>Labels on sheets, endless form</b>					
680428	BS-CS 1	Labelling sheet for CS 1	20.5 × 9.0		360
680429	BS-CS 2	Labelling sheet for CS 2	30.3 × 12.8		168

# Labelling system

## Laser labels

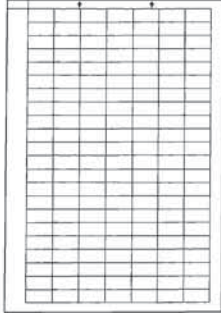

### Application

- For the printing with laser printer
- The high-contrast printing and the high resolution of laser printers set quality standards
- The available border and the appropriate row and column spacing enable the optimal utilisation of the entire labelling field of the self-adhesive labels
- Very high resistance to external influences and very high ageing resistance of the printed image.

### Construction

- Material Polyester white matte
- Dimension 0.05 mm

Part-No.	Type	Description	Dimensions mm	Label/Sheet
<b>Laser labels</b>				
681316	BSL-CS 1	Labels for clip on markers CS 1	8.5 × 20	270
681318	BSL-SS 2	Labels for identification of hook-up wires and cables CS 2, SS 2 and KS 1.	12 × 29	138
<b>Self-adhesive laser labels</b>				
681032	LEB 0920 PW	Labels suitable for: marker holder BZT 0920 MINICOMPACT DIOFACE valve plug all devices with standard marker	9 × 20	270
681033	LEB 0615 PW	Labels suitable for: marker holder BZT 0720 MINICOMPACT modules 12.5 mm Actuator sensor boxes DIOPLEX	6.35 × 15.24	528
681034	LEB 0415 PW	Labels suitable for: marker holder BZT 0411 MICROCOMPACT modules 6.2 mm	4.23 × 15.24	792

# Labelling system

## Marker strips



### Application

- Marker strips flexible and self-adhesive
- For the labelling of cable channels, control panels, operator panels ...
- The labelled inserts are protected by a transparent film
- Transparent hard film with exchangeable case strips for self-labelling
- Can be cut to any desired length
- Film and labelling strips are supplied separately

Part-No.	Type	Description	PU piece
<b>Marker strip BS</b>			
680420	BS	Width × Length: 21.5 mm × 1000 mm max. Labelling surface area: 18.0 mm × 1000 mm	10

## 10. EMC accessories

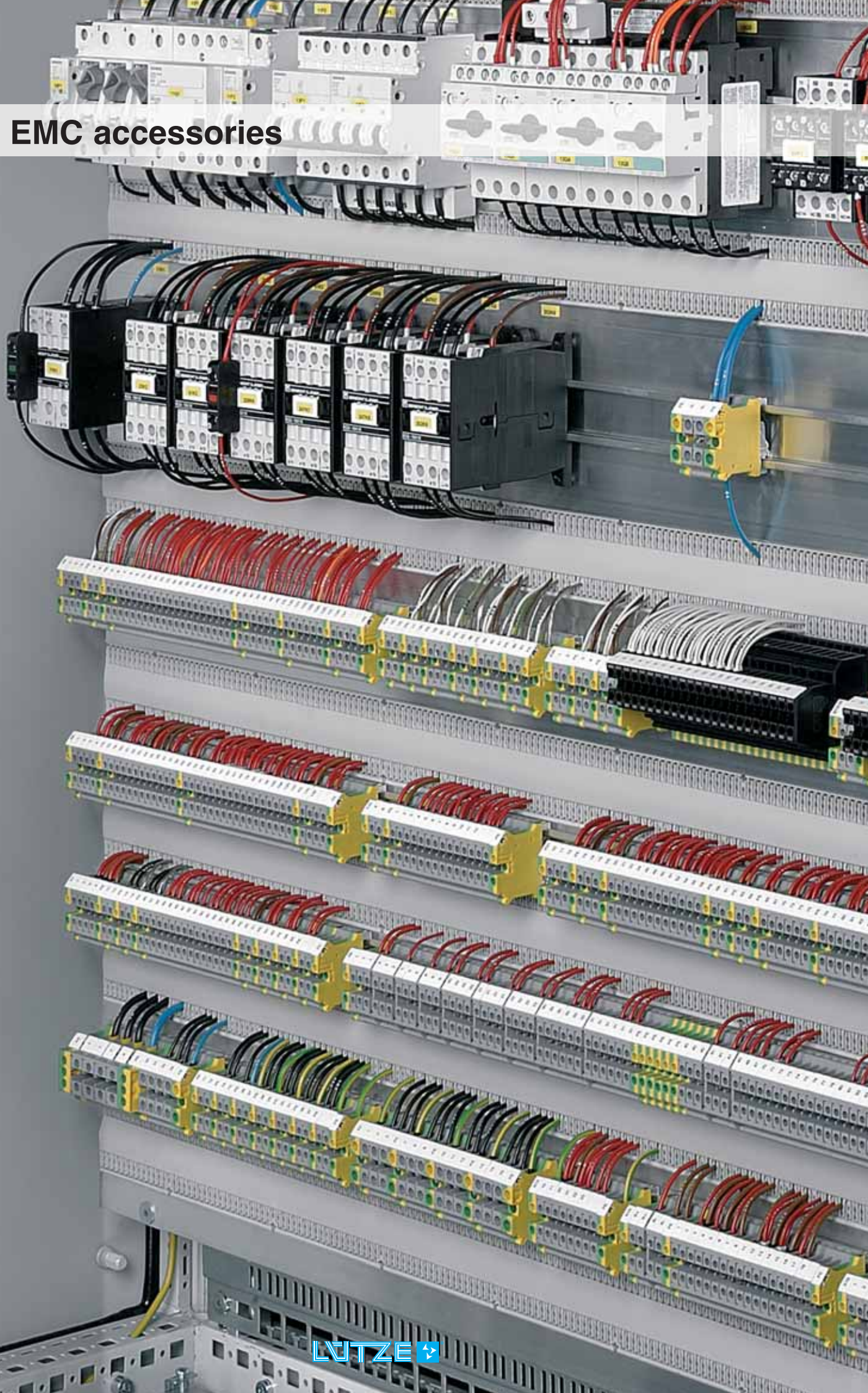

## 10. EMC accessories



<b>EMC shield rails and accessories</b>	<b>Page</b> 10.3 - 10.6
<b>EMC shield clamps and accessories</b>	10.7 - 10.10
<b>Earthing strips</b>	10.11 - 10.12
<b>Cable clips</b>	10.13

**More Informations about cabinet  
wiring with LÜTZE LSC AirSTREAM:**  
[www.luetze.com](http://www.luetze.com) and  
<http://www.youtube.com/Luetzesolutions>



# EMC accessories - EMC shield rail

## EMC shield rail

EMC shield rail with cable clamping options for a wide variety of shield clamps



### Dimensions

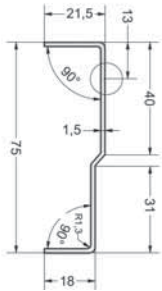
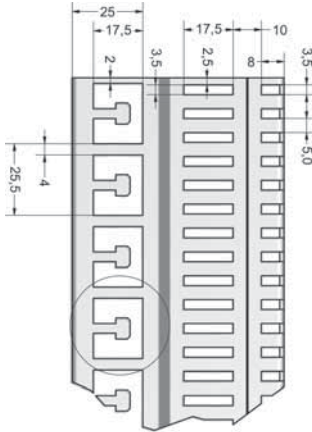

Description	Part-No.	Type	PU
EMC shield rail	346812	EMVS 03-46812	1

Technical data		346812	
Number of shield points		46	
Length		1173.00 mm	
Height		75.0 mm	
Width		21.5 mm	
Weight (kg/piece)		1.169	

General		ST37-2-G	
Material		ST37-2-G	
Surface		burr-free	
Color		sendzimier-zinc-plated 20-25 µm	
Storage temperature range		-30 °C – 90 °C	
Operation temperature range		-5 °C – 80 °C	

usable shield clamps	for cable Ø mm	Type	Article number	PU
Shield clamp	0–12	EMVSK 12	330089.0100	100
spring shield clamp	12–20	EMVFSK 1	330071.0010	10
spring shield clamp	20–30	EMVFSK 2	330072.0010	10
spring shield clamp	30–50	EMVFSK 3	330073.0010	10
Metal tie wrap	250 mm length	KSE	330060.0010	10
as clamping option	for cable Ø mm	Type	Article number	PU
Cable clamp	8–12	KS 0	331000.0010	10
Cable clamp	12–16	KS 1	331001.0010	10
Cable clamp	16–22	KS 2	331002.0010	10
Cable clamp	34–40	KS 3	331003.0010	10
Cable clamp	52–58	KS 4	331004.0010	10

### Comments

Mounting hole, diam. 8.5 mm, is made by the user.

Shield rails are mounted via spacing rollers DR 20×18/8.5 Article no. 330930.0100

possible screw M8×30, Article no. 331050.0100

# EMC accessories - Mounting bracket

## Mounting bracket

Mounting bracket for fastening the EMC rail in the control cabinet



### Dimensions

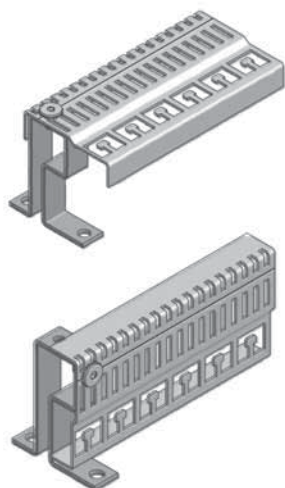
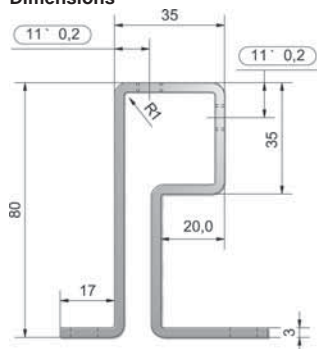

Description	Part-No.	Type	PU
Mounting bracket	346860.0002	HW-EMVS 03	2
<b>Technical data</b>			
	<b>346860.0002</b>		
Dimensions (w × h × d)	18.0 × 80.0 × 65.0 mm		
Material thickness	3 mm		
Thread	2×M8		
Hole diameter	2× 8.5 mm		
weight approx.	9.80 kg/100 piece		
<b>General</b>			
Material	S235JR (ST37-2)		
Surface	smooth		
Color	Punched edges bare/bright galvanised		
Storage temperature range	-30 °C – 90 °C		
Operation temperature range	-5 °C – 80 °C		

**Comments**  
suitable for shield rail 346813



# EMC accessories - EMC shield rail

## EMC shield rail

EMC shield rail with cable clamping options for a wide variety of shield clamps



### Dimensions

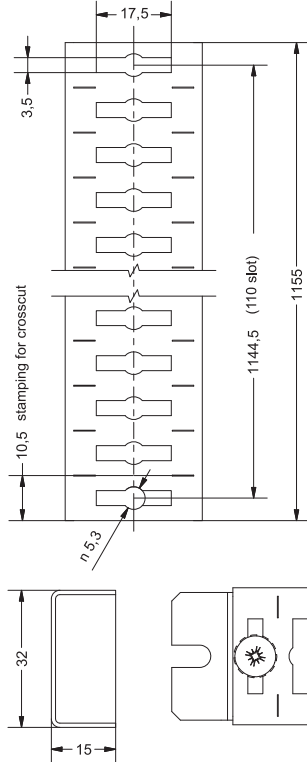

Description	Part-No.	Type	PU
EMC shield rail	346813	EMVS 04-55813	1
<b>Technical data</b>		<b>346813</b>	
Number of shield points		max. 55	
Dimensions (w × h × d)		32.0 × 15.0 × 1155.0 mm	
weight approx.		0.47 kg/100 piece	
Hole diameter		5.3 mm	
<b>General</b>			
Material		Sheet steel	
Surface		galvanised	
Color		Punched edges bare/natural	
Storage temperature range		-30 °C – 90 °C	
Operation temperature range		-5 °C – 80 °C	
<b>Accessories</b>		<b>Article number</b>	<b>Type</b>
Bracket	346814.0010	HW EMVS-04	10

# EMC accessories - Bracket

## Bracket

### Retaining bracket for fastening the EMC rail



#### Dimensions

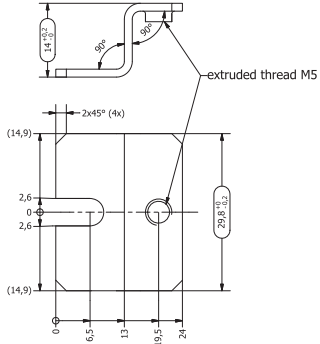

Description	Part-No.	Type	PU
Bracket	346814.0010	HW-EMVS 04	10
<b>Technical data</b>			
	<b>346814.0010</b>		
Dimensions (w × h × d)	29.8 × 14.0 × 24.0 mm		
Material thickness	1.5 mm		
Thread	M5		
Hole diameter	-		
weight approx.	- kg/100 piece		
<b>General</b>			
Material	V2A		
Surface	smooth		
Color	Punched edges bare/natural		
Storage temperature range	-30 °C – 90 °C		
Operation temperature range	-5 °C – 80 °C		
<b>Comments</b>			
suitable for shield rail 346813			



# EMC accessories - Spring shield clamp

## Spring shield clamp Shield connection for large-diameter cables



Description	Part-No.	Type	PU
<b>Spring shield clamp</b>			
	330071.0010	EMVFSK 1	10
	330072.0010	EMVFSK 2	10
	330073.0010	EMVFSK 3	10
<b>Technical data</b>	<b>330071.0010</b>	<b>330072.0010</b>	<b>330073.0010</b>
For cable diameter	12 – 20 mm	20 – 30 mm	30 – 50 mm
Length	42.00 mm	55.00 mm	74.00 mm
weight approx.	0.30 kg/100 piece	0.50 kg/100 piece	0.70 kg/100 piece
Tensile strength (N/mm <sup>2</sup> )		1000–1200	
<b>General</b>			
Material	Spring steel		
Color	bare/stainless		
Operation temperature range	0 °C – 60 °C		

### Dimensions

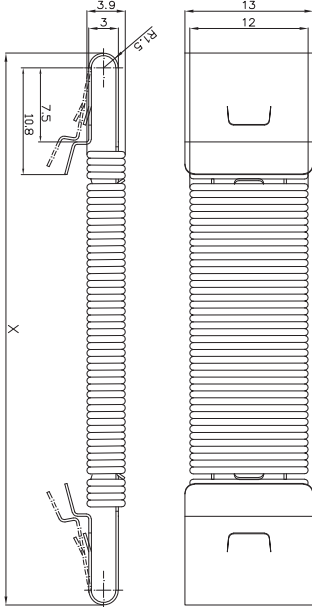

# EMC accessories - Snap-on element

## Snap-on element for snapping onto hat rail for attaching a screening clamp



Description	Part-No.	Type	PU
<b>Snap-on element</b>			
Length	18.00 mm	330088.0010	EMVRE H 1
			10

<b>Technical data</b>	<b>330088.0010</b>
weight approx.	0.70 kg/100 piece

General	
Material	Spring steel
Color	bare/stainless
Operation temperature range	-20 °C – 60 °C

**Comments**  
Suitable for all crosspieces and hat profile TS35

### Application example

### Dimensions

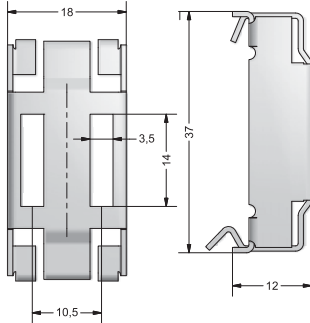

# EMC accessories

## Snap-on element can be snapped onto LSC profiles



Description	Part-No.	Type	PU
<b>Snap-on element</b>			
Length	24.00 mm	330074.0010	EMVRE 1
	43.50 mm	330068.0010	EMVRE 2
<b>Technical data</b>			
	<b>330074.0010</b>	<b>330068.0010</b>	
weight approx.	0.90 kg/100 piece	1.80 kg/100 piece	
<b>General</b>			
Material	Sheet steel 1.4310		
Color	bare/stainless		
Operation temperature range	0 °C – 60 °C		
<b>Comments</b>			
suitable for all webs of the series M, S, SN, MF, F, A			

### Dimensions

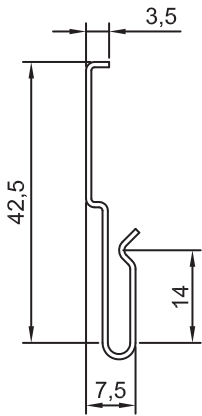
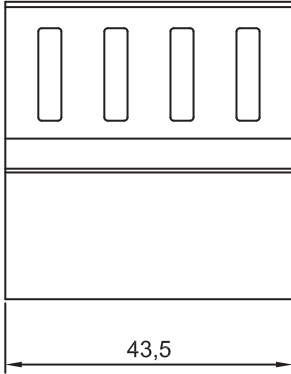

# EMC accessories - Ribbon cable earthing device

## Earthing strip, copper braiding, tin-plated Single wire Cu ETP UNI 5649-71, similar to DIN 72333



Dimensions

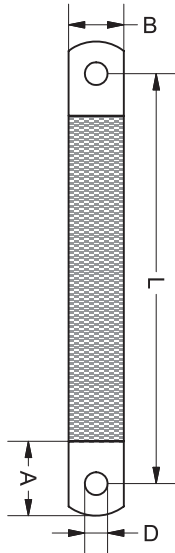

Description	Part-No.	Type	PU	
<b>both ends drilled, cold pressed</b>				
Cross section	10	346123.0010	EMVMB 10/100/6	10
	10	346112.0010	EMVMB 10/200/6	10
	16	346113.0010	EMVMB 16/200/8	10
	25	346116.0010	EMVMB 25/200/10	10

Technical data	346123.0010	346112.0010	346113.0010	346116.0010
Wire conductors	0.15 mm <sup>2</sup>			
D	6.5 mm		8.5 mm	10.5 mm
A	22.0 mm		25.0 mm	
B	12.0 mm		15.0 mm	23.0 mm
Weight (kg/m)	0.100		0.160	0.250
Approvals	UL E220029			
L	100.0 mm		200.0 mm	

General			
Amperage range	see standards table (e.g. EN 60204)		
Cable construction	individual conductor braided; cross-section rectangular		
Storage temperature range	-30 °C – 90 °C		
Operation temperature range	5 °C – 105 °C		

Accessories	Article number	Type	PU
Earthing set	331805.0001	ES 8	1
Earthing set	331816.0001	ES 6	1

Comments
D= hole diameter A= sleeve length B= width L= distance of hole

Other lengths are available on request

# EMC accessories - Ribbon cable earthing device

## Earthing strip, copper braiding, tin-plated Single wire Cu ETP UNI 5649-71, similar to DIN 72333



Dimensions

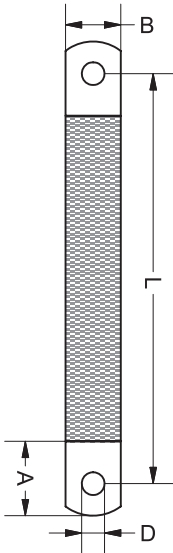

Description	Part-No.	Type	PU	
<b>both ends drilled, cold pressed</b>				
Cross section	10	346109.0010	EMVMB 10/300/M6	10
	16	346110.0010	EMVMB 16/300/8	10
	25	346111.0010	EMVMB 25/300/10	10
	16	346114.0010	EMVMB 16/500/8	10
<b>Technical data</b>				
	<b>346109.0010</b>	<b>346110.0010</b>	<b>346111.0010</b>	<b>346114.0010</b>
Wire conductors	0.15 mm <sup>2</sup>			
D	6.5 mm	8.5 mm	10.5 mm	8.5 mm
A	22.0 mm		25.0 mm	
B	12.0 mm	15.0 mm	23.0 mm	15.0 mm
Weight (kg/m)	0.100	0.160	0.250	0.160
Approvals	UL E220029			
L	300.0 mm		500.0 mm	
<b>General</b>				
Amperage range	see standards table (e.g. EN 60204)			
Cable construction	individual conductor braided; cross-section rectangular			
Storage temperature range	-30 °C – 90 °C			
Operation temperature range	5 °C – 105 °C			
<b>Accessories</b>				
	<b>Article number</b>	<b>Type</b>	<b>PU</b>	
Earthing set	331805.0001	ES 8	1	
Earthing set	331816.0001	ES 6	1	
<b>Comments</b>				
D= hole diameter A= sleeve length B= width L= distance of hole				
<b>Other lengths are available on request</b>				



# EMC accessories - Cable clip

## Cable clip



### Dimensions

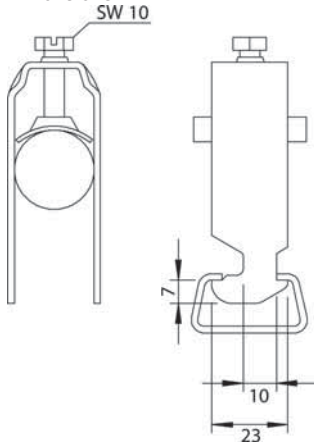

Description	Part-No.	Type	PU		
<b>Cable clip</b>					
	331000.0010	KS 0	10		
	331001.0010	KS 1	10		
	331002.0010	KS 2	10		
	331003.0010	KS 3	10		
	331004.0010	KS 4	10		
<b>Cable clip</b>					
<b>Technical data</b>	<b>331000.0010</b>	<b>331001.0010</b>	<b>331002.0010</b>	<b>331003.0010</b>	<b>331004.0010</b>
weight approx.	3.00 kg/100 pi- ece	3.20 kg/100 pi- ece	3.50 kg/100 pi- ece	6.80 kg/100 pi- ece	6.00 kg/100 pi- ece
Thread	M6			M8	
<b>General</b>					
Material	steel				
Color	galvanised				
Operation temperature range	0 °C – 60 °C				
Hexagon screw	slotted				
<b>Accessories</b>	<b>Article number</b>	<b>Type</b>	<b>PU</b>		
can be used on Lütze rails	345812	EMVS 03			
can be used on Lütze rails	345813	EMVS 04			
can be used on Lütze rails	333156	C rail			
<b>Comments</b>	Sold only with counter-shell, polypropylene plastic				



## 11. Technical information

<b>Bending cycles of high flexing cables</b>	<b>11.4</b>
<b>Motor, servo and inverter applications</b>	<b>11.5</b>
<b>Bus and network cables</b>	<b>11.6</b>
<b>ETHERNET - Overview</b>	<b>11.7</b>
<b>Approvals in North America</b>	<b>11.9</b>
<b>NFPA 79</b>	<b>11.10</b>
<b>Ampacity per National Electric Code (USA)</b>	<b>11.11</b>
<b>Current loads</b>	<b>11.12</b>
<b>Conductor resistances</b>	<b>11.14</b>
<b>Voltages per DIN VDE 0298 T1 / IEC 183</b>	<b>11.15</b>
<b>Conductor structure acc. DIN VDE 0295/IEC 60228 and AWG</b>	<b>11.16</b>
<b>Conductor labelling according to DIN 47100 in pairs</b>	<b>11.17</b>
<b>Colour code tables</b>	<b>11.18</b>
<b>Chemical resistance of PVC, TPE and PUR cable jackets</b>	<b>11.19</b>
<b>Properties of isolation materials</b>	<b>11.20</b>
<b>Bend radii for fixed installation</b>	<b>11.21</b>
<b>Torques for cable fittings</b>	<b>11.22</b>
<b>Design of the protection class designation according to EN 60529</b>	<b>11.23</b>
<b>Short abbreviation key according to VDE and DIN</b>	<b>11.24</b>
<b>Technical Terms</b>	<b>11.25</b>
<b>The price of copper</b>	<b>11.27</b>
<b>Conditions for the relinquishment of cable and wire spools</b>	<b>11.28</b>
<b>Certificates</b>	<b>11.29</b>

# LÜTZE SILFLEX®

## LÜTZE SILFLEX® - The flexible cable for harsh industrial environments

LÜTZE SILFLEX® is a cable for flexible applications without compulsory guide (not recommended for drag chains) and allows easy installation

LÜTZE SILFLEX® is available as control or power cable configurations. The offering includes besides the Standard PVC type options with UL and VDE approval and also halogen free versions with PUR jacket for harsh industrial environments

LÜTZE SILFLEX® can be used in machine and plant construction, conveyor systems, Industrial HVAC as well as many other industrial applications.

LÜTZE SILFLEX® cables are silicone free and are being used by many automotive plants in various different applications.



# LÜTZE SUPERFLEX® and LÜTZE SUPERFLEX® PLUS



## LÜTZE SUPERFLEX® sets Industry standards: longevity, reliability, flexibility

LÜTZE offers a variety of high flexing cables specifically designed for use in continuous motion applications such as drag chains. LÜTZE SUPERFLEX® and LÜTZE SUPERFLEX® Plus cables include high flexing control and motor supply cables, as well as electronic and network cables.

All LÜTZE SUPERFLEX® cables are compatible with all major brand drag chains.

LÜTZE SUPERFLEX® N is designed for moderate to higher performance flexing in short to medium length drag chains.

LÜTZE SUPERFLEX® N is offered with PVC or High Glide Insulation (TPE) insulation and with specially formulated PVC jacket.

LÜTZE SUPERFLEX® Plus PUR is designed for high performance flexing or longer drag chains. LÜTZE SUPERFLEX® Plus PUR contains high grade premium materials such as High Glide TPE insulation and PUR jackets for high performance applications in modern high speed machine tools.

All high flexing cables require special handling and installation techniques which are different from those of standard flexible control cables. To ensure the longest possible life span for your cable, it is important to follow installation procedures precisely.



Find here more informations  
about LÜTZE SUPERFLEX®  
<http://bit.ly/ZUdgUK>



# Bending cycles of high flexing cables

## LÜTZE SUPERFLEX® - longevity, reliability, flexibility

The high mechanical requirements in a drag chain require the use of special cables, which are designed for the usage in continuous motion application. The life span of cable in drag chains is strongly influenced by mechanical parameters of the application, as well as the carefulness of the installation.

Type of cable	Traveling distance in m	Bending radius = Factor x Cable-Ø (mm)	Velocity m/s	Acceleration m/s <sup>2</sup>	Cycles mio.
<b>LÜTZE SUPERFLEX® PLUS</b>					
Unshielded cable with special TPE or HGI insulation, PUR or TPE jacket	≤ 5	≥ 10 Ø	≤ 3	≤ 5	≥ 20
	≤ 20	≥ 7,5 Ø	≤ 5	≤ 10	≥ 10
	≤ 100	≥ 7,5 Ø	≤ 5	≤ 10	≥ 2

<b>LÜTZE SUPERFLEX® PLUS (C)</b>					
Shielded cable with special TPE or HGI insulation, PUR or TPE jacket	≤ 5	≥ 12 Ø	≤ 3	≤ 5	≥ 20
	≤ 20	≥ 10 Ø	≤ 5	≤ 10	≥ 10
	≤ 100	≥ 10 Ø	≤ 5	≤ 10	≥ 2

<b>LÜTZE SUPERFLEX®</b>					
Unshielded cable	≤ 5	≥ 12 Ø	≤ 3	≤ 5	≥ 10
	≤ 15	≥ 10 Ø	≤ 5	≤ 10	≥ 5

<b>LÜTZE SUPERFLEX® (C)</b>					
Shielded cable	≤ 5	≥ 15 Ø	≤ 3	≤ 5	≥ 10
	≤ 15	≥ 12 Ø	≤ 5	≤ 10	≥ 5

The values of this table show application-parameter and actual performed cycles in independent tests. The cycle count can only be compared, if every value is taken in consideration with each other. A valuation as "Million Operating Cycles" is insignificant, if traveling distance, velocity and bending radius is unknown.

## LÜTZE SUPERFLEX® PLUS M (C) PUR UL Servo 0,6 / 1 kV according to SIEMENS\* Standard Similar to SIEMENS MOTION-CONNECT 800PLUS

	Traveling distance in m	Bending radius = Factor x Cable-Ø (mm)	Velocity m/s	Acceleration m/s <sup>2</sup>	Cycles mio.
<b>LÜTZE SUPERFLEX® PLUS M (C) PUR UL Servo 0,6 / 1 kV</b>					
	≤ 3	≥ 10 Ø	≤ 5	≤ 50	≥ 10
	≤ 5	≥ 10 Ø	≤ 5	≤ 30	≥ 10
	≤ 10	≥ 10 Ø	≤ 5	≤ 15	≥ 10
	≤ 15	≥ 10 Ø	≤ 5	≤ 10	≥ 10
	≤ 50	≥ 10 Ø	≤ 5	≤ 5	≥ 10

# Motor, servo and inverter applications

LÜTZE offers a wide offering of cables especially designed for motor supply applications

## Standard

### LÜTZE SILFLEX® M (C) PVC 0,6/1 kV

For the standard motor supply application we recommend the use of our **LÜTZE SILFLEX® M PVC 0,6/1 kV** or the shielded **LÜTZE SILFLEX® M (C) PVC 0,6/1 kV** cables with PVC Insulation. These cables offer a high level of safety due to their higher voltage rating. This construction offers also high flexibility and an easy strip jacket and thus is ideal for field installation or routing to the machine.

## Servo and Frequency Converter

### LÜTZE SILFLEX® M (C) PVC UL SERVO 0,6/1 kV

### LÜTZE SUPERFLEX® PLUS M (C) PUR UL SERVO 0,6/1 kV

For any motor supply application with a Servo or Variable Frequency Drive we recommend our special design 0.6/1kV cables with TPM- or LÜTZE High Glide Insulation (HGI) based on Polypropylene.

These cables have a lower capacitance and improved voltage breakthrough resistance. For fixed or flexible use we offer

**LÜTZE SILFLEX® M (C) PVC UL SERVO 0,6/1 kV** which also meets the Siemens 6FX5008 Standard.

For use in continuous flexing applications, such as drag chains, there is a large variety of

**LÜTZE SUPERFLEX® PLUS M (C) PUR UL SERVO 0,6/1 kV** cables in many different configurations covering many different Servo applications.

**LÜTZE SUPERFLEX® PLUS** are found in many machine tools as well as automobile manufacturing because of their proven reliability.

## Variable Frequency Drives (Frequency converter)

### LÜTZE SILFLEX® B XLPE 3 (C) PVC 0,6/1 kV

When the cable run from the VFD to the motor is long, the right cable design matters! Cross linked Polyethylene is currently the best option as insulation material for this application, because this material offers very low capacitance and high impedance.

**LÜTZE SILFLEX® B XLPE 3 (C) PVC 0,6/1 kV** also has an optimized symmetrical construction to reduce stray currents.

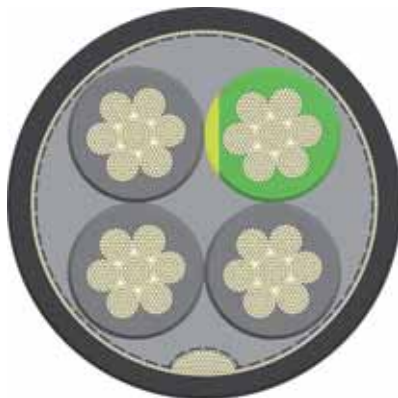

A-symmetrical design with one full size ground



Symmetrical design with 3 grounds

If electrical induction motors are controlled by a variable frequency drive, some voltage spikes can be induced in the motor shaft or motor housing. When this voltage overcomes the oil films resistance and enters the motor bearings it can lead to premature bearing failure. A symmetrical construction can improve the situation as it reduces the magnetic field and therefore the likelihood to induce voltage.

Another important point is the temperature rating of the cable. The better the temperature resistance of the material the more efficient can the cable transmit power. **LÜTZE SILFLEX® B XLPE 3 (C) PVC 0,6/1 kV** is setting a high standard with a temperature rating of 90 °C for the insulation and the jacket.

# Bus and network cables



## Bus- and Network cables

Bus-Systems have become a very vital part of factory automation and it's hard to imagine automation without it. Besides hardware and software components, passive components such as bus cables and connectors play an important role for reliable function of the system. Bus cables must comply with all electrical parameters of the particular system. There is no universally applicable bus cable as the individual requirements are to diverse.

LÜTZE offers robust, industrial grade Bus- and Network cables for the most common used systems worldwide. These cables are being offered for fixed and flexible application as well as continuous moving application in drag chains.

## Applications

### ASI - Actuator-Sensor-Interface

The AS-Interface per EN 50295 is a serial Actuator Sensor Network being used for digital signals in the lower field levels. It works in accordance to the Master Slave Principle and presents a cost effective alternative to other serial bus systems.

### Profibus

Profibus ist he most common Bus-System used in Europe in the area of automated manufacturing.

### Profibus PA

The engineering of these cables per IEC 61158-2 fulfills the requirements in process automation and also offers intrinsically safe connection to the field devices. Profibus PA is a synchronous protocol with DC-current flow free transmission, which is also often designated as H1. The IEC 61158-2 Technique is applied at the PROFIBUS-PA.

### Profibus DP

This Profibus variant, optimized through increased transmission speed and low installation cost, was especially designed for the communication between automation systems and decentralized peripheral devices in the field range. Profibus-DP substitutes the conventional parallel data communication with 24V or 0-20 mA. Lütze Profibus cables meet the specification for Profibus-DP type A according to EN 50254. Profibus-DP und Profibus FMS use the same transmission technology as well as a unified Bus protocol. Both variants can be operated simultaneously on one cable.

### Profibus Fast Connect®

These cables have an optimized radial, symmetrical construction and can facilitate the application of special tools. Thereby, bus connector plugs are able to be assembled in a fast and installation-friendly way.

### CAN-Bus

Can-Bus is specified according to ISO 11898. Primarily designed for automotive applications Can-Buses are used today for the exchange of digital information, Controller Area Network (CAN) for faster data transfer/data exchange.

### Interbus

The Interbus-S was published in 1987 as an open sensor/ actuator bus protocol. As a typical sensor/actuator fieldbus, it is configured for the cyclic processing of process data and hence differentiates significantly from data orientated field buses. The main application area of Interbus-S lays in production engineering,, process engineering, as well as transport and logistics. Here the main focus is both the automotive industry and the drive technology.

### DeviceNet

DeviceNet is a service related Network, based on the proven CAN-Technology for fast data exchange. The configuration consists of thick cable (aka Trunk cable) and thin cable (aka drop cable). The use of high flexing cables in drag chains is likewise possible. DeviceNet has been standardized by Open DeviceNet Vendor Association (ODVA) and is the leading bus system for industrial automation in North America.

### Industrial Ethernet

Ethernet ist the most commonly used communication technology. The Ethernet Standard allows for a remarkable increase in the bandwidth, from 12 Mbits/s for a bus system, to up to 10 Gbit/s. In the office world the Ethernet Standard has already established itself as the standard technology, however the requirements for wiring systems and active components in the industrial environment differ greatly from those in an office environment. On one hand the infrastructure must be more robust; and on the other hand criteria such as real time application require special IT solutions. Consequently, this has resulted in the development of various proprietary systems such as ProfiNet, EtherCAT, Modbus TCP and Powerlink with system specific components which may not be compatible with others. A structured Ethernet cabling according to EN 50173-3 should support each proprietary system.

While LÜTZE offers a large number of industrial Ethernet cable solutions we are pleased to have a special innovation with our drag chain suitable Cat6 Ethernet cable.



# ETHERNET – Overview

## 1. Correct Handling and Installation of Network Copper Cable

- Do not subject cable to tension
- Do not kink the cable
- Do not bend the cable more than 90° (See individual specifications for bending radius)
- Strip the cable as short as possible
- Do not crush cable when fastening
- Do not untwist the conductor pairs by **more than 0.5 inch**
- Terminate the shielding on both ends

## 2. LÜTZE ETHERNET Cables

We recommend shielded industrial Ethernet cable, such as LÜTZE ETHERNET cable, for use in industrial environment to ensure secure connectivity. Motors and other electrical noise producing devices are often located in close proximity to network cabling. EMI (Electro Magnetic Interference) and RFI (Radio Frequency Interference) can distort data transmission on copper-based network cable. To lessen or eliminate interference, called alien-crosstalk, the use of shielded industrial cable and connectors is recommended.

### Available LÜTZE ETHERNET Cables:

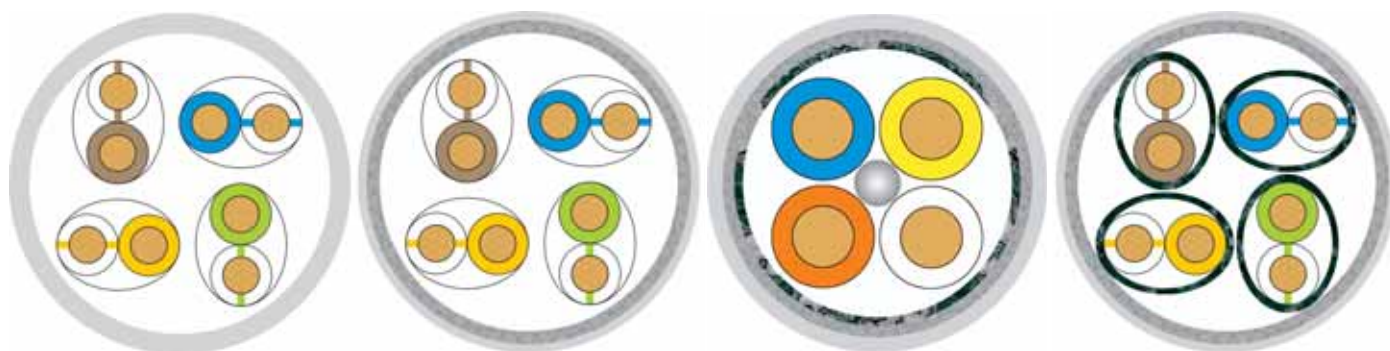

S/UTP	SF/UTP	SF/UTQ (Star Quad)	S/FTP
<b>Susceptibility for Interference</b>			
some	low	low	low
104337 CAT 5e	104335 CAT 5e 104366 CAT 5e 104347 CAT6	104301 CAT 5 104307 CAT 5 104302 CAT 5 104303 CAT 5	104338 CAT 6a 104331 CAT 7

## 3. Key for twisted pair cables according to ISO/IEC-11801 (2002)E

XX/YYZ

<b>XX</b> – outer jacket	<b>Y</b> – for the pair shielding	<b>ZZ</b> – wire pairing
<b>U</b> = unshielded	<b>U</b> = unshielded	<b>TP</b> = twisted pair (regular)
<b>F</b> = foiled shield	<b>F</b> = foiled shield	<b>TQ</b> = quad pair (star quad)
<b>S</b> = braided shield	<b>S</b> = braided shield	
<b>SF</b> = braided and foiled shield		

In order to utilize EMI/RFI shielding, the shield must be properly terminated at both ends!

# ETHERNET – Overview

## 4. ProfiNet – Star Quad Design and Termination

The star quad is a specific low-impedance cable configuration. Four conductors are twisted on a common axis. The conductors across from each other make a pair.

In Figure 1 the pairs are as follows:

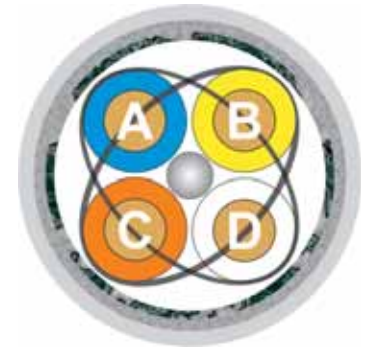
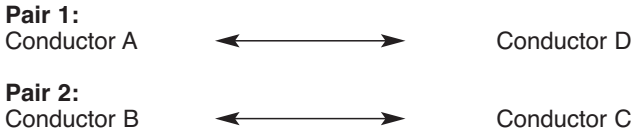

Figure 1

Other terminations than in Figure 1 lead to interferences, decreased connectivity or no connectivity at all.

## 5. Pin Assignment and Installation

RJ45 is the most common Ethernet connector and is available both shielded and unshielded. All pins of the RJ45 connector are used for 1000 Mbit/s (4-pair transmission). Four pins are used for 10/100 Mbit/s (2-pair transmission).

According to the EN 50173 standard, two color codes are defined for installation: T568A and T568B. It makes no difference which color code is used, however the same code should be used consistently throughout the entire installation. Mixing up the two color codes will result in malfunctions.

### Pin assignment RJ45 – Color code according to EN 50173 – hard wiring:

Pin#	Star Quad (ProfiNet)		Paired				Colorcode T568A		Colorcode T568B	
	100BASE-TX	Colorcode	10 BASE-T, 100BASE-TX	1000BASE-T						
1	Transmit+	yellow	Transmit+	BI_DA+	(bidirectional)	WH/GN	WH/OR			
2	Transmit-	orange	Transmit-	BI_DA-	(bidirectional)	GN	OR			
3	Receive+	white	Receive+	BI_DB+	(bidirectional)	WH/OR	WH/GN			
4	–		–	BI_DC+	(bidirectional)	BL	BL			
5	–		–	BI_DC-	(bidirectional)	WH/BL	WH/BL			
6	Receive-	blue	Receive-	BI_DB-	(bidirectional)	OR	GN			
7	–		–	BI_DD+	(bidirectional)	WH/BN	WH/BN			
8	–		–	BI_DD-	(bidirectional)	BN	BN			

## 6. ETHERNET Categories and Classes

	ProfiNet®	CAT 5	CAT 5e	CAT 6	CAT 6a	CAT 7
<b>Class</b>	D	D	De	E	Ea	F
<b>Construction</b>	2 pair (AWG 22)	2 pair (AWG 24, AWG 26)	4 pair (AWG 24, AWG 26)	4 pair (26 AWG)	4 pair (26 AWG)	4 pair (26 AWG)
<b>Speed</b>	10/100 Mbit/s	10/100 Mbit/s	10/100/1000 Mbit/s	10/100/1000 Mbit/s	10/100/1000/10000 Mbit/s	10/100/1000/10000 Mbit/s
<b>LAN Applications (max.)</b>	10BASE-T (2 pair) 100BASE-TX (2 pair)	10BASE-T (2 pair) 100BASE-TX (2 pair)	10BASE-T (2 pair) 100BASE-TX (2 pair) 1000BASE-T (4 pair)	10BASE-T 100BASE-TX 1000BASE-T	10BASE-T 100BASE-TX 1000BASE-T 10GBASE-T	10BASE-T 100BASE-TX 1000BASE-T 10GBASE-T
<b>Nominal Impedance</b>	100 Ohm	100 Ohm	100 Ohm	100 Ohm	100 Ohm	100 Ohm
<b>Bandwidth</b>	100 MHz	100 MHz	100 MHz	250 MHz	500 MHz	600 MHz
<b>max. lenght</b>	100 m (10BASE-T) 100 m (100BASE-TX)	100 m (10BASE-T) 100 m (100BASE-TX)	100 m (10BASE-T) 100 m (100BASE-TX) 100 m (1000BASE-T)	100 m (10BASE-T) 100 m (100BASE-TX) 100 m (1000BASE-T)	100 m (10BASE-T) 100 m (100BASE-TX) 100 m (1000BASE-T) 100 m (10GBASE-T)	100 m (10BASE-T) 100 m (100BASE-TX) 100 m (1000BASE-T) 100 m (10GBASE-T)
<b>CAT compatibility</b>	CAT 5	CAT 5	CAT 5	CAT 5, CAT 5e	CAT 5, CAT 6	CAT 5, CAT 6, CAT 6a
<b>ISO/IEC standard</b>	–	ISO/IEC 11801	ISO/IEC 11801	ISO/IEC 11801	Modification 1 ISO/IEC 11801	ISO/IEC 11801
<b>ANSI/TIA standard</b>	–	ANSI/TIA-568-B	ANSI/TIA-568-C.2	ANSI/TIA-568-C.2	ANSI/TIA-568-C.2	Not recognized



# Approvals for North America

## Different UL ratings for cables

Product certifications in North America will often be conducted by the National Recognized Testing Laboratories (NRTL). The NRTLs are determined by the Occupational Safety and Health Administration (OSHA). You can find a list of the current NRTLs on [www.osha.gov](http://www.osha.gov).

LÜTZE mainly uses Underwriters Laboratories (UL) to certify the products. UL (USA) and CSA (Canada) have an agreement that allows the usage of one certification for both USA and Canada.

In general there are two main certification classes:

Certification	Logos	Meaning
UL Recognized		„UL Recognized“ signifies that the product is rated as a component. A component is a part of an application. Cables with an „Appliance Wiring Material“ (AWM per Standard 758) are always „recognized“. Typically these cables are already installed on the machine when it ships.
UL Listed		„UL Listed“ signifies a cable as actually tested and proven for a specific use. This way the cable has to match the UL Standards and the requirements of the National Electric Code (NEC). Typically, cables with a UL Listing are used for field wiring in North America.

## Common „UL Listings“ for industrial cables:

UL Listing type	Description	Meaning
CM	Communication	Cables for data communication per UL category DUZX and NEC 800
CMG	Communication General	Cables for data communication per UL category DUZX and NEC 800
CMX	Communication Residential	Cables for data communication with restrictions per UL category DUZX and NEC 800
PLTC	Power Limited Tray Cable	Cables for tray applications per UL category QPTZ and NEC 725
PLTC-ER	Power Limited Tray Cable Exposed Run	Cables for tray applications per UL category QPTZ and NEC 725 (exposed use possible)
ITC	Instrumentation Tray Cable	Instrumentation cables for tray applications per UL category NYTT and NEC 727
ITC-ER	Instrumentation Tray Cable Exposed Run	Instrumentation cables for tray applications per UL category NYTT and NEC 727 (exposed use possible)
TC	Power and Control Tray Cable	Power and control cables for tray applications per UL category QPOR and NEC 336
TC-ER	Power and Control Tray Cable Exposed Run	Power and control cables for tray applications per UL category QPOR and NEC 336 (exposed use possible)
MTW	Machine Tool Wire	Single or multi conductor control cables for Machine Tool Wiring per UL category ZKHZ and NEC 670
Flexible VFD and Servo	Flexible VFD and Servo aka Flexible Motor Supply Cable	Power cables for motor and variable frequency drive applications per UL category ZJFH
WTTTC	Wind Turbine Tray Cable	Power and control cables for wind turbine applications per UL category ZGZN



This list only shows the common UL Listings for typical applications in the field of automation and does not stand for a complete overview of the current UL Listings.

It is possible to combine different UL Listings in one cable. LÜTZE offers a variety of cables with UL Listings for various industrial applications.

# NFPA 79

**NFPA 79** is the standard for industrial machines and installations in the USA. The NFPA 79 standard is published by National Fire Protection Agency (NFPA) and covers among other things the wiring of machine installations. The NFPA 79 standard works as an addition or an extension to the NEC (National Electric Code) which describes the general rules.

The current standard “NFPA 79 2015 Edition” allows the use of Appliance wiring material – “AWM” per UL Standard 758 again. The use of these cables on an industrial machine was explicitly prohibited in the 2007 Edition, which is no longer valid.

The 2007 regulations in regards AWM has been unsettling for many machine- and plant equipment manufacturers. The requirements of NFPA 79 standard are basically always met, if the cable has a listing of a National Recognized Testing Laboratory (NRTL) such as UL. It was possible that a cable carried both approvals and hence be marked with a  logo, as well as a .

The 2012 edition created a new option in article “12.9 special cables and conductors”, allowing the use of AWM cables as long as the suitability of cables for the industrial applications on the machine is given.

The reason for this restriction is that any AWM cable is considered a component and thus can only be allowed if the component is used within its intended use.

Previously allowed: 

Since 2012 Edition allowed:  

In order to use any AWM (UL 758) cable according to the current 2015, the requirements of paragraph 12.9 must be fulfilled. This paragraph lists three requirements of which at least one must be met.

To fulfill the most likely requirement, you have to use AWM cable which is suitable for the industrial use. This restriction shall prevent that machine- and equipment manufacturers use a cable which is not suitable for the intended use. The suitability can be checked easily by matching the UL AWM Style to the application. The UL AWM Styles provide, among other things, information about the materials and wall thickness of a cable. Any jacket-Style for example, includes information about:

- Material
- Wall thickness
- Voltage (Volt)
- Temperature range
- Use statement

Example: AWM 2587 describes a 600 V 90 °C cable with PVC jacket for external wiring.

The actual use, for example, may not exceed the rated voltage of this cable. Typical rated voltages for AWM cables are 30, 300, 600 and 1000 V.

For this purpose LÜTZE has expanded the offering of suitable industrial AWM cables per UL 758 Standard. All AWM Styles and the conforming rated voltages are marked explicitly in the catalog, so that you can find matching cables for every industrial application.

More information about the UL Standard 758 and the Style details you can find on [www.ul.com](http://www.ul.com). Information about NFPA 79 you can find on [www.nfpa.org](http://www.nfpa.org).

# Ampacity per National Electric Code (USA)

## Calculation of the max. ampacity, based on "NEC 2014 Edition"

According to NEC Tabelle 310.15(B), Edition 2014

Allowable Ampacities of Insulated Conductors Rated 0 Through 2000 Volts, 60 °C – 90 °C (140 °F – 194 °F). Not More Than Three Current-Carrying Conductors in Raceway, Cable, or Earth (Directly Buried), Based on Ambient Temperature of 30 °C (86 °F)

Size AWG oder kcmil	Temperature Rating of Conductor		
	60 °C / 140 °F	75 °C / 167 °F	90 °C / 194 °F
	Types TW, UF	Types RHW, THHW, THW, THWN, XHHW, USE, ZW	Types TBS, SA, SIS, FEP, FEPB, MI, RHH, RHW-2, THHN, THHW, THW-2, THWN-2, USE-2, XHH, XHHW, XHHW-2, ZW-2
	COPPER		
18	–	–	14
16	–	–	18
14**	15	20	25
12**	20	25	30
10**	30	35	40
8	40	50	55
6	55	65	75
4	70	85	95
3	85	100	115
2	95	115	130
1	110	130	145
1/0	125	150	170
2/0	145	175	195
3/0	165	200	225
4/0	195	230	260

\* Refer to NEC 310.15(B)(2) for the ampacity correction factors where the ambient temperature is other than 30 °C / 86 °F

\* Refer to NEC 240.4(D) for conductor overcurrent protection limitations.

## Correction Factors

Ambient temperature (Based on 310.15(B)(2)(a))

For ambient temperatures other than 30 °C / 86 °F, multiply the allowable ampacities shown above by the appropriate factor shown below.

Ambient temperature	60 °C / 140 °F	75 °C / 167 °F	90 °C / 194 °F
21-25 °C / 70-77 °F	1.08	1.05	1.04
26-30 °C / 78-86 °F	1	1	1
31-35 °C / 87-95 °F	0.91	0.94	0.96
36-40 °C / 96-104 °F	0.82	0.88	0.91
41-45 °C / 105-113 °F	0.71	0.82	0.87
46-50 °C / 114-122 °F	0.58	0.75	0.82
51-55 °C / 123-131 °F	0.41	0.67	0.76
56-60 °C / 132-140 °F	–	0.58	0.71
61-70 °C / 141-158 °F	–	0.33	0.58
71-80 °C / 159-176 °F	–	–	0.41

## Number of current carrying conductors

Per NEC Table 310.15(B)(3)A

Adjustment Factors for more than three current carrying conductors in Raceway or cable.

Number of Current-Carrying Conductors	Percent of values in tables 310.15(B) through 310.15(B)(19) as adjusted for ambient temperature if necessary
1-3	100
4-6	80
7-9	70
10-20	50
21-30	45
31-40	40
41 and more	35

Number of conductors is the total number of conductors in the raceway or cable adjusted in accordance with 310.15(B)(5) and (6)

## Example:

Calculation of 80 °C PUR AWG12 motor supply cable with control pair at ambient temperature of 50 °C and a required ampacity of 12,5 Ampere

- |                                       |      |   |                                                          |
|---------------------------------------|------|---|----------------------------------------------------------|
| 1. Factor ambient temperature         | 0,75 | → | 25 A x 0,75 x 0,8 = 15 A > 12,5 A                        |
| 2. Factor current carrying conductors | 80   |   | Our recommendation AWG12 (equals ca. 4 mm <sup>2</sup> ) |

**Note:** The given values are reference numbers to calculate the required cable sizes. Friedrich Lütze GmbH is not responsible for the conformity of the values provided by the NEC.

# Current loads

Current rating of cables with rated voltage up to 1000 V and of heat-resistant cables.  
(cf. VDE 0298-4, 2003-08, Table 11)

Installation type	Group 1	Group 2	Group 3	
	Single-conductor cable	Multi-conductor cable for household - and hand-held equipment	Multi-conductor cable except household - a. hand-held equipm.	
	<ul style="list-style-type: none"> <li>• Rubber-insulated</li> <li>• PVC-insulated</li> <li>• TPE-insulated</li> <li>• Heat-resistant</li> </ul>	<ul style="list-style-type: none"> <li>• Rubber-insulated</li> <li>• PVC-insulated</li> <li>• TPE-insulated</li> </ul>	<ul style="list-style-type: none"> <li>• Rubber-insulated</li> <li>• PVC-insulated</li> <li>• TPE-insulated</li> </ul>	
Number of current carrying conductors	Free in air	On or at the surface		
Nominal cross section in mm <sup>2</sup>	1	2	3	2 oder 3
		Current rating in Ampere		
0,14 *	3	-	-	2
0,25 *	5	-	-	4
0,34 *	8	-	-	6
0,5 *	12	3	3	9
0,75	15	6	6	12
1,0	19	10	10	15
1,5	24	16	16	18
2,5	32	25	20	26
4	42	32	25	34
6	54	40	-	44
10	73	63	-	61
16	98	-	-	82
25	129	-	-	108
35	158	-	-	135
50	198	-	-	168
70	245	-	-	207
95	292	-	-	250
120	344	-	-	292
150	391	-	-	335
185	448	-	-	382
240	528	-	-	453
Based on DIN VDE 0298-4 2003-08	Table 11 column 1 e.g. H07V-K, LÜTZE SUPERFLEX® PLUS PUR single-conductor	Table 11 column 3 and 4		Table 11 column 5 z.B. LÜTZE SILFLEX® and LÜTZE SUPERFLEX® cables

Conversion factor for			
Deviating ambient temperature	Temperature	-	Temperature
Multi-conductor cables	-	-	Number of conductors

\* not official part of VDE 0298-4 2003-08. Current rating in accordance with 0891-1 or 0298-4 2003-08.

## Note 1:

This table deviates from the table in VDE 0298-4. If there is uncertainty, the latest version of DIN VDE 0298-4 is valid. The actual current rating is also influenced by deviating ambient temperature, as well as the number of conductor in a cable. In this case the derating factors from table "Temperature" and "Number of conductors" must be used.

## Note 2:

The here shown descriptions are reference values and in simplified form taken from VDE 0298-4 2003-8. If necessary additional conversion factors for accumulation, installation in tubes or cable racks must be taken from the entire version of VDE 0298-4 2003-8. Should there be newer versions available after printing deadline, these must be considered. LÜTZE assumes no guarantee for the completeness or the correctness of any information provided here.

# Current loads

## Temperature

Conversion factors for deviating ambient temperature  
(see VDE 0298-4 2003-08 Table 17, column 4, 5 and 7)

Ambient temperature	Factor		
	70 °C at the conductor	80 °C at the conductor	90 °C at the conductor
10 °C	1,22	1,18	1,15
15 °C	1,17	1,14	1,12
20 °C	1,12	1,10	1,08
25 °C	1,06	1,05	1,04
30 °C	1,00	1,00	1,00
35 °C	0,94	0,95	0,96
40 °C	0,87	0,89	0,91
45 °C	0,79	0,84	0,87
50 °C	0,71	0,77	0,82
55 °C	0,61	0,71	0,76
60 °C	0,50	0,63	0,71
65 °C	0,35	0,55	0,65
70 °C	-	0,45	0,58
75 °C	-	0,32	0,50
80 °C	-	-	0,41
85 °C	-	-	0,29

## Number of conductors

Conversion factors for multi-conductor cable with a nominal cross section up to 10 mm<sup>2</sup> (see VDE 0298-4 2003-08 Table 26, column 2)

Number of loaded conductors	Factor
5	0,75
7	0,65
10	0,55
14	0,50
19	0,45
24	0,40
40	0,35
61	0,30

### Note:

If necessary additional conversion factors for accumulation, installation in tubes or cable racks must be taken from the entire version of VDE 0298-4 2003-8. LÜTZE assume no guarantee for the completeness or the correctness of any information provided here.

# Conductors resistances

The values according to DIN VDE 0295 are listed depending on the conductor cross-section and conductor class. The diameter of the individual wires of every conductor, beginning with 0,5 mm<sup>2</sup>, are the specified maximal values allowed (see VDE 0295), that are required for compliance with the maximum wire resistance 20 °C (68 °F), not exceeded.

Nominal cross section mm <sup>2</sup>	Cu conductor not insulated (Ω/km)		Cu conductor tinned (Ω/km)		Welding cable (Ω/km)	
	class	class	class	class	Cu conductor	Cu conductor
	1 and 2	5 and 6	1 and 2	5 and 6	not insulated	tinned
0,05		380		392		
0,08		237		244		
0,11		170		175		
0,126		150		155		
0,14		134		138		
0,22		85		99		
0,25		76		79		
0,34		53		56		
0,5	36,0	39,0	36,7	40,1		
0,75	24,5	26,0	24,8	26,7		
1,0	18,1	19,5	18,2	20,0		
1,5	12,1	13,3	12,2	13,7		
2,5	7,41	7,98	7,56	8,21		
4,0	4,61	4,95	4,70	5,09		
6,0	3,08	3,30	3,11	3,39		
10,0	1,83	1,91	1,84	1,95		
16,0	1,15	1,21	1,16	1,24	1,16	1,19
25,0	0,727*	0,780	0,734	0,795	0,758	0,780
35,0	0,524*	0,554	0,529	0,565	0,536	0,552
50,0	0,387*	0,386	0,391	0,393	0,379	0,390
70,0	0,268*	0,272	0,270	0,277	0,268	0,276
95,0	0,193*	0,206	0,195	0,210	0,198	0,204
120,0	0,153*	0,161	0,154	0,164	0,155	0,159
150,0	0,124*	0,129	0,126	0,132	0,125	0,129
185,0	0,0991	0,106	0,100	0,108	0,102	0,105
240,0	0,0754	0,0801	0,0762	0,0817		
300,0	0,0601	0,0641	0,0607	0,0654		
400,0	0,0470	0,0486	0,0475	0,0495		

Class 1 = single-wire strand for single and multi-wire cables

Class 2 = multi-wire strand for single and multi-wire cables

Class 5 = multi-strand Cu conductor for single and multi-wire cables

Class 6 = superfine strand Cu conductor for single and multi-wire cables

\*For mineral isolated cables (only for class 1)



# Voltages per DIN VDE 0298 T1 / IEC 183

## Rated voltage, operating voltage and maximum voltage

### Voltages are specified as U<sub>0</sub>/U

The rated voltage following IEC 183 and DIN VDE 0298 T1 are specified as U<sub>0</sub>/U whereas the rated voltage between one conductor and the metallic outer cover or the ground is (ambient medium) and U the rated voltage between two phases in a three-phase supply is, whereas  $U = \sqrt{3} U_0$  ( $\approx$  Factor 1,73).

### The maximal permitted voltage U<sub>m</sub> is also determined.

The operating voltage is the voltage between conductors or conductor and ground of a high-voltage system during undisturbed operation. The operating voltage of a system must not permanent exceed the rated voltage by 10%.

Additionally the maximal permanent permitted voltage U<sub>m</sub> following IEC 183 is given in brackets. (U<sub>0</sub>/U (U<sub>m</sub>))

As the insulation of the cables is measured for the voltage U<sub>0</sub>, the cables are also suitable for the usage in single-phase systems, for which:

- Both outer conductor are insulated, with the rated voltage  $U_n = 2U_0$
- One outer conductor is grounded, with the rated voltage  $U_n = U_0$

Rated voltage	Maximal permitted voltage	Systems with:					
		3-phases		Single-phases AC			
		Rated voltage	Maximal permitted voltage	Between 2 phases		Phase / Ground	
U <sub>0</sub> /U [V]	U <sub>m</sub> [V]	U <sub>n</sub> = U <sub>0</sub> x 1,73 [V]	U <sub>bmax</sub> [V]	Rated voltage	Maximal permitted voltage	Rated voltage	Maximal permitted voltage
				U <sub>n</sub> = 2 x U <sub>0</sub> [V]	U <sub>bmax</sub> = [V] $\frac{2U_m}{1,73}$	U <sub>n</sub> < U <sub>0</sub> [V]	U <sub>bmax</sub> = [V] $\frac{U_m}{1,73}$
300 / 500	550	500	550	600	700	300	350
450 / 750	825	750	825	900	1050	450	520
600 / 1000	1100	1000	1000	1200	1400	600	700

# Conductor structure according to DIN VDE 0295 / IEC 60228 and AWG

## Conductor structure according to DIN VDE 0295 / IEC 60228

Cross section mm <sup>2</sup>	Multi-stranded conductor class 2	Many-stranded conductor	Finely stranded conductor class 5	Superfine strand conductor class 6		
	VDE 0295		VDE 0295	VDE 0295		
Number of strands and individual strand mm						
0,14				18 x 0,10	18 x 0,10	36 x 0,07
0,25			14 x 0,15	32 x 0,10	32 x 0,10	65 x 0,07
0,34		7 x 0,25	19 x 0,15	42 x 0,10	42 x 0,10	88 x 0,07
0,38		7 x 0,27	12 x 0,20	21 x 0,15	48 x 0,10	100 x 0,07
0,50	7 x 0,30	7 x 0,30	16 x 0,20	28 x 0,15	64 x 0,10	131 x 0,07
0,75	7 x 0,37	7 x 0,37	24 x 0,20	42 x 0,15	96 x 0,10	195 x 0,07
1,00	7 x 0,43	7 x 0,43	32 x 0,20	56 x 0,15	128 x 0,10	260 x 0,07
1,50	7 x 0,52	7 x 0,52	30 x 0,25	84 x 0,15	192 x 0,10	392 x 0,07
2,50	7 x 0,67	19 x 0,41	50 x 0,25	140 x 0,15	320 x 0,10	651 x 0,07
4	7 x 0,85	19 x 0,52	56 x 0,30	224 x 0,15	512 x 0,10	1040 x 0,07
6	7 x 1,05	19 x 0,64	84 x 0,30	192 x 0,20	768 x 0,10	1560 x 0,07
10	7 x 1,35	49 x 0,51	80 x 0,40	320 x 0,20	1280 x 0,10	2600 x 0,07
16	7 x 1,70	49 x 0,65	128 x 0,40	512 x 0,20	2048 x 0,10	
25	7 x 2,13	84 x 0,62	200 x 0,40	800 x 0,20	3200 x 0,10	
35	7 x 2,52	133 x 0,58	280 x 0,40	1120 x 0,20		
50	19 x 1,83	133 x 0,69	400 x 0,40	705 x 0,30		
70	19 x 2,17	189 x 0,69	356 x 0,50	990 x 0,30		
95	19 x 2,52	259 x 0,69	485 x 0,50	1340 x 0,30		
120	37 x 2,03	336 x 0,67	614 x 0,50	1690 x 0,30		
150	37 x 2,27	392 x 0,69	765 x 0,50	2123 x 0,30		
185	37 x 2,52	494 x 0,69	944 x 0,50	1470 x 0,40		
240	61 x 2,24	627 x 0,70	1225 x 0,50	1905 x 0,40		
300	61 x 2,50	790 x 0,70	1530 x 0,50	2385 x 0,40		
400	61 x 2,89		2035 x 0,50			
500	61 x 3,23		1768 x 0,60			

The number of the strands is non-binding. The VDE 0295 determines only the maximum diameter of the single wire that is required for compliance with the maximum wire resistance at 20 °C.

## Conductor structure according to AWG

Cross section mm <sup>2</sup>	AWG	Copper wire mm Ø	Braid copper not insulated — Wire structure					Standard values			
			flexible	very flexible		highly flexible		A max.	Cu weight		
			mm Ø	mm Ø	mm Ø	mm Ø	mm Ø	Ω/km	at 20 °C	kg/km	
0,08		0,32	10 x 0,10	0,37			40 x 0,05	0,37	210	0,5	0,71
(0,09)	28	0,32	7 x 0,13	0,38			19 x 0,08	0,40	195		0,75
0,10		0,36	14 x 0,10	0,44	28 x 0,07	0,44	51 x 0,05	0,42	190	1,0	0,98
0,14	26	0,39	18 x 0,10	0,49	36 x 0,07	0,49	72 x 0,05	0,50	138	1,5	1,27
(0,13)		0,40	7 x 0,16	0,49	10 x 0,13	0,53	19 x 0,10	0,51	130		1,30
(0,21)	24	0,51	7 x 0,20	0,61	19 x 0,13	0,61	41 x 0,08	0,58	85		2,00
0,25		0,57	14 x 0,15	0,66	32 x 0,10	0,66	128 x 0,05	0,75	77	2,5	2,27
(0,32)	22	0,64	7 x 0,25	0,76	19 x 0,16	0,80	26 x 0,13	0,76	56		3,00
0,34		0,64	7 x 0,25	0,75	42 x 0,10	0,74	180 x 0,05	0,80	56	4,5	3,10
0,50		0,80	16 x 0,20	0,95	28 x 0,15	0,95	256 x 0,05	1,00	39	6,0	4,50
(0,52)	20	0,81	7 x 0,32	0,90	19 x 0,20	0,94	41 x 0,13	0,91	33		5,00
0,75		0,98	24 x 0,20	1,20	42 x 0,15	1,20	385 x 0,05	1,20	26	10,0	6,90
(0,82)	18	1,02	7 x 0,40	1,22	19 x 0,25	1,27	65 x 0,13	1,20	21		8,00
1,00		1,15	32 x 0,20	1,30	57 x 0,15	1,30	511 x 0,05	1,40	20	15,0	9,20
(1,31)	16	1,30	7 x 0,51	1,52	19 x 0,30	1,47	105 x 0,13	1,50	16		11,00
1,50		1,40	30 x 0,25	1,60	85 x 0,15	1,85	196 x 0,10	1,85	14	20,0	14,10
(2,08)	14	1,62	7 x 0,64	1,85	19 x 0,36	1,85	105 x 0,16	1,85	11		19,00
2,50		1,80	51 x 0,25	2,10	142 x 0,15	2,25	322 x 0,10	2,40	8	25,0	23,20
(3,31)	12	2,05	7 x 0,80	2,50	19 x 0,46	2,35	165 x 0,16	2,41	6		28,00
(5,26)	10	2,60	37 x 0,40	2,80					3,8		42,00

# Conductor labelling according to DIN 47100 in pairs

## Pair identification colour repetition after 45 pairs

Electronic data cables and computer cables with paired stranding. The first colour is the base colour of the strand. For multiple colour strands of the pair, the identification consists of a base colour and a ring colour. The second colour is applied as ring marking, ring width approx. 2 – 3 mm. A certain amount of blur of the identification colour at the edges and a small offset of both half rings are permitted from a manufacturing technique perspective.

The manner of counting occurs from outside to inside through all layers pairwise consecutively.

## Paired stranding

Pair no.	a-strand	b-strand
1 23 45	white	brown
2 24 46	green	yellow
3 25 47	grey	pink
4 26 48	blue	red
5 27 49	black	violet
6 28 50	grey/pink	red/blue
7 29 51	white/green	brown/green
8 30 52	white/yellow	yellow/brown
9 31 53	white/gray	grey/brown
10 32 54	white/pink	pink/brown
11 33 55	white/blue	brown/blue

Pair no.	a-strand	b-strand
12 34 56	white/red	brown/red
13 35 57	white/black	brown/black
14 36 58	grey/green	yellow/grey
15 37 59	pink/green	yellow/pink
16 38 60	green/blue	yellow/blue
17 39 61	green/red	yellow/red
18 40	green/black	yellow/black
19 41	grey/blue	pink/blue
20 42	grey/red	pink/red
21 43	grey/black	pink/black
22 44	blue/black	red/black

## Colour table according to RAL

## Colour abbreviation according to HD 457

Colour	Short abbreviation	RAL	DESINA Outer jacket colour	DIN 47002 German	IEC 757 English
black	sw	9005	Power cable	sw	BK
brown	bn	8003		br	BN
red	rt	3000		rt	RD
orange	org	2003	Power cable	or	OG
yellow	ge	1021	Sensor/-actor cables	ge	YE
green	gn	6018	Signal cable	gn	GN
blue	bl	5015		bl	BU
violet	vio	4001	Bus/Fiber optic cable	vi	VT
silvergrey	gr	7001		gr	GY
pebble grey		7032			
window grey		7040	Control cable		
white	ws	9010		ws	WH
pink	rs	3015		pk	PK
turquoise (petrol)	tk	5018		tq	TQ
green/yellow	gnge	6018/1021		gnye	GNYE
silver		-			SR
dark blue	dbl	5010		dbl	
dark brown	dbn	8014		dbn	
transparent	tr	-		tr	

# Colour code tables

## Strand colour according to DIN VDE 0293-308

Cable and cables without green-yellow strand

Number of strands	Colours of the strands				
2	blue	brown	-	-	-
3	-	brown	black	grey	-
4	blue	brown	black	grey	-
5	blue	brown	black	grey	black

Cable and cables without green-yellow strand

Number of strands	Colours of the strands				
	Ground conductor	Active conductor			
3	green-yellow	blue	brown	-	-
4	green-yellow	-	brown	black	grey
5	green-yellow	blue	brown	black	grey

Not insulated concentric conductors, such as metallized jackets, armoring or shields are not considered as conductors in this table. a concentric conductor is identified by its arrangement and thus does not need to be identified by its colour.

## Strand colours according to DIN 47100

Electronic data cables and computer cables with stranding with colour repetition after 45 strands. The first colour is the base colour of the strand.

For multiple colour strands, the identification marking consists of a base colour and a ring colour. The second or third colour respectively is applied as ring identification marking. Ring width approx. 2 – 3 mm. A certain amount of blur of the identification colour at the edges and a small offset of both half rings is permitted. The manner of counting occurs from outside to inside through all layers consecutively.

No. Base/ring colours	No. Base/ring colours
1 white	32 yellow/blue
2 brown	33 green/red
3 green	34 yellow/red
4 yellow	35 green/black
5 grey	36 yellow/black
6 pink	37 grey/blue
7 blue	38 pink/blue
8 red	39 grey/red
9 black	40 pink/red
10 violet	41 grey/black
11 grey/pink	42 pink/black
12 red/blue	43 blue/black
13 white/green	44 red/black
14 brown/green	45 white
15 white/yellow	46 brown
16 yellow/brown	47 green
17 white/grey	48 yellow
18 grey/brown	49 grey
19 white/pink	50 pink
20 pink/brown	51 blue
21 white/blue	52 red
22 brown/blue	53 black
23 white/red	54 violet
24 brown/red	55 grey/pink
25 white/black	56 red/blue
26 brown/black	57 white/green
27 grey/green	58 brown/green
28 yellow/grey	59 white/yellow
29 pink/green	60 yellow/brown
30 yellow/pink	61 white/grey
31 green/blue	

## Strand colour according to IEC for electronic cables with AWG design

Strand no.	Colour
1	black
2	brown
3	red
4	orange
5	yellow
6	green
7	blue
8	violet
9	grey
10	white
11	white-black
12	white-brown

The double color green-yellow may only be used for the grounding conductor (yellow is the base color). For the remaining double colors, the base color is white respectively.

For possibly required additional double colors, grey or brown are recommended as additional base colors.

# Chemical resistance of PVC, TPE and PUR cables jackets

Anorganic	Concentration	PVC	TPE	PUR
Alaune	c.s.	+	+	
Aluminium salts	ec.	+	+	+
Ammonia, a	10 %	+	+	+
Ammonium acetate, a	ec.	+	+	
Ammonium carbonate, a	ec.	+	+	-
Ammonium chloride, a	ec.	+	+	+
Barium salts	ec.	+	+	+
Boric acid	100 %	+	+	O
Calcium chlorid, a	c.s.	+	+	O
Calcium chlorid, a	10 % and 40 %			+
Calcium nitrate, a	c.s.	+	+	
Chrom salts, a	c.s.	+	+	+
Calium carbonate, a (potash)		+	+	
Potassium chlorate, a	c.s.	+	+	
Potassium chloride, a	c.s.	+	+	O
Calcium dichromate, a		+	+	
Calcium iodide, a		+	+	
Calcium nitrate, a	c.s.	+	+	+
Potassium permanganate, a		O	O	-
Potassium sulfate, a		+	+	+
Copper salts, a	c.s.	+	+	+
Magnesium salts, a	c.s.	+	+	O
Sodium carbonate, a (Natron)		+	+	O
Sodium bisulfate, a		+	+	
Sodium chloride, a (common salt)		+	+	+
Sodium thiosulfate, a (fixing salt)		+	+	O
Nickel salts, a	c.s.	+	+	+
Phosphoric acid	50 %	+	+	-
Mercury	100 %	+	+	+
Mercury salts, a	c.s.	+	+	+
Nitric acid	30 %	-	-	-
Hydrochloric acid	concentration	-	-	-
Sulfur	100 %	+	+	+
Sulfur dioxide,	gaseous	+	+	O
Carbon disulfide		-	-	-
Hydrogen sulfide		+	+	-
Sea water		+	+	+
Silver salts, a		+	+	+
Hydrogen peroxide, a	3 %	+	+	+
Zinc salts, a		+	+	-
Tin(II) chloride		+	+	-
Organic	Concentration	PVC	TPE	PUR
Ethyl alcohol	100 %	-	-	-
Formic acid	30 %	-	-	-
Benzine/Benzene		-	O	+
Succinic acid, a	c.s.	+	+	-
Acetic acid	20 %	O	O	O
Hydraulic oil		-	*	O*
Isopropyl alcohol	100 %	-	-	O
Kerosene			O	O
Machine oil		O*	O*	+
Methyl alcohol, a	100 %	O	O	O
Mineral oil, depending on type (ASTM)			*	*
Oxalic acid, a	c.s.	+	+	
Paraffin oil			+	+
Plant oils and greases		O/+*	+	O/+*
Cutting oil		O*	O/+*	+
Tartaric acids, a		+	+	
Citric acid		+	+	

**Legend:** ec. = each concentration      a = aqueous  
c.s. = cold saturated                      + = resistant  
O = conditionally resistant              - = unstable  
\* = depending on the additives in oil

Disclaimer: This information shall only serve as support for choosing a suitable material for use with chemical substances. Prior to the final installation a test of the material should be performed with the chemical substances under prospective conditions of use. Lütze assumes no guarantee for the completeness or the correctness of this content, and declines all liability claims, which relate to loss or damage, which was caused by the use of the presented information or recommendations.

All specification refer to room temperature!

# Properties of isolation materials

Material	Abb.	Short abbreviation	Service temperature °C	Dielectric constant 10 <sup>3</sup>	spec. contact Ohm x cm	Tensile strength N/mm <sup>2</sup>	Elongation at break %	Absorption of water (20 °C) %	Weathering resistance	Fuel resistance	Oil resistance	Flammability
Polyvinyl chloride	PVC	Y	-30/+70	4 - 7	10 <sup>12</sup> - 10 <sup>15</sup>	10 - 25	150 - 300	0.4	moderate	moderate	good	self-extinguishing
Polyvinyl chloride heat resistant	PVC	Y	-20/+90	3.5	10 <sup>12</sup> - 10 <sup>15</sup>	10 - 25	150 - 300	0.4	moderate	moderate	good	self-extinguishing
High pressure polyethylene	LDPE	2Y	-50/+70	2.3	10 <sup>17</sup>	20 - 30	500	0.1	good	low	moderate	flammable
Low pressure polyethylene	HDPE	2Y	-50/+100	2.3	10 <sup>17</sup>	30	800	0.1	moderate	low	moderate	flammable
Polyurethane	PUR	11Y	-40/ +90/100	4.0 - 6.0	10 <sup>12</sup>	30 - 45	300 - 600	1.5	very good	good	good	self-extinguishing
Polyamide	PA	4Y	-40/+80	3.5 - 7.0	10 <sup>14</sup>	50 - 180	200 - 300	1 - 2	good	moderate	good	flammable
Polybutylene terephthalate	PBTP	-	-60/+110	3.0 - 4.0	10 <sup>16</sup>	50 - 100	50 - 300	0.5	good	good	good	flammable
Polytetrafluoroethylene	PTFE	5Y	-190/+260	2.1	10 <sup>18</sup>	14 - 40	240 - 400	0.01	very good	very good	very good	not flammable
tetrafluoroethylene hexafluoro-propylene Copolymer	FEP	6Y	-100/+200	2.1	10 <sup>18</sup>	20 - 25	250 - 350	0.01	very good	very good	very good	not flammable
Ethylene tetrafluoroethylene	ETFE	7Y	-100/+150	2.6	10 <sup>16</sup>	40 - 50	100 - 300	0.01	very good	very good	very good	not flammable
Perfluoroalkoxy polymer	PFA	-	-190/+260	2.1	10 <sup>15</sup>	30	300	0.01	very good	very good	good	not flammable
Chloroprene rubber	CR	5G	-40/+100	6.0 - 8.0	10 <sup>13</sup>	25	450	1.0	very good	low	good	self-extinguishing
Silicon rubber	SI	2G	-60/+180	2.8 - 3.2	10 <sup>15</sup>	5 - 10	200 - 350	1.0	very good	low	moderate	flame
Ethylene vinyl acetate	EVA	4G	-30/+125	5 - 7	10 <sup>13</sup>	5	200	0.01	good	low	low	flammable
Ethylene propylene rubber	EPM/ EPDM	3G	-30/+120	3.2	10 <sup>14</sup>	5 - 25	200 - 450	0.02	good	low	low	flammable
Thermoplastic polyolefin Elastomer	TPE-O	18Y	-40/+120	2.7 - 3.6	5 x 10 <sup>14</sup>	>6	>400	1.5	very good	moderate	moderate	flammable
Thermoplastic polyester Elastomer	TPE-E	12Y	-70/+125	3.7 - 5.1	10 <sup>12</sup>	3 - 25	280 - 650	0.3 - 0.6	very good	good	very good	flammable
Styrol triblock Copolymer	TPE-S	-	-75/ +105/140	2.2 - 2.6	10 <sup>16</sup>	9 - 25	500 - 700	1 - 2	moderate	good	low	flammable

Only for basic materials, deviations are possible depending on the indented use/design.

# Bend radii for fixed installation

## Bend radiuses according to DIN and VDE specifications

The bending radiuses must not fall short of the specified bending radiuses in the tables. A shortened service life is to be anticipated for falling below these. Smallest permitted bending radiuses for high voltage current systems according to DIN VDE 0298 – section 3 to nominal voltage 0.6/1 kV.

## Cables for fixed installation according to DIN VDE 0298 – section 3 to rated voltage 0,6/1 kV

Outer diameter of the cable or the strength of the flat cable in mm (D).

Type of installation	Ø to 10 mm	Ø more than 10 to 25 mm	Ø more than 25 mm
for hard wiring	4 x D	4 x D	4 x D
for molding	1 x D	2 x D	3 x D

(Not recommended by LÜTZE)

Flexible Cables	to 8 mm	more than 8 to 12 mm	more than 12 to 20 mm	more than 20 mm
for hard wiring	3 x D	3 x D	4 x D	4 x D
for free wiring	3 x D	4 x D	5 x D	5 x D
for insertion	3 x D	4 x D	5 x D	5 x D

D = outer diameter of the cable or the strength of the flat cable.

## Bend radii according to NFPA 79 specification (USA)

The bend radii must not fall short of the specified bend radii in the tables. For a shortfall a shortened life span is to be expected. Please note the recommended minimum radii of the manufacturer.

## Bend radii for the forced guiding of flexible cables according to NFPA 79 2015 edition chapter 13

Outer diameter of the cable or the size of the flat cable in mm (D).

Flexible cable	Ø up to 8 mm / 0.315 inches	Ø from 8 to 12 mm / 0.315 to 0.787 inches	Ø from 20 mm / 0.787 inches
Cable reel	6 x D	6 x D	8 x D
Guiding reel	6 x D	8 x D	8 x D
"Festoon" system	6 x D	6 x D	8 x D
all others	6 x D	6 x D	8 x D

## Bend radii in the cable tray according to NEC article 300.34 (USA)

The bending radius should not fall short of 8-times the diameter of an unshielded - and the 12-times the diameter of a shielded or lead-covered cable. That must be guaranteed after and during the installation.

The minimum bend radius for multiple-conductor cables or packed single-conductor cables with individual shielded conductor should be either 12-times the diameter of the largest shielded conductor, or 7-times of the overall diameter of the cable.

**Note:** All information are purely informative and following the mentioned standards. LÜTZE do not assume liability for the given information. Furthermore manufacturer information has to be considered.

# Torques for cable fittings

## Cable fittings with metric threads, EN 50262

Nominal size	recommended torque in Nm	
	Plastic	Metal
M 12 x 1.5	1.0	5
M 16 x 1.5	2.5	5
M 20 x 1.5	4.0	7.5
M 25 x 1.5	6.0	10
M 32 x 1.5	7.0	15
M 40 x 1.5	7.5	18
M 50 x 1.5	8.0	20
M 63 x 1.5	9.0	20

## Cable fittings with PG threads, DIN VDE 0619

Nominal size	recommended torque in Nm	
	Plastic	Metal
PG 7	2.5	6.25
PG 9	3.75	6.25
PG 11	3.75	6.25
PG 13.5	3.75	6.25
PG 16	5.0	7.5
PG 21	7.5	10.0
PG 29	7.5	10.0
PG 36	7.5	10.0
PG 42	7.5	10.0
PG 48	7.5	10.0

### Note:

The specified values are standard values for achieving the protection class IP 68, 5 bar.

The torque should be suitable to the material and wire application.



# Design of the protection class designation according to EN 60529

The protection of electrical equipment through corresponding enclosure is specified with code letters and code numbers. This protection class designation consists of the letters "IP" and two code numbers from 0 to 8. The first code number stands for the protection against contact and foreign substances, the second number specifies the degree of protection against water. The higher the respective code number is, the higher is the offered protection. The valid protection class for each product is specified in the technical data.

## For example the designation:

<b>IP 65</b>	<b>Code letter IP</b>	<b>IP</b>	
	<b>First code number</b>	<b>6</b>	<b>corresponds to: Protection against entrance of dust</b>
	<b>Second code number</b>	<b>5</b>	<b>corresponds to: Protection against sprayed water</b>

## For protection against contact and foreign substances

First code number	Protection scope designation	Explanation
0	No protection	No special protection of persons from accidental contact with standing or moving parts under voltage. No protection of the equipment against entry of solid foreign substances.
1	Protection against foreign substances > 50 mm	Protection against accidental contact of large area surfaces of standing and internally moving parts under voltage, e.g. with the hand, but no protection against intentional access to these parts. Protection against entry of solid foreign substances with a diameter larger than 50 mm.
2	Protection against foreign substances > 12 mm	Protection against contact by the fingers of standing or internally moving parts under voltage. Protection against entry of solid foreign substances with a diameter larger than 12 mm.
3	Protection against foreign substances > 2.5 mm	Protection against contact of standing or internally moving parts under voltage with tools, wires or similar of a thickness larger than 2.5 mm. Protection against entry of solid foreign substances with a diameter larger than 2.5 mm.
4	Protection against foreign substances > 1 mm	Protection against contact of standing or internally moving parts under voltage with tools, wires or similar of a thickness larger than 1 mm. Protection against entry of solid foreign substances with a diameter larger than 1 mm.
5	Protection against dust accumulation	Full protection against contact of standing or internally moving parts under voltage moving parts under voltage. Protection against dust accumulation. The entry of dust is not fully prevented but the dust may not enter in such quantities that the functioning is impaired.
6	Protection against dust accumulation	Full protection against contact of standing or internally moving parts under voltage moving parts under voltage. Protection against entry of dust.

## For water protection

Second code number	Protection scope designation	Explanation
0	No protection	No special protection
1	Protection from vertically falling dripping water	Water drops that fall vertically may not have any damaging effect.
2	Protection from dripping water falling at an angle	Water drops that fall at an arbitrary angle of up to 15° to vertical may not have any damaging effect.
3	Protection from sprayed water	Water that falls in an arbitrary angle up to 60° to vertical may not have a damaging effect.
4	Protection from splashed water	Water that is splashed from all directions against the equipment may not have a damaging effect.
5	Protection from water projected from a nozzle	Water projected from a nozzle that is aimed at the equipment from all directions may not have any damaging effect.
6	Protection against flooding	Water may not enter into the equipment in damaging amounts during temporary flooding (e.g. by heavy seas)
7	Protection against immersion	Water may not enter in damaging amounts if the equipment is immersed in water for the defined pressure and time conditions.
8	Protection against submersion	Water may not enter in damaging amounts if the equipment is submerged in water for the defined pressure and indefinite amount of time.

You can find the valid protection class for the respective product in the technical data.

# Short abbreviation key according to VDE and DIN

Symbol	Description
A-	outer cable
AB-	outer cable with lightning protection design
AJ-	outer cable with induction protection design
AiC-	conductor with copper wire braiding
b-	movement
(1B...)	one-layer steel band, . . . thickness of the steel band in mm
(2B...)	two-layer steel bands, . . . thickness of the steel band in mm
Bd	bundle cabling
c	protection sheathing from jute and bulk
C	shield from copper wire braid
(C)	shield from copper wire braid over an individual cabling element
Cu	copper wire
DM	Dieselhorst-Martin stranding
Dreier	triple-stranding
e	copper tinned wire
e	single-wire
E	protection sheathing from bulk with embedded plastic band
f	multi strand
ff	superfine strand
F	foil isolation
F	cable core with petroleum filling
F	flat design of installation cables
F	star quad with phantom utilization for
F	long distance communication cable of the railroad
(F...)	flat cable armor, . . . thickness in mm
G	rubber
2G	silicon rubber (SiR)
3G	isobutylene-isoprene rubber (IIR) or ethylene propylene rubber (EPR)
4G	ethylene vinyl acetate rubber (EVA)
5G	chloroprene rubber (CR)
6G	chlorosulfonated polyethylene (CSM)
7G	fluoride elastomer
8G	nitrile rubber (NBR)
G-	mine cable
GJ-	mine cable with induction protection design
J-	installation cable
JE-	installation cable for electronics industry
-J	cable with greenyellow ground conductor
-JZ	cable with greenyellow ground conductor and number printing
L-	cable
(L)	shield from plastic-coated aluminum band
(L)2Y	layered jacket
Lg	layer stranding
Li	conductor
m	jacket cable
M	lead jacket
Mz	lead jacket with hardening additive
-O	cable without greenyellow ground conductor
-OZ	cable without greenyellow ground conductor, with number printing
P	paper wire insulation
Pair	pair stranding
PiC	pair in copper wire braid
PiMF	pair in metal foil
PrI	test wire

Symbol	Description
Q	steel braid
RAGL-	compensation cable for thermocouples
RD-	RHENOMATIC-cable
RG-	coaxial cable according to MIL specification
re	round, single-wire
rm	round, multiple-wire
(R/R)	inner conductor copper wire not insulated, outer conductor copper wire braid
RS-	computer cable
S	conventional railway signal cable
S-	switching cable
St	star quad for phantom utilization
St I	star quad in telephone cables for large distances
St III	star quad in site cables
(St)	static shield
Staku	Staku steel-copper conductor
Stli	steel-copper braid
T	support for suspended cables
TF	carrier frequency
TiC	group of three in the copper wire braid
TiMF	group of three in metal foil
v	tinned
vs	silver-plated
vg	gold-plated
vn	nickel-plated
W	corrugated steel jacket
X	crosslinked polyvinylchloride (PVC)
2X	crosslinked polyethylene (PE)
10X	crosslinked polyvinylidene fluoride (PVDF)
11X	crosslinked polyurethane X-PUR
Y	polyvinyl chloride (PVC)
Yu	polyvinyl chloride (PVC) flame-retardant (STAN-NOFLAM)
Yv	polyvinyl chloride (PVC) reinforced jacket
Yw	polyvinyl chloride (PVC) heat resistant to 90 °C (105 °C with shortened service life)
2Y	polyethylene (PE)
2Yv	polyethylene (PE), reinforced Jacket
02Y	polyethylene foam (PE)
02YS	foam-Skin
3Y	polystyrene (PS)
4Y	polyamide (PA)
5Y	polytetrafluoroethylene (PTFE)
6Y	perfluoroethylene propylene (FEP), TEFLON
7Y	ethylene tetrafluoroethylene (ETFE)
8Y	polyimide (PI)
9Y	polypropylene (PP)
10Y	polyvinylidene fluoride (PVDF)
11Y	polyurethane (PUR)
12Y	polyethylene terephthalate (TPE, PETE)
(Z)	steel wire braid guaranteeing tensile strength

# Technical Terms

°C	Degree Celsius
(C)	Cable is shielded
Abrasion-resistant	The characteristic of a material to be resistant to abrasion
Conductor / Diameter	Eg.: 4G16 A cable with 4 conductor and respective conductor-diameter of 16 mm <sup>2</sup> . When the specification is used 4G16, is one of four conductors green/yellow. When the specification is used 416, is none of the four conductors green/yellow. (See G and x)
Low adhesion	For cables one refers to the so-called mechanical adhesion, that is the adhesion of faces (Anti-friction property)
Outer diameter	The nominal outer diameter of the cable
Outer layer	The position of a conductor, which is located directly under the jacket
AWG	American Wire Gauge
AWM	Appliance Wiring Material, "UL Subject 758" is an approval for components and applicable for cables installed at the factory
Mutual capacitance	Capacitance between the conductors for multi-conductor cables or between conductor and jacket
Bend radius	Specification how closely a cable is allowed to be bent. For cables, it is distinguished between fixed and flexible installed. It is given as multiplier of the outer diameter of the cable. (Eg. 10 x D ≈ 10 x 10,5 mm = 105 mm bent radius)
Bend cycle	Number of bends of the cable e.g. in cable tracks. Heavily depending on accurate installation. Must always be viewed in context of other parameter as e.g. bend radius and velocity.
Burning behavior	Indicates which fireproof standards of the cable are fulfilled
BUS	Binary Unit System for the digital data transmission
Cat	Category – Standard for the transmission speed of a network cable
CMG	Communication General – UL Listing or communication cable, requirements on the flame test are UL 1685 or FT 4 and there with higher quality as IEC 60332-3
CMX	Communication Residential – UL Listing for communication cable, requirements on flame test are UL VW-1 or FT 1
CSA	Canadian Standards Association
Cu	Copper
Cu-Number	Quantity of copper within the cable in kg/100m
D	Diameter of the cable
DESINA	DistributEd and Standardised INStAllation technology technology for machine tools and manufacturing systems
DIN	German institution of standardization
DRIVE-CLiQ®	Feedback/communication system by SIEMENS*
Dielectric strenght	The voltage at which the material loses its ability to insulate
Single-wire	Solid copper wire
E-Copper strand	Stranded electrolyte-copper wires
EMV	Electromagnetic compability
EN	European Standard
F	Farad – Unit of capacitance
Color-coded	The conductor insulations of the different conductors of a cable have defined colors
Finely stranded	Strand construction according to DIN VDE 0295 class 5, IEC 60228 class 5
Super finely stranded	Strand construction according to DIN VDE 0295 class 6, IEC 60228 class 6
Flame retardant	Hardly inflammable
Foil tape	The wrapping around the conductor with a foil for protection of the conductor.
Frequency converter	The device for changing a standard alternating voltage in a modifiable alternating voltage to vary the speed of an electric engine. The connection of a frequency converter to a motor should be made with a low capacitance cable
FT	Flame Test (Canada)
Fillers	Filling material which is used to achieve a circular cable
G	Protective conductor existing and included in the number of conductor
Braid shield	Copper shield made out of meshed copper wire
Halogen free	The cable does not emit the following halogenated substances : Fluorine, Chlorine, Iodine, Bromine und Astatine
HGI	High Glide Insulation – LÜTZE Standard for PP conductor insulation with very low friction coefficient resistances especially for high-flexible applications
Adhesion-free	The characteristic of a material not absorbing liquids
Hz	Herz
Impedance	Resistance at occurring alternating current
Inner jacket	See sub jacket
Insulation resistance	In general insulation resistance is the resistance which opposes a non-conductor e.g. the insulating jacket of a wire, to a more or less long-lasting flow of the current
J	Joule
Low-Capacitance	Here: The ability of a cable to transmit relatively current without loss
Capillary effect (Wicking)	The characteristic of into the cable incorporated fillings to absorb liquids and to involve in the cable
Nick-resistant	The characteristic of a material which describes the behavior during its deformation by intermittently stress
Copper strand - blank	No tin plating on faces of copper strand
Copper strand - tinned	Tin plating on surfaces of copper strand to avoid oxidation
Cabled in layers	Structure of conductors in a cable in layer
Strand	One conductor is made out of several copper wires
Magnetic Field	Electric current occurring field
Jacket	The outer protecting jacket of a cable, which protect the transmission conductor.
Minimum bend radius	Recommended value which should not be fallen short during bending of the cable. (is calculated from the diameter of the cable)

\* Registered trademark

# Technical Terms

NEC	National Electric Code (USA)
NEMA	National Electrical Manufacturers Association (USA)
Rated voltage	Electric voltage in stranded operation
NFPA	National Fire and Protection Agency (USA)
Optical coverage	Degree of coverage by the copper braid shield (how dense the shield is braided)
Ozone resistance	Ability of the material to withstand ozone radiation
Ozone resistance	There are 2 conductors twisted with each other in the cable
PE	Protective Earth – Protection conductor
PIMF	Pairs in Metal Foil – twisted pair cabled pairs of conductors are shielded separately
Polyethylen (PE)	Insulation material with very good electric characteristics, low water-absorption, high viscosity and excellent dielectric values
Polyolefin	Insulation material with good electric characteristics, good chemical resistance as well as high viscosity and ultimate elongation. Belongs to the Group of semi-crystalline thermoplastics
Polypropylen (PP)	Insulation material with good electric characteristics as well as high strength and stability. Belongs to the group of semi-crystalline thermoplastics
Polyurethan (PUR)	Thermoplastic Polyurethane – High-quality jacket-material for the usage in cable tracks and harsh environmental conditions
Polyvinylchlorid (PVC)	Popular jacket material for industrial control cable, allowed due to compounds with additives high flexibility and improved oil resistance
Test voltage	Represents the voltage with which the cable has been tested
RAL-Number	Numbered color system for definite identification of a color type
RoHS	Restriction of Hazardous Substances
Layer pitch optimized	The lay length of the cabled conductors will be optimized for the application shorter lay lengths for higher alternating bending
Loop resistance	In the transmission technique the loop resistance is the resistance of a at the end short-circuit pair of conductors am (Forward- and return cable e.g. of a BUS- cable)
Protective conductor	Grounding conductor
Self-extinguishing	The characteristic of a material to extinguish flames by itself (eg. PVC)
Servo	The name of a supply- and motor connection cable
Zero potential	High quality stranding technique for cabled conductor without mechanical back twist. Especially important for high-flexible cables for the use in cable tracks
StC	Double shielded (Static shield/foil+braid)
Star quad	Four conductors are cabled around a common axis
Control pair	Twisted conductor pairs for signal transmission in motor cables
Interfering signal	Cable- or fieldbound interferences
Radiation resistance	Resistance against radiation
Talcum	Talcum is used in powder as a release agent between the jacket and the conductor cable core. This allows the jacket to be removed easier later on
Temperature range	The recommended temperature range for the use of a cable
Thermoplastics	Thermoplastics can be transferred in a plastic state by heat supply
TI	Classification of characteristics of PVC Insulation material according to EN 50363
TM	Classification of characteristics of PVC jacket material according to EN 50363
Torsion	Here: The rotation of a cable around the longitudinal axis Specification for cable in °/m
TP	Twisted pair
TPE	Thermoplastic elastomere – High-quality material with good mechanical stress characteristics. Divided into various subgroups
U0/U	Rated voltage/Operating voltage
UL	Underwriters Laboratories
V	Volt
VDE	Association of Electrical, Electronic and Information Technologies
Rotproof	Increased resistance to rotting
Fleece wrap	A fleece wrapped around the conductors to protect the conductors and for better gliding characteristics.
VW-1	Flam test of UL (Vertical Wire Flame Test)
Wall thickness	The thickness of the jacket
Bend strength	The ability of a material not to break during permanent bending
Tear-resistant	The ability of a material to resist further cracking after a tear occurred
Characteristic impedance	Complex input resistance of infinite cable.
x	Ground conductor is not existing (like OZ, OB)
XLPE	Cross-linked polyethylene = XLPE
Tensile strength	The maximum tension (pulling)
Tension	Tension which is built up in the direction of the external load in the interior of an object
Sub jacket	Between conductor and shield introduced separation layer to protect the wires
Ω	Ohm

\* Registered trademark

# The price of copper

Cables and conductors are sold at DEL current daily prices for copper. The DEL is the listing for „Deutsches Elektrolytkupfer für Leitzwecke“ (German electrolyte copper for conducting purposes), i.e. 99.5 % pure copper. The DEL is specified in € per 100 kg.

You can normally find the DEL listing in the business section of the daily newspaper.

## The copper basis

A proportion of the copper price is contained in the list price of many cables and almost all wires already. It is also specified in € per 100 kg.

- 150.00 €/100 kg for the most popular wires
- 100.00 €/100 kg for telephone cables and wires
- 0.00 €/100 kg for underground cable (e.g. high-voltage current NY), thus price without metal.

Example: DEL 198.89 means:  
100 kg copper (Cu) costs € 198.89.

Additional purchasing costs of 1,0 % are added to the daily quote for cables and wires.

## The copper number (kg/100m)

The copper number is the copper weight of a cable or wire and is specified for every catalog article.

Example: Silflex N 3 G 1.5 mm<sup>2</sup>  
copper number according to catalog 4.32 kg/100 m  
The copper contained in 100 m of wire thus weighs 4.32 kg.

## Formula for calculation of the copper surcharge

$$\text{Copper number (kg/100 m)} \times \frac{(\text{DEL} + 1,0 \% \text{ purchasing costs}) - \text{copper basis}}{100} = \text{copper surcharge in €/100 m}$$

Example calculation: Silflex N 3 G 1.5 mm<sup>2</sup>  
DEL: 198.89 €/kg  
Cu-Basis: 150.00 €/kg  
Cu-Index: 4.32 kg/100 m

$$4.32 \text{ kg/100 m} \times \frac{(198.89 + 1,99) - 150.00}{100} = 2.20 \text{ €/100 m}$$

This sum would be for assumed DEL quote of 198.89 Euro the copper surcharge for 100 m Silflex N 3 G 1.5 mm<sup>2</sup>.

## Price including copper

The net price is calculated in the following way

$$\begin{array}{r} \text{Gross price} \\ - \text{Rebate (\%)} \\ \pm \text{Copper surcharge} \\ \hline = \text{Net price including copper} \end{array}$$

The copper surcharge is shown separately on our invoice.

# Conditions for the relinquishment of cable and wire spools

## Conditions for the relinquishment of cable and wire spools of the KABELTROMMEL GmbH & Co. KG in Köln (valid for the Federal Republic of Germany)

### § 1 Subject of the contract

Spools in the sense of the contract are standardized cable and wire spools of the sizes 05 to 28. Supporting material and spool casing are not subject matter of this contract.

### § 2 Conclusion of the contract

Between Kabeltrommel GmbH & Co. Kommanditgesellschaft, Köln (named as KTG in the following ), and the recipient of cables or wires (named as purchaser in the following) a contractual relationship to the following conditions results with the acquisition from the cable plant/wholesale of cables or wires on KTG-marked spools at the time of the receipt of spools at the purchaser or the receiving location designated by the purchaser.

### § 3 Rental fee

- (1) KTG calculates no rental fee for the renting of the spools of type 05 provided that these are returned to KTG within an appropriate time period. However, the respective security deposit\*) is calculated for the transferring of these spools abroad; the transfer is to be reported to the KTG.
- (2) For spools of the size 07 to 28, the following conditions are valid:
  - a) For a time period of 6 months, calculated starting with the delivery receipt of the respective supplier, no rental fee is calculated. If the spools are not returned within 6 months or numerically released in writing at the KTG, KTG imposes a spool rental fee. This amounts from the 7th month forward for every beginning month 15% of the security deposit\*) of the spools.
  - b) For spools that are not returned to the KTG by expiration of 12 months or are released in writing, the full security deposit value is calculated as sales price. The KTG is prepared to take back spools that are sent back after the previously mentioned time limit, however, within 3 years. Provided that these spools are in a proper state, the KTG reimburses 25% of the security deposit.
  - c) The calculation occurs in each case after return/release of the spool, at the latest, however, after expiration of the rental period of 12 months. The sales tax is added in the respective legal amount to the time of the issuing of the invoice.

### § 4 Risk assumption and liability of the purchaser

The purchaser bears the risk and is liable for all damages to spools from the point in time of the beginning of the contract up to the acceptance of the spools through the KTG according to § 6, as far as they are not purchased according to § 3, (2) b.

### § 5 Guarantee and liability of the KTG

- (1) The liability of the KTG – equal for whatever legal ground – is restricted to the respective replacement wires in the framework of the coverage of its liability insurance, that is concluded in the usual scope with measured adequate insured sums for property damage and bodily injury.
- (2) A further liability – equal for whatever legal ground– is explicitly excluded.

### § 6 Return transport of spools

- (1) The purchaser must notify the KTG about all released spools for action of the return transport continuously and without delay in writing. This is arranged for through the KTG within an appropriate period of time.
- (2) The freight charges for the return transport are incurred by the KTG; for the loading or as the case may be for incidental loading costs at the place of dispatch, the purchaser/lessor is responsible.
- (3) All costs that accrue through return transport not according to instructions are to be carried by the purchaser.
- (4) As far as the purchaser has brought spools abroad, the purchaser has to arrange for the return transport at the purchaser's own cost.

### § 7 Payments

Invoices of the KTG are payable due net no later than 14 days after receipt. For delay of payment, we calculate – besides incidental dunning costs – interest on late payments in the amount of at least 3 % over the prime rate of the German Federal Bank or respectively the higher of arising costs to us from the intermediate financing of the owed amount.

### § 8 Jurisdiction– miscellaneous

- (1) Jurisdiction for all disputes resulting from this contractual relationship is Cologne, Germany.
- (2) The KTG is also entitled to file a suit at the site of the respective purchaser.
- (3) Changes and additions to this contract must be in written form; this also applies for an amendment to this clause.

\*) The security deposits comply with the respective valid conditions of the KABELTROMMEL GmbH & Co. KG

KABELTROMMEL GmbH & Co. KG  
Schanzenstr. 30  
51063 Cologne  
Tel.: 02 21/67 88-0  
Fax: 02 21/67 88-205  
www.kabeltrommel.de  
info@kabeltrommel.de

Validity area: Federal Republic of Germany

# Certificates



## CERTIFICATE

This is to certify that

**Friedrich Lütze GmbH**  
Bruckwiesenstrasse 17-19  
71384 Weinstadt

with the organizational units/sites as listed in the annex

has implemented and maintains a **Quality Management System**.

Scope:  
Development, production and distribution of electrical and electronic components and solutions for the automation technology

Through an audit, documented in a report, it was verified that the management system fulfills the requirements of the following standard:

**ISO 9001 : 2008**

Certificate registration no. 001737 QM08	
Date of certification 2013-07-05	
Valid until 2016-07-04	

**DQS GmbH**  
*G. Blechschmidt*  
Gitta Blechschmidt  
Managing Director

 Accredited Body: DQS GmbH, August-Schnoor-Strasse 21, 60433 Frankfurt am Main



## CERTIFICATE

This is to certify that

**Friedrich Lütze GmbH**  
Bruckwiesenstrasse 17-19  
71384 Weinstadt

has implemented and maintains an **Environmental Management System**.

Scope:  
Development, production and distribution of electrical and electronic components and solutions for the automation technology

Through an audit, documented in a report, it was verified that the management system fulfills the requirements of the following standard:

**ISO 14001 : 2004 + Cor 1 : 2009**

Certificate registration no. 001737 UM	
Date of certification 2013-08-03	
Valid until 2016-08-02	

**DQS GmbH**  
*G. Blechschmidt*  
Gitta Blechschmidt  
Managing Director

 Accredited Body: DQS GmbH, August-Schnoor-Strasse 21, 60433 Frankfurt am Main



## C E R T I F I C A T E

awarded to

**Friedrich Lütze GmbH**  
Bruckwiesenstrasse 17-19  
71384 Weinstadt  
Germany

**DQS GmbH**

confirms, as an IRIS approved certification body, that the Management System of the above organization has been assessed and found to be in accordance with the

**International Railway Industry Standard (IRIS)**  
**Revision 02, May 2009**

for the activity of Design and development & Manufacturing  
for the scopes of certification 9 (On board vehicle control)  
Electrical and electronic components and solutions for the automation technology

Certificate valid from: 21/05/2013      Certificate valid until: 20/05/2016 \*

*G. Blechschmidt*

Current date: 08/07/2013  
Certificate-Register-No.: 001737 IRIS

\* Providing that the subsequent surveillance audits are successful before the anniversary of this validity date.  
This document has been produced by the Audit-Tool V. 4.0.2.10  
Issued to DQS, on 06/07/2013  
©2013 ULAPF. All rights reserved.

# Article number index

Part-No.	Page	Part-No.	Page	Part-No.	Page	Part-No.	Page	Part-No.	Page	Part-No.	Page
100001	1.3	100456	1.4	101388	5.3	108126	2.3	108674	2.7	108776	2.8
100002	1.3	100458	1.4	101389	5.3	108128	2.3	108675	2.7	108800	1.12
100012	1.3	100464	1.4	101390	5.3	108147	2.4	108676	2.7	108801	1.12
100013	1.3	100465	1.4	101423	2.4	108149	2.4	108677	2.7	108802	1.12
100024	1.3	100468	1.4	101424	1.11	108154	2.4	108678	2.7	108803	1.12
100025	1.3	100469	1.4	101494	5.5	108208	1.4	108679	2.7	108934	2.8
100026	1.3	100552	2.4	101495	5.5	108600	2.6	108680	2.7	108935	2.8
100027	1.3	100707	1.11	101496	5.5	108601	2.6	108682	2.7	108936	2.8
100050	1.3	100736	1.4	101501	5.5	108602	2.6	108683	2.7	108937	2.8
100051	1.3	100737	1.4	101502	5.5	108603	2.6	108684	2.7	108938	2.8
100052	1.3	100761	1.11	101503	5.5	108604	2.6	108685	2.7	109323	1.6
100053	1.3	100765	1.11	101504	5.5	108605	2.6	108686	2.7	109700	1.6
100079	1.3	100766	1.11	101505	5.5	108606	2.6	108687	2.7	109701	1.6
100080	1.3	100767	1.11	101506	5.5	108607	2.6	108688	2.7	109702	1.6
100081	1.3	100768	1.11	101507	5.5	108608	2.6	108689	2.7	109703	1.6
100105	1.3	100769	1.11	101508	5.5	108609	2.6	108690	2.7	109704	1.6
100106	1.3	100777	1.11	101509	5.5	108610	2.6	108691	2.7	109705	1.6
100107	1.3	100778	1.11	104207	4.9	108612	2.6	108692	2.7	109707	1.6
100118	1.3	100782	1.11	104214	4.4	108613	2.6	108694	2.7	109708	1.6
100119	1.3	100784	1.11	104216	4.3	108614	2.6	108695	2.7	109711	1.6
100123	1.3	100787	1.11	104217	4.3	108615	2.6	108696	2.7	109712	1.6
100124	1.3	100788	1.11	104258	4.10	108616	2.6	108697	2.7	109713	1.6
100215	1.4	100789	1.11	104259	4.10	108617	2.6	108698	2.7	109714	1.6
100327	2.3	100790	1.11	104265	4.6	108618	2.6	108699	2.7	109715	1.6
100338	2.3	100791	1.11	104267	4.4	108619	2.6	108700	2.7	109716	1.6
100358	1.4	100792	1.11	104275	4.6	108620	2.6	108701	2.7	109718	1.6
100363	1.4	100793	1.11	104277	4.4	108621	2.6	108702	2.7	109719	1.6
100364	1.4	100794	1.11	104278	4.4	108622	2.6	108703	2.7	109720	1.6
100365	1.4	100795	1.11	104279	4.12	108624	2.6	108704	2.7	109721	1.6
100366	1.4	100796	1.11	104282	4.11	108625	2.6	108706	2.7	109722	1.6
100369	1.4	100797	1.11	104287	4.6	108626	2.6	108707	2.7	109723	1.6
100370	1.4	100807	1.11	104288	4.11	108627	2.6	108708	2.7	109724	1.6
100373	1.4	100808	1.11	104289	4.12	108628	2.6	108709	2.7	109725	1.6
100384	1.4	100856	1.11	104293	4.5	108629	2.6	108710	2.7	109727	1.6
100385	1.4	100871	1.4	104301	4.13	108630	2.6	108711	2.7	109728	1.6
100386	1.4	100893	1.11	104302	4.14	108631	2.6	108712	2.7	109729	1.6
100387	1.4	100900	1.11	104303	4.14	108632	2.6	108713	2.7	109730	1.6
100389	1.4	100918	2.3	104307	4.13	108633	2.6	108714	2.7	109731	1.6
100391	1.4	100920	2.3	104310	5.17	108634	2.6	108715	2.7	109732	1.6
100392	1.4	100922	2.3	104313	5.7	108636	2.6	108716	2.7	109733	1.6
100395	1.4	100948	2.3	104331	4.13	108637	2.6	108718	2.7	109734	1.6
100398	1.4	100951	2.3	104335	4.13	108638	2.6	108719	2.7	109735	1.6
100405	1.4	100964	2.3	104336	4.13	108639	2.6	108720	2.7	109737	1.6
100406	1.4	100983	1.3	104337	4.14	108640	2.6	108721	2.7	109738	1.6
100407	1.4	100987	1.11	104338	4.13	108641	2.6	108722	2.7	109740	1.6
100408	1.4	100990	1.4	104341	5.7	108642	2.6	108723	2.7	109741	1.6
100410	1.4	100998	1.11	104344	4.5	108643	2.6	108724	2.7	109742	1.6
100411	1.4	101048	1.11	104347	4.14	108644	2.6	108725	2.7	109743	1.6
100412	1.4	101049	1.11	104378	4.5	108645	2.6	108726	2.7	109744	1.6
100413	1.4	101052	2.3	104379	4.14	108646	2.6	108727	2.7	109749	1.6
100415	1.4	101180	5.3	104386	4.7	108648	2.6	108728	2.7	109750	1.6
100416	1.4	101181	5.3	104387	4.7	108649	2.6	108751	2.8	109751	1.6
100417	1.4	101182	5.3	104388	4.7	108650	2.6	108753	2.8	109752	1.6
100419	1.4	101190	5.3	104389	4.7	108651	2.6	108754	2.8	109753	1.6
100429	1.4	101191	5.3	104390	4.8	108652	2.6	108755	2.8	109754	1.6
100430	1.4	101192	5.3	104391	4.8	108653	2.6	108756	2.8	109800	1.7
100431	1.4	101193	5.3	104396	4.14	108654	2.6	108761	2.8	109801	1.7
100432	1.4	101280	2.4	104397	4.13	108655	2.6	108763	2.8	109802	1.7
100433	1.4	101281	2.4	108000	1.12	108656	2.6	108764	2.8	109803	1.7
100437	1.4	101288	1.12	108001	1.12	108657	2.6	108765	2.8	109804	1.7
100440	1.4	101321	2.5	108002	1.12	108658	2.6	108766	2.8	109805	1.7
100443	1.4	101351	1.11	108003	1.12	108670	2.7	108771	2.8	109807	1.7
100453	1.4	101385	5.3	108049	1.11	108671	2.7	108773	2.8	109808	1.7
100454	1.4	101386	5.3	108055	1.11	108672	2.7	108774	2.8	109812	1.7
100455	1.4	101387	5.3	108125	2.3	108673	2.7	108775	2.8	109813	1.7



# Article number index

Part-No.	Page	Part-No.	Page	Part-No.	Page	Part-No.	Page	Part-No.	Page	Part-No.	Page
109814	1.7	110179	1.8	110645	2.5	111291	5.16	111545	5.9	111778	5.23
109815	1.7	110180	1.8	110647	2.5	111292	5.16	111548	5.9	111779	5.23
109816	1.7	110181	1.8	110650	2.4	111293	5.16	111560	5.13	111780	5.18
109818	1.7	110182	1.8	110658	2.4	111294	5.16	111561	5.13	111781	5.18
109819	1.7	110183	1.8	110659	2.5	111295	5.16	111562	5.13	111879	5.10
109821	1.7	110184	1.8	110660	2.5	111296	5.16	111563	5.13	111997	5.12
109822	1.7	110185	1.8	110665	2.5	111303	1.12	111564	5.13	111998	5.11
109823	1.7	110186	1.8	110701	1.12	111304	1.12	111598	5.14	113300	1.17
109824	1.7	110188	1.8	110710	2.4	111305	1.12	111599	5.14	113301	1.17
109825	1.7	110189	1.8	110717	2.4	111306	1.12	111600	5.14	113302	1.17
109827	1.7	110191	1.8	110719	2.3	111327	2.4	111601	5.14	113303	1.17
109828	1.7	110192	1.8	110720	2.4	111329	1.12	111602	5.14	113304	1.17
109831	1.7	110193	1.8	110722	2.4	111337	5.15	111603	5.14	113305	1.17
109832	1.7	110194	1.8	110736	2.4	111370	5.9	111604	5.14	113306	1.17
109833	1.7	110195	1.8	110742	2.4	111371	5.9	111605	5.14	113307	1.17
109834	1.7	110196	1.8	110743	2.4	111372	5.9	111651	1.9	113308	1.17
109835	1.7	110197	1.8	110787	2.4	111373	5.9	111652	1.9	113309	1.17
109837	1.7	110248	2.5	110790	2.4	111374	5.9	111653	1.9	113310	1.17
109838	1.7	110249	2.3	110872	3.3	111375	5.9	111654	1.9	113311	1.17
109840	1.7	110371	2.4	110874	3.3	111376	5.9	111656	1.9	113312	1.17
109841	1.7	110372	1.8	110927	2.3	111377	5.9	111657	1.9	113313	1.17
109842	1.7	110374	2.4	110929	2.4	111378	5.9	111658	1.9	113314	1.17
109843	1.7	110415	2.3	110940	5.18	111388	5.11	111659	1.9	113315	1.17
109844	1.7	110418	1.8	110941	5.18	111412	5.17	111660	1.9	113316	1.17
109859	1.6	110424	1.8	110945	2.3	111416	5.23	111661	1.9	113317	1.17
109860	1.6	110437	1.8	110947	1.12	111417	5.23	111662	1.9	113318	1.18
109861	1.6	110443	1.8	110954	1.12	111418	5.22	111663	1.9	113319	1.18
109862	1.7	110446	1.12	110988	2.3	111420	5.10	111664	1.9	113320	1.18
109863	1.7	110450	1.8	110991	1.8	111421	5.10	111665	1.9	113321	1.18
109864	1.6	110457	1.8	110992	1.8	111422	5.10	111666	1.9	113322	1.18
109865	1.6	110459	1.8	110993	2.4	111423	5.10	111667	1.9	113323	1.18
110000	2.3	110471	2.4	111001	1.12	111424	5.10	111668	1.9	113324	1.17
110001	2.3	110475	2.4	111016	1.8	111425	5.10	111669	1.9	113325	1.17
110002	2.3	110478	2.4	111045	1.11	111426	5.10	111670	1.9	113328	1.17
110003	2.3	110489	1.12	111082	2.4	111427	5.10	111671	1.9	113331	1.18
110004	2.3	110499	1.12	111086	2.4	111428	5.10	111672	1.9	113332	1.18
110005	2.3	110506	1.8	111102	1.8	111429	5.9	111673	1.9	113339	1.18
110006	2.3	110514	2.4	111126	5.15	111430	5.9	111674	1.9	113340	1.18
110008	2.3	110526	1.8	111127	5.15	111437	5.23	111675	1.9	113341	1.18
110009	2.3	110563	1.12	111128	5.15	111438	5.23	111676	1.9	113342	1.18
110010	2.3	110564	1.12	111129	5.15	111439	5.12	111677	1.9	113344	1.18
110011	2.3	110567	1.12	111130	5.15	111452	5.17	111678	1.9	113345	1.17
110070	2.3	110600	2.5	111131	5.15	111453	5.17	111679	1.9	113346	1.18
110071	2.3	110601	2.5	111132	5.15	111454	5.17	111680	1.9	113347	1.17
110072	2.3	110602	2.5	111133	5.15	111456	5.17	111681	1.9	113360	1.18
110073	2.3	110604	2.5	111136	5.15	111457	5.17	111682	1.9	113361	1.18
110074	2.3	110606	2.5	111197	5.15	111458	5.17	111684	1.9	113362	1.18
110075	2.3	110607	2.5	111206	2.4	111459	5.17	111685	1.9	113363	1.18
110076	2.3	110608	1.12	111215	1.12	111460	5.10	111686	1.9	113364	1.18
110078	2.3	110609	2.5	111241	5.15	111461	5.10	111687	1.9	113365	1.18
110079	2.3	110618	2.5	111243	5.15	111462	5.10	111688	1.9	113366	1.18
110080	2.3	110619	2.5	111245	1.12	111463	5.10	111690	1.9	113400	1.15
110081	2.3	110620	2.5	111246	1.12	111464	5.10	111707	1.8	113401	1.15
110089	2.3	110622	2.5	111247	1.12	111465	5.10	111719	5.11	113402	1.15
110122	2.3	110625	2.5	111248	1.12	111466	5.10	111762	5.11	113403	1.15
110123	2.3	110626	2.5	111270	5.11	111467	5.10	111763	5.12	113404	1.15
110125	2.3	110629	2.5	111271	5.11	111468	5.10	111764	5.12	113405	1.15
110127	2.3	110633	2.5	111276	5.11	111479	5.23	111765	5.12	113406	1.16
110129	2.3	110634	2.5	111277	5.11	111488	5.21	111769	5.19	113407	1.16
110131	2.3	110635	2.5	111278	5.11	111489	5.21	111771	5.19	113408	1.16
110135	2.3	110637	2.5	111279	5.11	111490	5.23	111772	5.20	113409	1.16
110168	1.8	110641	2.5	111285	5.15	111491	5.23	111773	5.20	113410	1.16
110169	1.8	110642	2.5	111288	5.16	111492	5.23	111774	5.22	113411	1.16
110177	1.8	110643	2.5	111289	5.16	111495	5.18	111776	5.22	113412	1.16
110178	1.8	110644	1.8	111290	5.16	111536	5.12	111777	5.22	113415	1.16

# Article number index

Part-No.	Page	Part-No.	Page	Part-No.	Page	Part-No.	Page	Part-No.	Page	Part-No.	Page
113416	1.16	116191	1.5	117096	2.11	118042	1.12	192730.0100	6.36	193246.1000	6.12
113417	1.16	116234	1.5	117097	2.11	118194	1.12	192740.0100	6.36	193247.1000	6.12
113422	1.15	116235	1.5	117098	2.11	118195	2.5	192750.0100	6.36	193248.1000	6.12
113425	1.15	116238	1.5	117099	2.11	118239	1.12	193000.1000	6.13	193249.1000	6.12
113426	1.16	116250	1.5	117100	2.11	118244	2.5	193001.1000	6.13	193250.1000	6.12
113428	1.15	116297	1.5	117101	2.11	118251	2.5	193020.1000	6.11	193251.1000	6.12
113430	1.17	116401	5.6	117102	2.11	118252	2.5	193034.1000	6.13	193252.1000	6.12
113431	1.15	116402	5.6	117103	2.11	118297	2.5	193040.1000	6.11	193253.1000	6.12
113432	1.15	116403	5.6	117104	2.11	118320	2.4	193041.1000	6.11	193254.1000	6.12
113433	1.15	116404	5.6	117105	2.11	118322	2.5	193042.1000	6.11	193255.1000	6.12
113435	1.15	116405	5.6	117106	2.11	118383	1.11	193043.1000	6.11	193256.1000	6.12
113437	1.15	116406	5.6	117107	2.11	118384	1.11	193044.1000	6.11	193257.1000	6.12
113438	1.15	116407	5.6	117108	2.11	118389	1.4	193045.1000	6.11	193258.1000	6.12
113439	1.15	116408	5.6	117109	2.11	118393	1.11	193046.1000	6.11	193259.1000	6.12
113441	1.15	116415	5.6	117110	2.11	118406	2.4	193047.1000	6.13	193260.1000	6.12
113442	1.15	116416	5.6	117111	2.11	118407	2.4	193048.1000	6.11	193261.1000	6.12
113443	1.15	116417	5.6	117112	2.11	118408	2.4	193049.1000	6.11	193262.1000	6.12
113444	1.15	116418	5.6	117113	2.11	118409	2.4	193050.1000	6.11	193263.1000	6.12
113445	1.15	116419	5.6	117114	2.11	118410	2.4	193051.1000	6.11	193264.1000	6.12
113446	1.15	116420	5.6	117115	2.11	118411	2.4	193052.1000	6.11	193265.1000	6.12
113447	1.15	116421	5.6	117116	2.11	118412	2.4	193053.1000	6.11	193266.1000	6.12
113448	1.15	116501	5.4	117170	2.12	118413	2.4	193054.1000	6.11	193267.1000	6.12
113479	1.16	116502	5.4	117171	2.12	118421	2.4	193055.1000	6.11	193268.1000	6.12
113483	1.16	116503	5.4	117172	2.12	118427	2.4	193056.1000	6.11	193269.1000	6.12
113484	1.15	116504	5.4	117173	2.12	118430	2.4	193057.1000	6.11	193270.1000	6.12
113485	1.16	116505	5.4	117174	2.12	118438	2.4	193058.1000	6.11	193271.1000	6.12
113570	1.16	116506	5.4	117175	2.12	118439	2.4	193059.1000	6.11	193301.1000	6.8
113571	1.16	116507	5.4	117176	2.12	118466	2.4	193060.1000	6.11	193303.1000	6.8
113572	1.16	116508	5.4	117177	2.12	118467	2.4	193061.1000	6.11	193306.1000	6.6
113573	1.16	117027	2.10	117180	2.12	118471	2.4	193062.1000	6.11	193307.1000	6.8
113574	1.16	117028	2.10	117181	2.12	118476	2.4	193063.1000	6.11	193308.1000	6.8
113575	1.16	117029	2.10	117182	2.12	118481	2.4	193064.1000	6.11	193309.1000	6.8
113576	1.16	117030	2.10	117183	2.12	118991	2.4	193065.1000	6.11	193311.1000	6.8
113577	1.16	117031	2.10	117184	2.12	190003	6.37	193066.1000	6.11	193337.1000	6.7
116100	1.5	117032	2.10	117185	2.12	190004	6.37	193067.1000	6.11	193350.1000	6.9
116102	1.5	117033	2.10	117186	2.12	190005	6.37	193068.1000	6.11	193352.1000	6.6
116103	1.5	117034	2.10	117187	2.12	190006	6.37	193069.1000	6.11	193353.1000	6.6
116104	1.5	117035	2.10	117190	2.12	190007	6.37	193071.1000	6.11	193355.1000	6.8
116105	1.5	117036	2.10	117191	2.12	190008	6.37	193072.1000	6.11	193356.1000	6.6
116106	1.5	117037	2.10	117192	2.12	190009	6.37	193073.1000	6.11	193357.1000	6.6
116107	1.5	117038	2.10	117193	2.12	190010	6.37	193074.1000	6.11	193358.1000	6.7
116110	1.5	117039	2.10	117194	2.12	190012	6.37	193080.1000	6.11	193360.1000	6.8
116112	1.5	117040	2.10	117195	2.12	190013	6.37	193140.1000	6.13	193361.1000	6.8
116113	1.5	117041	2.10	117196	2.12	190014	6.37	193141.1000	6.13	193362.1000	6.6
116114	1.5	117042	2.10	117199	2.12	190015	6.37	193142.1000	6.13	193364.1000	6.10
116115	1.5	117043	2.10	117201	2.12	190016	6.37	193143.1000	6.13	193366.1000	6.10
116116	1.5	117044	2.10	117202	2.12	190017	6.37	193144.1000	6.13	193369.1000	6.6
116117	1.5	117045	2.10	117203	2.12	190018	6.37	193145.1000	6.13	193370.1000	6.10
116121	1.5	117046	2.10	117204	2.12	190019	6.37	193146.1000	6.13	193371.1000	6.10
116123	1.5	117047	2.10	117205	2.12	190559	6.37	193147.1000	6.13	193373.1000	6.10
116124	1.5	117048	2.10	117240	3.3	190560	6.37	193148.1000	6.13	193374.1000	6.10
116125	1.5	117049	2.10	117241	3.3	190570	6.37	193149.1000	6.13	193375.1000	6.10
116126	1.5	117050	2.10	117242	3.3	192000.0100	6.35	193150.1000	6.13	193376.1000	6.10
116127	1.5	117051	2.10	117243	3.3	192010.0100	6.35	193151.1000	6.13	193620.1000	6.13
116128	1.5	117052	2.10	117244	3.3	192022.0100	6.35	193152.1000	6.13	193700.1000	6.16
116132	1.5	117053	2.10	117245	3.3	192030.0100	6.35	193153.1000	6.13	193702.1000	6.16
116133	1.5	117054	2.10	117246	3.3	192050.0100	6.35	193154.1000	6.13	193706.1000	6.18
116134	1.5	117055	2.10	117250	3.4	192100.0100	6.35	193164.1000	6.13	193707.1000	6.18
116135	1.5	117056	2.10	117251	3.4	192112.0100	6.35	193165.1000	6.13	193708.1000	6.18
116139	1.5	117090	2.11	117252	3.4	192130.0100	6.35	193240.1000	6.12	193709.1000	6.18
116150	1.5	117091	2.11	117253	3.4	192201.0100	6.35	193241.1000	6.12	193710.1000	6.18
116151	1.5	117092	2.11	117254	3.4	192300.0100	6.35	193242.1000	6.12	193711.1000	6.18
116152	1.5	117093	2.11	117255	3.4	192700.0100	6.36	193243.1000	6.12	193712.1000	6.16
116153	1.5	117094	2.11	117303	2.12	192710.0100	6.36	193244.1000	6.12	193713.1000	6.16
116174	1.5	117095	2.11	118039	1.12	192720.0100	6.36	193245.1000	6.12	193714.1000	6.18

# Article number index

Part-No.	Page	Part-No.	Page	Part-No.	Page	Part-No.	Page	Part-No.	Page	Part-No.	Page
193715.1000	6.18	193912.1000	6.15	198054.1000	6.20	198186.1000	6.24	198318.1000	6.26	198830.1000	6.33
193716.1000	6.18	193913.1000	6.15	198055.1000	6.27	198187.1000	6.31	198319.1000	6.26	198840.1000	6.29
193717.1000	6.18	193920.1000	6.15	198058.1000	6.23	198198.1000	6.27	198320.1000	6.21	198845.1000	6.27
193718.1000	6.18	193921.1000	6.15	198059.1000	6.20	198200.1000	6.33	198321.1000	6.19	198850.1000	6.33
193728.1000	6.16	193956.1000	6.6	198060.1000	6.27	198204.1000	6.30	198322.1000	6.19	198870.1000	6.29
193729.1000	6.16	193957.1000	6.8	198062.1000	6.23	198205.1000	6.19	198323.1000	6.19	198871.1000	6.22
193730.1000	6.16	193958.1000	6.9	198063.1000	6.20	198210.1000	6.33	198325.1000	6.21	198880.1000	6.29
193736.1000	6.16	193959.1000	6.7	198064.1000	6.23	198214.1000	6.26	198326.1000	6.26	198881.1000	6.22
193737.1000	6.16	193960.1000	6.6	198066.1000	6.20	198216.1000	6.30	198327.1000	6.26	198890.1000	6.32
193738.1000	6.16	193961.1000	6.6	198067.1000	6.23	198217.1000	6.30	198328.1000	6.26	198900.1000	6.32
193739.1000	6.16	193962.1000	6.6	198068.1000	6.20	198220.1000	6.33	198329.1000	6.26	198910.1000	6.32
193740.1000	6.16	193966.1000	6.6	198071.1000	6.20	198240.1000	6.33	198330.1000	6.26	198950.1000	6.27
193741.1000	6.16	193973.1000	6.9	198073.1000	6.20	198245.1000	6.21	198331.1000	6.26	198980.1000	6.27
193744.1000	6.16	193977.1000	6.9	198075.1000	6.29	198247.1000	6.28	198332.1000	6.26	198985.1000	6.30
193745.1000	6.16	193978.1000	6.9	198076.1000	6.22	198248.1000	6.31	198333.1000	6.28	198990.1000	6.31
193746.1000	6.16	193979.1000	6.9	198078.1000	6.20	198249.1000	6.31	198334.1000	6.28	198991.1000	6.24
193764.1000	6.17	193983.1000	6.8	198080.1000	6.29	198250.1000	6.33	198335.1000	6.28	198995.1000	6.30
193765.1000	6.17	193985.1000	6.8	198081.1000	6.22	198252.1000	6.31	198336.1000	6.28	330068.0010	10.10
193766.1000	6.17	193989.1000	6.8	198083.1000	6.20	198254.1000	6.31	198337.1000	6.28	330071.0010	10.8
193767.1000	6.17	193990.1000	6.6	198085.1000	6.29	198259.1000	6.29	198338.1000	6.28	330072.0010	10.8
193768.1000	6.17	193991.1000	6.8	198086.1000	6.22	198260.1000	6.33	198339.1000	6.28	330073.0010	10.8
193769.1000	6.17	193994.1000	6.8	198088.1000	6.20	198262.1000	6.29	198340.1000	6.21	330074.0010	10.10
193770.1000	6.17	193996.1000	6.8	198090.1000	6.29	198263.1000	6.29	198341.1000	6.21	330088.0010	10.9
193771.1000	6.17	197455	6.34	198091.1000	6.22	198264.1000	6.22	198342.1000	6.21	330089.0100	10.7
193772.1000	6.17	197456	6.34	198093.1000	6.20	198267.1000	6.29	198343.1000	6.21	331000.0010	10.13
193773.1000	6.17	197457	6.34	198095.1000	6.29	198273.1000	6.20	198344.1000	6.21	331001.0010	10.13
193774.1000	6.17	197458	6.34	198096.1000	6.22	198275.1000	6.29	198345.1000	6.21	331002.0010	10.13
193775.1000	6.17	197459	6.34	198098.1000	6.19	198276.1000	6.29	198346.1000	6.21	331003.0010	10.13
193776.1000	6.17	197460	6.34	198100.1000	6.29	198277.1000	6.29	198349.1000	6.29	331004.0010	10.13
193777.1000	6.17	197473	6.34	198101.1000	6.22	198278.1000	6.29	198353.1000	6.20	346109.0010	10.12
193778.1000	6.17	197474	6.34	198103.1000	6.19	198279.1000	6.29	198360.1000	6.27	346110.0010	10.12
193779.1000	6.17	197475	6.34	198104.1000	6.19	198280.1000	6.33	198380.1000	6.27	346111.0010	10.12
193780.1000	6.17	197476	6.34	198105.1000	6.33	198283.1000	6.27	198400.1000	6.27	346112.0010	10.11
193781.1000	6.17	197477	6.34	198106.1000	6.19	198284.1000	6.27	198410.1000	6.27	346113.0010	10.11
193782.1000	6.17	197478	6.34	198107.1000	6.19	198285.1000	6.27	198430.1000	6.27	346114.0010	10.12
193783.1000	6.17	197500	6.34	198108.1000	6.19	198286.1000	6.27	198440.1000	6.27	346116.0010	10.11
193784.1000	6.17	197501	6.34	198109.1000	6.19	198287.1000	6.22	198450.1000	6.27	346123.0010	10.11
193785.1000	6.17	197502	6.34	198110.1000	6.33	198288.1000	6.22	198460.1000	6.29	346812	10.3
193786.1000	6.17	197503	6.34	198115.1000	6.29	198289.1000	6.22	198461.1000	6.22	346813	10.5
193787.1000	6.17	197504	6.34	198116.1000	6.22	198292.1000	6.20	198480.1000	6.29	346814.0010	10.6
193788.1000	6.17	197505	6.34	198120.1000	6.33	198293.1000	6.20	198481.1000	6.22	346860.0002	10.4
193789.1000	6.17	198005.1000	6.31	198123.1000	6.19	198294.1000	6.20	198500.1000	6.29	410003	7.22
193790.1000	6.17	198006.1000	6.24	198124.1000	6.19	198295.1000	6.33	198501.1000	6.22	410006	7.22
193791.1000	6.17	198010.1000	6.31	198126.1000	6.19	198296.1000	6.22	198530.1000	6.29	410010	7.22
193792.1000	6.17	198011.1000	6.24	198128.1000	6.19	198297.1000	6.22	198531.1000	6.22	410015	7.22
193793.1000	6.17	198015.1000	6.30	198129.1000	6.19	198298.1000	6.22	198560.1000	6.29	410020	7.22
193794.1000	6.18	198020.1000	6.30	198130.1000	6.33	198299.1000	6.20	198561.1000	6.22	410050	7.22
193804.1000	6.17	198025.1000	6.31	198132.1000	6.19	198300.1000	6.26	198570.1000	6.29	411003	7.23
193805.1000	6.17	198026.1000	6.24	198133.1000	6.19	198301.1000	6.26	198571.1000	6.22	411006	7.23
193806.1000	6.17	198030.1000	6.30	198136.1000	6.19	198302.1000	6.26	198580.1000	6.29	411010	7.23
193807.1000	6.17	198035.1000	6.27	198139.1000	6.19	198303.1000	6.26	198581.1000	6.22	411015	7.23
193808.1000	6.17	198036.1000	6.25	198140.1000	6.33	198304.1000	6.26	198628.1000	6.33	411020	7.23
193809.1000	6.17	198037.1000	6.25	198143.1000	6.23	198305.1000	6.26	198700.1000	6.33	411050	7.23
193811.1000	6.17	198038.1000	6.25	198144.1000	6.23	198306.1000	6.26	198730.1000	6.31	415020	7.17
193813.1000	6.17	198040.1000	6.27	198146.1000	6.22	198307.1000	6.26	198731.1000	6.24	415050	7.17
193814.1000	6.17	198042.1000	6.20	198150.1000	6.33	198308.1000	6.26	198735.1000	6.31	415100	7.17
193900.1000	6.14	198044.1000	6.23	198160.1000	6.33	198309.1000	6.20	198740.1000	6.33	416020	7.19
193901.1000	6.14	198045.1000	6.27	198170.1000	6.33	198310.1000	6.28	198765.1000	6.30	416050	7.19
193902.1000	6.14	198046.1000	6.20	198176.1000	6.21	198311.1000	6.28	198790.1000	6.31	416100	7.19
193903.1000	6.14	198048.1000	6.20	198177.1000	6.21	198312.1000	6.28	198791.1000	6.24	418003	7.40
193904.1000	6.14	198049.1000	6.23	198178.1000	6.21	198313.1000	6.28	198800.1000	6.31	418006	7.40
193905.1000	6.14	198050.1000	6.27	198179.1000	6.21	198314.1000	6.28	198801.1000	6.24	418010	7.40
193906.1000	6.14	198051.1000	6.20	198182.1000	6.21	198315.1000	6.28	198803.1000	6.27	418015	7.40
193910.1000	6.15	198052.1000	6.20	198183.1000	6.24	198316.1000	6.28	198810.1000	6.27	418020	7.40
193911.1000	6.15	198053.1000	6.23	198184.1000	6.24	198317.1000	6.26	198820.1000	6.30	418050	7.40

# Article number index

Part-No.	Page	Part-No.	Page	Part-No.	Page	Part-No.	Page	Part-No.	Page	Part-No.	Page
420003	7.39	440050	7.41	458705	7.27	475503	7.12	490038	7.55	496930	7.9
420006	7.39	441003	7.47	458710	7.27	475506	7.12	490050	7.56	496950	7.9
420010	7.39	441006	7.47	458802	7.31	475510	7.12	490051	7.56	499988	7.72
420015	7.39	441010	7.47	458805	7.31	475515	7.12	490052	7.56	499989	7.71
420020	7.39	441015	7.47	458810	7.31	475520	7.12	490053	7.56	499993	7.72
420050	7.39	441020	7.47	458902	7.35	475550	7.12	490054	7.56	499994	7.71
422003	7.37	441050	7.47	458905	7.35	475702	7.4	490057	7.48	499995	7.72
422006	7.37	442003	7.39	458910	7.35	475705	7.4	490059	7.48	499996	7.72
422010	7.37	442006	7.39	459203	7.42	475710	7.4	490060	7.65	600090	9.21
422015	7.37	442010	7.39	459206	7.42	475802	7.5	490061	7.65	600091	9.21
422020	7.37	442015	7.39	459210	7.42	475805	7.5	490062	7.65	600092	9.21
422050	7.37	442020	7.39	459215	7.42	475810	7.5	490063	7.65	600093	9.21
424003	7.41	442050	7.39	459220	7.42	475903	7.6	490064	7.66	600094	9.21
424006	7.41	443020	7.33	459250	7.42	475905	7.6	490065	7.66	600095	9.21
424010	7.41	443050	7.33	462020	7.32	475910	7.6	490066	7.66	600096	9.21
424015	7.41	443100	7.33	462050	7.32	475915	7.6	490067	7.66	600097	9.21
424020	7.41	445003	7.45	462100	7.32	475920	7.6	490068	7.66	600120	9.23
424050	7.41	445006	7.45	464020	7.32	475930	7.6	490069	7.66	600170	9.15
428003	7.38	445010	7.45	464050	7.32	475950	7.6	490070	7.50	600171	9.15
428006	7.38	445015	7.45	464100	7.32	476020	7.21	490071	7.51	600172	9.15
428010	7.38	445020	7.45	465020	7.28	476050	7.21	490072	7.58	600173	9.15
428015	7.38	445050	7.45	465050	7.28	476100	7.21	490073	7.58	600174	9.15
428020	7.38	447020	7.15	465100	7.28	477020	7.29	490074	7.59	600175	9.15
428050	7.38	447050	7.15	466020	7.28	477050	7.29	490077	7.56	600176	9.15
429003	7.38	447100	7.15	466050	7.28	477100	7.29	490089	7.57	600177	9.15
429006	7.38	456102	7.26	466100	7.28	478020	7.29	490095	7.61	600201	9.21
429010	7.38	456105	7.26	467003	7.40	478050	7.29	490105	7.70	600202	9.21
429015	7.38	456110	7.26	467006	7.40	478100	7.29	490106	7.70	600203	9.21
429020	7.38	456202	7.27	467010	7.40	479020	7.33	490107	7.70	600204	9.21
429050	7.38	456205	7.27	467015	7.40	479050	7.33	490108	7.70	600205	9.21
431003	7.43	456210	7.27	467020	7.40	479100	7.33	490112	7.68	600206	9.21
431006	7.43	456402	7.30	467050	7.40	481020	7.17	490113.0030	7.67	600207	9.21
431010	7.43	456405	7.30	468020	7.36	481050	7.17	490113.0060	7.67	600208	9.21
431015	7.43	456410	7.30	468050	7.36	481100	7.17	490113.0080	7.67	600220	9.19
431020	7.43	456502	7.31	468100	7.36	482020	7.25	490113.0150	7.67	600221	9.19
431050	7.43	456505	7.31	469020	7.36	482050	7.25	490113.0200	7.67	600222	9.19
435003	7.44	456510	7.31	469050	7.36	482100	7.25	490113.0300	7.67	600223	9.19
435006	7.44	456702	7.34	469100	7.36	486020	7.15	490113.0500	7.67	600224	9.19
435010	7.44	456705	7.34	471020	7.24	486050	7.15	490123	7.49	600225	9.19
435015	7.44	456710	7.34	471050	7.24	486100	7.15	490124	7.49	600226	9.19
435020	7.44	456802	7.35	471100	7.24	487003	7.22	490125	7.49	600227	9.19
435050	7.44	456805	7.35	472020	7.24	487006	7.22	490126	7.49	600228	9.19
436003	7.46	456810	7.35	472050	7.24	487010	7.22	490128	7.62	600229	9.19
436006	7.46	457503	7.42	472100	7.24	487015	7.22	490129	7.62	600230	9.19
436010	7.46	457506	7.42	473020	7.25	487020	7.22	490138	7.62	600231	9.19
436015	7.46	457510	7.42	473050	7.25	487050	7.22	490150	7.60	600232	9.19
436020	7.46	457515	7.42	473100	7.25	488003	7.23	490151	7.63	600280	9.20
436050	7.46	457520	7.42	474020	7.19	488006	7.23	490152	7.63	600281	9.20
438003	7.47	457550	7.42	474050	7.19	488010	7.23	490153	7.63	600282	9.20
438006	7.47	458202	7.16	474100	7.19	488015	7.23	491075	7.69	600283	9.20
438010	7.47	458205	7.16	475300.0200	7.13	488020	7.23	492075	7.69	600284	9.20
438015	7.47	458210	7.16	475300.0500	7.13	488050	7.23	496702	7.7	600285	9.20
438020	7.47	458302	7.18	475300.1000	7.13	490011	7.51	496705	7.7	600286	9.20
438050	7.47	458305	7.18	475302	7.10	490012	7.51	496710	7.7	600320	9.5
439003	7.46	458310	7.18	475305	7.10	490014	7.53	496802	7.8	600321	9.5
439006	7.46	458402	7.18	475310	7.10	490015	7.53	496805	7.8	600347	9.5
439010	7.46	458405	7.18	475400.0030	7.14	490017	7.50	496810	7.8	600361	9.17
439015	7.46	458410	7.18	475400.0060	7.14	490018	7.50	496903	7.9	600362	9.17
439020	7.46	458502	7.20	475400.0100	7.14	490020	7.52	496905	7.9	600363	9.17
439050	7.46	458505	7.20	475400.0150	7.14	490021	7.52	496906	7.9	600364	9.17
440003	7.41	458510	7.20	475400.0200	7.14	490026	7.55	496907	7.9	600365	9.17
440006	7.41	458602	7.20	475400.0500	7.14	490028	7.54	496908	7.9	600366	9.17
440010	7.41	458605	7.20	475402	7.11	490029	7.54	496910	7.9	600367	9.17
440015	7.41	458610	7.20	475405	7.11	490035	7.48	496915	7.9	600368	9.17
440020	7.41	458702	7.27	475410	7.11	490037	7.48	496920	7.9	600370	9.16

# Article number index

Part-No.	Page	Part-No.	Page	Part-No.	Page	Part-No.	Page	Part-No.	Page	Part-No.	Page
600371	9.16	600506	9.20	600629	9.22	600760	9.13	606003	9.3	700190	8.46
600372	9.16	600507	9.20	600630	9.22	600761	9.13	606004	9.3	700191	8.46
600373	9.16	600508	9.20	600631	9.22	600762	9.13	606005	9.3	700192	8.46
600374	9.16	600510	9.20	600632	9.22	600763	9.13	606006	9.3	700217	8.45
600375	9.16	600511	9.20	600633	9.22	600780	9.14	606007	9.3	700321	8.7
600376	9.16	600512	9.20	600634	9.22	600781	9.14	606038	9.3	700323	8.7
600377	9.16	600513	9.20	600635	9.22	600782	9.14	606040	9.3	700324	8.7
600391	9.9	600520	9.15	600636	9.22	600783	9.14	606052	9.3	700374	8.42
600392	9.9	600521	9.15	600637	9.22	600790	9.6	606053	9.3	700379	8.42
600393	9.9	600522	9.15	600638	9.22	600791	9.6	606150	9.4	700413	8.4
600394	9.9	600523	9.15	600639	9.22	600792	9.6	606151	9.4	700414	8.4
600395	9.9	600524	9.15	600640	9.22	600830	9.10	606152	9.4	700435	8.5
600396	9.9	600525	9.15	600641	9.22	600831	9.10	606153	9.4	700440	8.4
600398	9.9	600526	9.15	600642	9.22	600832	9.10	606154	9.4	700445	8.4
600400	9.19	600527	9.15	600643	9.22	600833	9.10	606155	9.4	700446	8.4
600401	9.19	600528	9.15	600644	9.22	600834	9.10	606156	9.4	700463	8.6
600402	9.19	600529	9.15	600645	9.22	600835	9.10	606157	9.4	700464	8.6
600403	9.19	600530	9.18	600646	9.22	600836	9.10	606158	9.4	700466	8.5
600404	9.19	600531	9.18	600647	9.22	600837	9.10	606159	9.4	700475	8.5
600405	9.19	600532	9.18	600648	9.22	600838	9.10	606160	9.4	700476	8.5
600406	9.19	600533	9.18	600649	9.22	600839	9.10	606200	9.4	700490	8.43
600407	9.19	600534	9.18	600651	9.22	600840	9.6	606201	9.4	700491	8.43
600408	9.19	600535	9.18	600652	9.22	600841	9.6	606202	9.4	700492	8.43
600409	9.19	600536	9.18	600653	9.22	600842	9.6	606203	9.4	700493	8.43
600410	9.19	600537	9.18	600654	9.22	600843	9.6	606204	9.4	700527	8.47
600411	9.19	600538	9.18	600655	9.22	600844	9.6	606205	9.4	700529	8.47
600412	9.19	600539	9.18	600656	9.22	600845	9.6	606206	9.4	700568	8.5
600413	9.19	600541	9.22	600660	9.7	600846	9.6	606207	9.4	700577	8.5
600414	9.19	600542	9.22	600661	9.7	600847	9.6	606208	9.4	700857	8.37
600415	9.19	600543	9.22	600662	9.7	600850	9.9	606209	9.4	700861	8.37
600416	9.19	600544	9.22	600663	9.7	600851	9.9	606250	9.4	700863	8.37
600417	9.19	600545	9.22	600664	9.7	600852	9.9	606251	9.4	700867	8.37
600420	9.17	600546	9.22	600665	9.7	600853	9.9	606252	9.4	700881	8.37
600421	9.17	600550	9.11	600666	9.7	600854	9.9	606253	9.4	700897	8.37
600422	9.17	600551	9.11	600667	9.7	600855	9.9	606254	9.4	700910	8.37
600423	9.17	600552	9.11	600668	9.7	600856	9.9	606255	9.4	700950	8.8
600424	9.17	600553	9.11	600669	9.7	600857	9.9	606256	9.4	700951	8.8
600425	9.17	600554	9.11	600680	9.6	600860	9.7	606257	9.4	700952	8.8
600426	9.17	600555	9.11	600681	9.6	600861	9.7	606258	9.4	700953	8.9
600427	9.17	600556	9.11	600682	9.6	600862	9.7	606259	9.4	700954	8.9
600428	9.17	600557	9.11	600683	9.6	600863	9.7	606260	9.4	700955	8.9
600429	9.17	600558	9.11	600684	9.6	600864	9.7	680100	9.25	700956	8.10
600430	9.10	600559	9.11	600690	9.8	600865	9.7	680101	9.25	700957	8.10
600431	9.10	600560	9.11	600691	9.8	600866	9.7	680102	9.25	700958	8.10
600432	9.10	600561	9.11	600692	9.8	600867	9.7	680105	9.25	700959	8.8
600433	9.10	600562	9.11	600693	9.8	600868	9.7	680106	9.25	700960	8.8
600434	9.10	600563	9.11	600698	9.9	600869	9.7	680107	9.25	700962	8.10
600435	9.10	600564	9.11	600701	9.13	600870	9.12	680108	9.25	701533	8.40
600436	9.10	600565	9.11	600702	9.13	600871	9.12	680418	9.26	701534	8.40
600437	9.10	600566	9.11	600703	9.13	600872	9.12	680419	9.26	701583	8.6
600438	9.10	600567	9.11	600704	9.13	600873	9.12	680420	9.28	705141	8.38
600439	9.10	600568	9.11	600705	9.14	600874	9.12	680424	9.26	705341	8.38
600460	9.18	600569	9.11	600706	9.14	600875	9.12	680428	9.26	705502	8.28
600461	9.18	600570	9.11	600707	9.14	600876	9.12	680429	9.26	705503	8.31
600462	9.18	600590	9.21	600708	9.14	600877	9.12	680571	9.24	705505	8.28
600463	9.18	600591	9.21	600710	9.13	601490	9.12	680572	9.24	705507	8.28
600464	9.18	600592	9.21	600711	9.13	601491	9.12	680573	9.24	705509	8.30
600465	9.18	600593	9.21	600712	9.13	601492	9.12	680574	9.24	705605	8.34
600466	9.18	600594	9.21	600713	9.13	601493	9.12	680576	9.24	705610	8.35
600467	9.18	600595	9.21	600714	9.13	601494	9.12	681032	9.27	705705	8.34
600500	9.20	600596	9.21	600715	9.13	601495	9.12	681033	9.27	705709	8.35
600501	9.20	600597	9.21	600716	9.13	601496	9.12	681034	9.27	705800	8.27
600502	9.20	600626	9.22	600717	9.13	601497	9.12	681310	9.26	705801	8.27
600503	9.20	600627	9.22	600718	9.13	606001	9.3	681316	9.27	705802	8.33
600504	9.20	600628	9.22	600719	9.13	606002	9.3	681318	9.27	705803	8.33

# Article number index

Part-No.	Page	Part-No.	Page	Part-No.	Page	Part-No.	Page	Part-No.	Page	Part-No.	Page
705804	8.36	709482	8.13	709773	8.19						
705805	8.36	709483	8.13	709774	8.19						
705810	8.27	709484	8.13	709775	8.19						
705811	8.33	709485	8.13	709782	8.21						
705812	8.33	709486	8.13	709789	8.21						
705813	8.36	709487	8.13	709790	8.22						
705814	8.36	709519	8.18	709791	8.22						
705830	8.27	709526	8.19	709792	8.22						
705831	8.33	709527	8.19	709794	8.22						
705832	8.33	709600	8.18	772104	7.64						
705833	8.36	709601	8.18	A							
705834	8.36	709605	8.18	A1381204	1.13						
706115	8.41	709606	8.18	A1381207	1.13						
706120	8.39	709607	8.18	A1381404	1.13						
706121	8.39	709608	8.18	A1381405	1.13						
706161	8.3	709615	8.23	A1381407	1.13						
706167	8.44	709616	8.23	A1381603	1.13						
706509	8.30	709617	8.23	A1381604	1.13						
707403	8.28	709625	8.23	A1381605	1.13						
707409	8.30	709626	8.23	A1381607	1.13						
707507	8.29	709627	8.23	A1381612	1.13						
707508	8.29	709635	8.24	A1381618	1.13						
707512	8.31	709636	8.24	A1381625	1.13						
707514	8.32	709637	8.24	A1381803	1.13						
709427.0250	8.17	709645	8.24	A1381804	1.13						
709427.0500	8.17	709646	8.24	A1381805	1.13						
709427.0750	8.17	709647	8.24	A1381807	1.13						
709427.1000	8.17	709653	8.25	A1381812	1.13						
709427.1500	8.17	709654	8.25	A1381818	1.13						
709427.2000	8.17	709659	8.25	A1381825	1.13						
709428.0250	8.16	709666	8.26	A1381834	1.13						
709428.0500	8.16	709667	8.26	A1381841	1.13						
709428.0750	8.16	709668	8.26	A1382003	1.13						
709428.1000	8.16	709673	8.18	A1382004	1.13						
709428.1500	8.16	709674	8.18	A1382005	1.13						
709428.2000	8.16	709675	8.18	A1382007	1.13						
709441.0250	8.12	709700	8.19	A1382012	1.13						
709441.0500	8.12	709701	8.19	A1382018	1.13						
709441.0750	8.12	709705	8.19	A1382025	1.13						
709441.1000	8.12	709706	8.19	A1391204	1.14						
709441.1500	8.12	709707	8.19	A1391207	1.14						
709441.2000	8.12	709708	8.19	A1391404	1.14						
709442.0250	8.11	709709.0250	8.20	A1391405	1.14						
709442.0500	8.11	709709.0500	8.20	A1391407	1.14						
709442.0750	8.11	709709.1000	8.20	A1391603	1.14						
709442.1000	8.11	709715	8.23	A1391604	1.14						
709442.1500	8.11	709716	8.23	A1391605	1.14						
709442.2000	8.11	709717	8.23	A1391607	1.14						
709443.0250	8.14	709725	8.23	A1391612	1.14						
709443.0500	8.14	709726	8.23	A1391618	1.14						
709443.0750	8.14	709727	8.23	A1391625	1.14						
709443.1000	8.14	709735	8.24	A1391803	1.14						
709443.1500	8.14	709736	8.24	A1391804	1.14						
709443.2000	8.14	709737	8.24	A1391805	1.14						
709459	8.15	709745	8.24	A1391807	1.14						
709460	8.15	709746	8.24	A1391812	1.14						
709461	8.15	709747	8.24	A1391818	1.14						
709462	8.15	709753	8.25	A1391825	1.14						
709469	8.15	709754	8.25	A1392003	1.14						
709472	8.13	709759	8.25	A1392004	1.14						
709473	8.13	709766	8.26	A1392005	1.14						
709474	8.13	709767	8.26	A1392007	1.14						
709475	8.13	709768	8.26	A1392012	1.14						
709476	8.13	709771	8.21	A1392018	1.14						
709477	8.13	709772	8.21	A1392025	1.14						

# Notes

---





# Notes

---



**Copyright**

Protected trademarks and trade names are not always labelled as such in this publication. This does not mean they are free names as defined in the trademark and brand mark law. Publication does not imply that the descriptions or pictures used are free from rights of third parties. The information is published without regard to possible patent protection. Trade names are used without any guarantee that they can be used freely. In putting together text, pictures and data, we proceeded with the greatest care. Despite this, the possibility of errors cannot be completely excluded. We therefore reject any legal responsibility or liability. We are, of course, grateful for any recommendations for improvement or information useful for making corrections or establishing the truth. But the author does not assume any responsibility for the content of these documents.



**RoHS**

**Germany**  
 Friedrich Lütze GmbH  
 Postfach 12 24 (PLZ 71366)  
 Bruckwiesenstrasse 17-19  
 D-71384 Weinstadt  
 Tel.: +49 7151 6053-0  
 Fax: +49 7151 6053-277(-288)  
 info@luetze.de



- Cables**
- Cable assemblies**
- Cable fittings**
- Cable conduits**
- LSC wiring system**
- Module- and Interface Technology**
- Industrial Ethernet**
- Suppression technology**
- Industrial Power Supplies**
- Intelligent current control**
- Railway technology**

**United Kingdom**  
 LÜTZE Ltd.  
 Unit 3 Sandy Hill Park  
 Sandy Way, Amington  
 Tamworth, Staffs, B77 4DU  
 Tel.: +44 1827 31333-0  
 Fax: +44 1827 31333-2  
 sales.gb@luetze.co.uk

**USA**  
 LUTZE INC.  
 13330 South Ridge Drive  
 Charlotte, NC 28273  
 Tel.: +1 704 504-0222  
 Fax: +1 704 504-0223  
 info@lutze.com

**Austria**  
 LÜTZE Elektrotechnische  
 Erzeugnisse Ges.m.b.H.  
 office@luetze.at

**Switzerland**  
 LÜTZE AG  
 info@luetze.ch

**France**  
 LUTZE SAS  
 lutze@lutze.fr

**Spain**  
 LUTZE, S.L.  
 info@lutze.es

**China**  
 Luetze Trading (Shanghai) Co.Ltd.  
 info@luetze.cn